

System Overview

These instructions review how to install TruGroove surface fixtures. TruGroove 4ft, 6ft and 8ft modules can be installed as individual standalone units, or they can be joined together to create continuous runs.

IMPORTANT: Read all instructions before beginning installation. All ceiling brackets must be secured to ceiling structure (studs or cross-braces). Power feed connections for TruGroove surface modules can be made through a recessed 2"X4" utility box (by others) or with a surface mounted junction box/exposed conduit (by others).

TruGroove Endcap Kit(s)

- TG D/I endcap (x1)
- Ceiling bracket (x1)
- Shims (x3)
- 1/4-20 hex lock nut (x1)
- 1/4" ID washer (x1)
- #8-32 x 5/16" hex screw (x2)

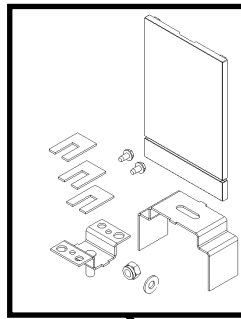

Ceiling brackets (supplied)

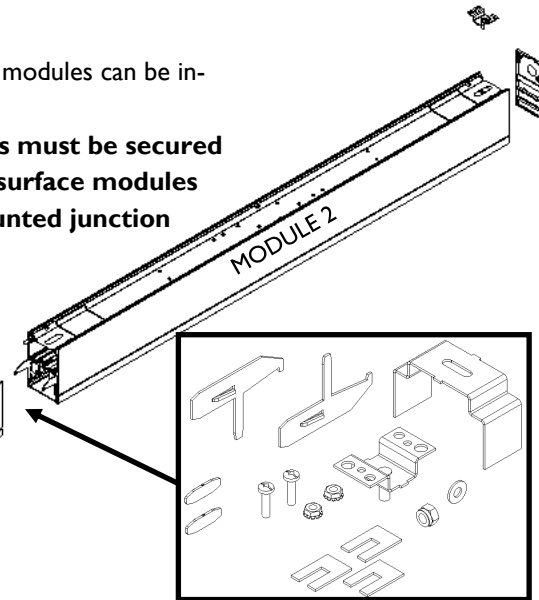
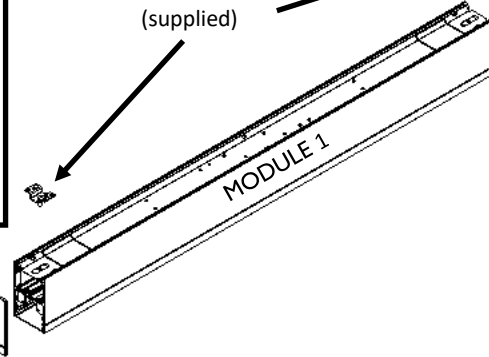

TruGroove Joint Kit(s)

- Joiner aligner (x2)
- Joiner biscuits (x2)
- Ceiling mount bracket (x1)
- Shims (x3)
- 1/4-20 hex lock nut (x1)
- 1/4" ID washer (x1)
- #10-32 x 3/4" (x2)
- #10-32 hex lock nut (x2)

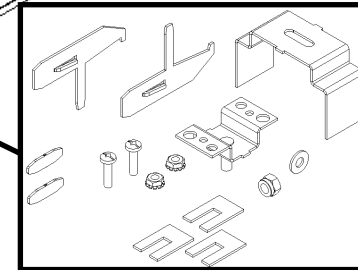

Module Lengths

TruGroove surface fixtures come in 4ft, 6ft, and 8ft modules. Overall module lengths are shown below. Add 0.2" for each endcap for accurate run length.

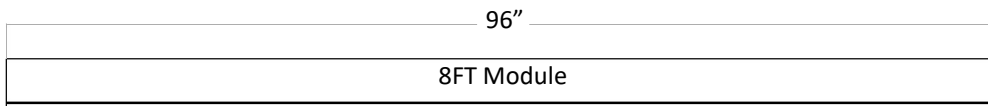
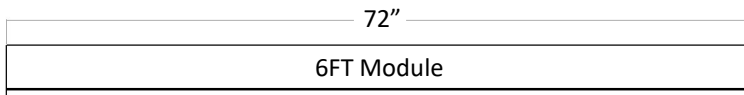
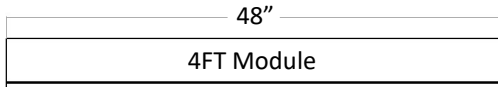

Tools Required:

- 7/16" Nut Driver
- 3/8" Nut Driver
- 1/4" Nut Driver
- Phillips Screwdriver
- Flat ScrewDriver
- 7/16" Open Wrench

Mount Spacing

TruGroove surface fixture modules are designed to attach to supplied ceiling brackets. The table below provides mounting bracket spacing for each module.

Module Length	Mounting Dimensions
4FT	45-5/8"
6FT	69-5/8"
8FT	93-5/8"

! ATTENTION: Install in accordance with national and local building and electrical codes.

1 Arrange boxed fixture on floor in specified mounting location, remove fixtures from boxes.

2a Lens Removal

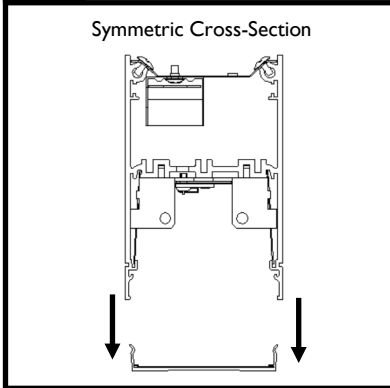

Remove lens from fixture and set aside until fixture installation is complete. Use cotton gloves to handle lenses and keep in a clean environment. **Note:** Do not mix symmetric fixture lenses with asymmetric fixture types as they are different.

2b Lens Removal

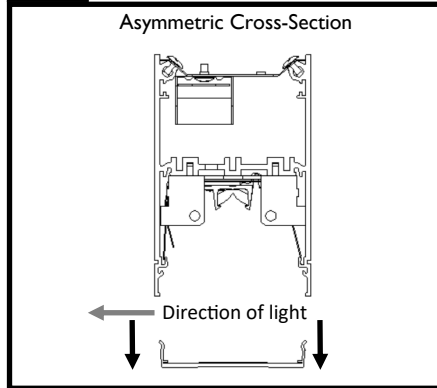

3 Ceiling Bracket Installation

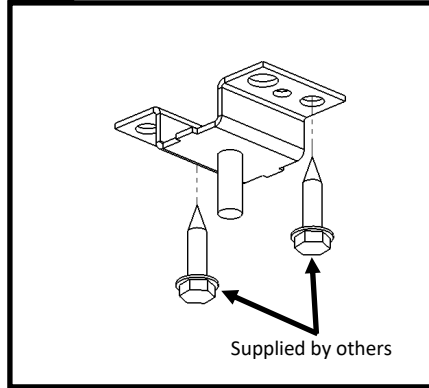

Determine location of ceiling brackets. Use table on page 1 for exact dimensions. Center and install ceiling brackets to structure (studs or cross-braces) using appropriate hardware (by others)

4a Recessed Utility Box

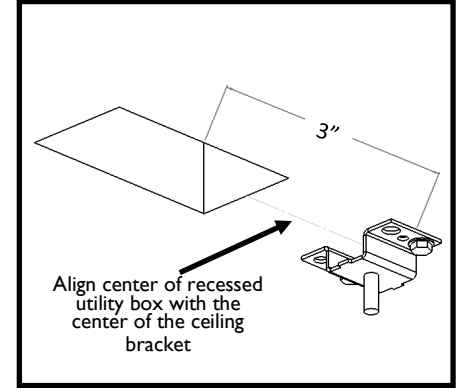

For a recessed 2"X4" utility box, align and center with ceiling brackets, and install with long edge parallel with fixture module length. Ensure utility box is positioned 3" away from ceiling bracket.

4b Surface Junction Box

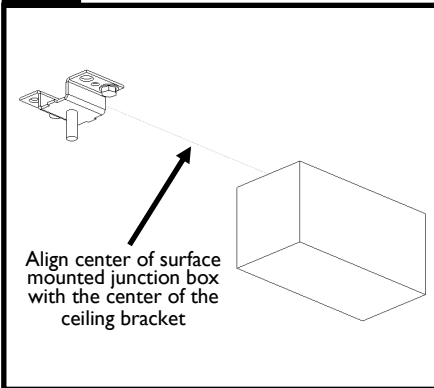

For a surface mounted junction box, install junction box as required. For a cleaner install and better alignment with installed fixture modules, center junction box and conduit exit with center line of ceiling brackets.

5 Surface Mount Bracket Installation

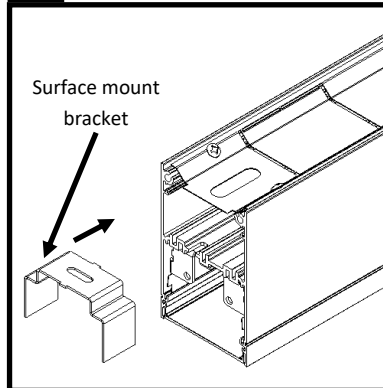

Insert surface mount brackets approximately 2 inches inside module 1. Ensure bracket engages and slides inside upper fixture module channel. Ensure slot in fixture reflector aligns with slot in surface mount bracket.

6 Recessed Power Feed Location

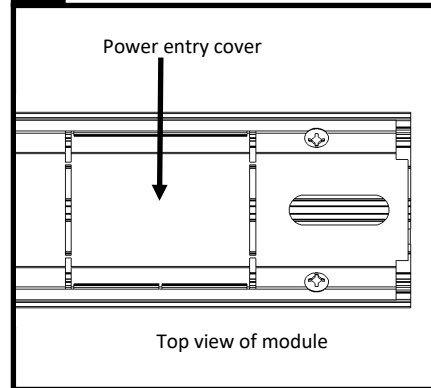

Determine fixture power feed method and location. For a recessed utility box installation, break off power cover tabs using a flat screwdriver at required end only.

7 Fixture Installation

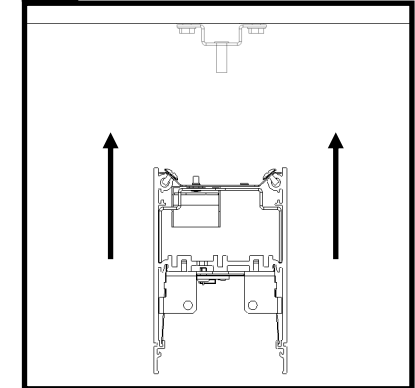

Raise module 1 towards ceiling, supporting both ends a few inches below ceiling level.

! ATTENTION: Install in accordance with national and local building and electrical codes.

8 Recessed Power Feed Connection

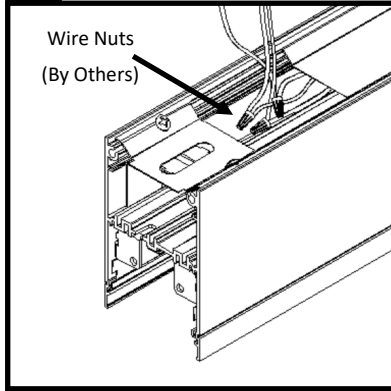

While supporting the module in the air complete power entry wiring connections. Ensure all connections are secure and all wires are neatly tucked inside fixture wiring cavity.

9a Surface Power Feed Preparation

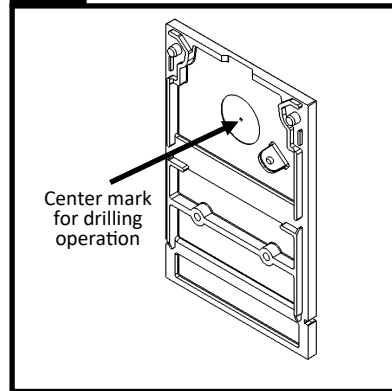

For surface junction box installation, power feed to fixture module is done through the endcap. Use masking tape on all outside surfaces, turn over and place on a wood block. Align with center mark as shown and drill a 7/8" diameter hole.

9b Surface Power Feed Connection

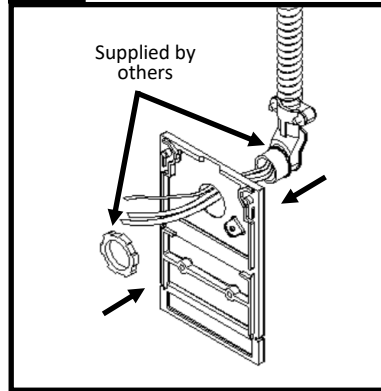

Prepare power feed by installing the conduit and the connectors (by others) to the drilled endcap. Refer to steps 13 and 14 for power connections and endcap installation.

10 Fixture Installation

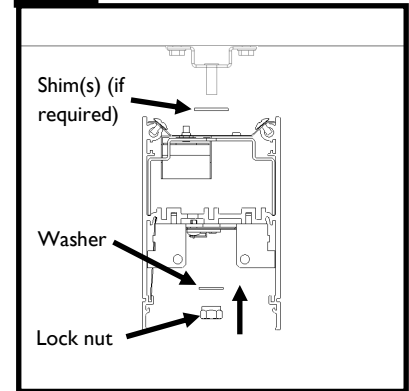

Raise module 1 to ceiling, align ceiling bracket 1/4"-20 stud with housing slot and surface bracket slot.

11 Fixture Installation

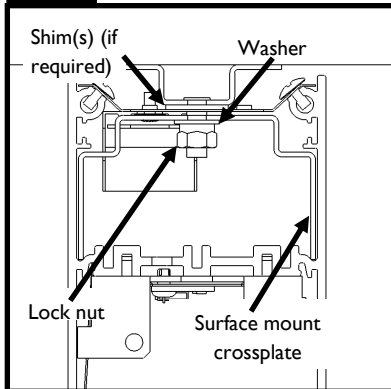

From below fixture secure 1/4" ID washer and 1/4"-20 hex nut to ceiling bracket 1/4"-20 stud. If ceiling is not level, install supplied shims as required then tighten 1/4"-20 hex nuts.

12 Fixture Joining

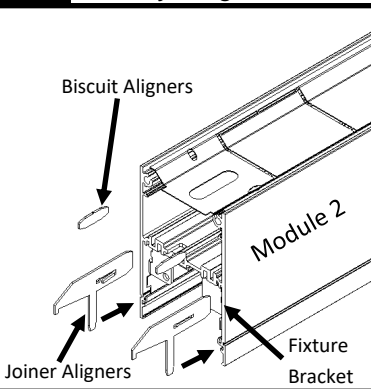

With module 2 on the ground, tap biscuit aligners inside top screw chase. Ensure biscuit aligners are inserted more than half way inside fixture housing. Insert joiner aligners inside lower screw chase as shown. Ensure orientation is correct for locking tab to engage and lock inside fixture bracket.

13 Fixture Joining

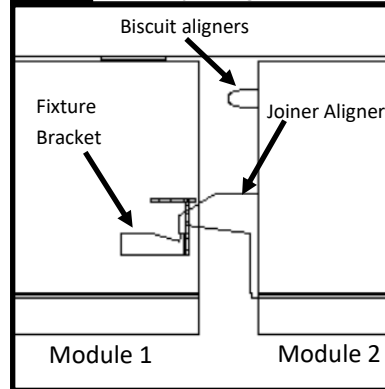

Bring modules together and engage joiner aligners in module 2 on fixture bracket in module 1. **Note: Do not secure module 2 to the ceiling at this step.**

14 Fixture Joining

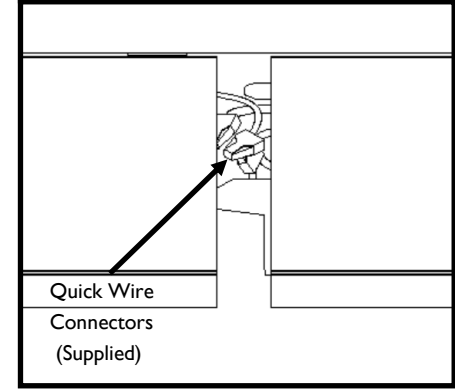

With module 2 supported complete wiring connection using provided quick wire connectors.

! ATTENTION: Install in accordance with national and local building and electrical codes.

15 Fixture Joining

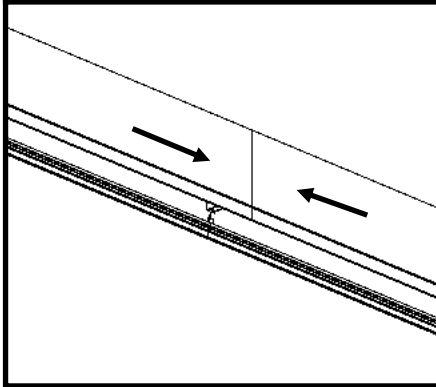

Ensure all connections are secure and all wires are neatly tucked inside fixture wiring cavity. Slide fixture modules together gently. With module 1 and module 2 butted together, secure the non joining end of module 2 to the ceiling.

16 Fixture Joining

- Support open end of module 2 and secure to ceiling brackets as shown in step 11.

17 Fixture Joining

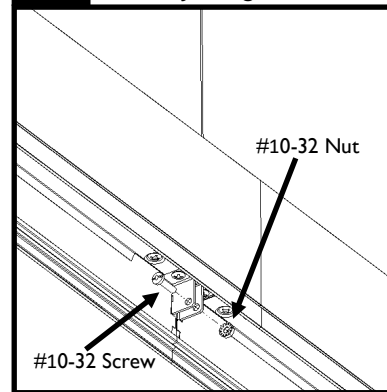

Secure fixture modules together using the two #10-32 machine screws and the two #10-32 nuts supplied. Tighten until joint seam is tight. **Note: Do not overtighten.**

18 Surface Power Feed Connection

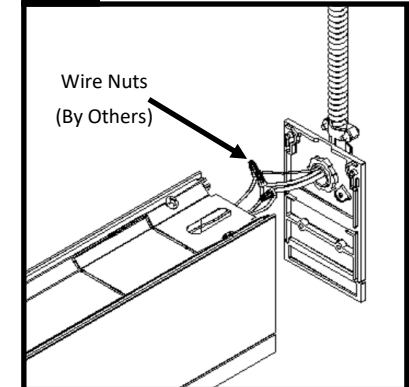

For surface mounted junction box, connect conduit and required connectors (by others) to drilled endcap.

19 Endcap Installation

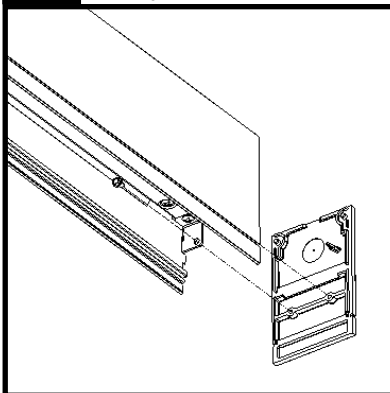

Slide endcap onto end of fixture module and secure from below using two #8-32 X 5/16" screws. Tighten screws until endcap seam is tight. **Note: Do not overtighten.**

20 Finishing

- Ensure all fixtures are level and in line with each other.
- Check that all joint or endcap screws are installed and all seams are tight.
- Power fixtures on and check all modules light up.
- Install lenses.