



by Signify

Linear

TruGroove Recessed

ID-39 Drywall Trim

Installation Instructions

Standalone or Continuous Run in Drywall Ceiling



These instructions review how to install drywall trim versions of TruGroove recessed fixtures. Please refer to layout drawings supplied by Ledalite in conjunction with these installation instructions. The graphics below show the components required.

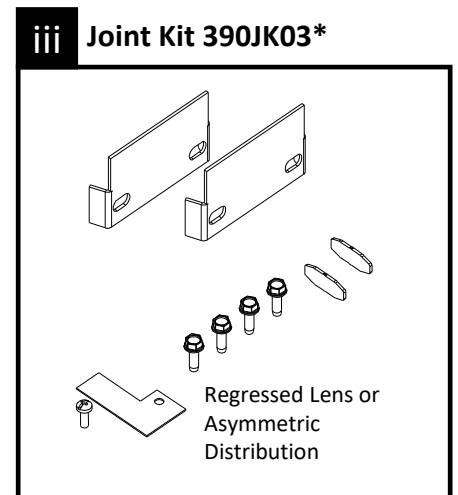
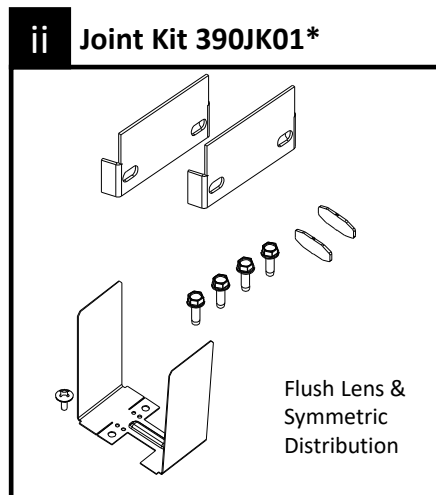
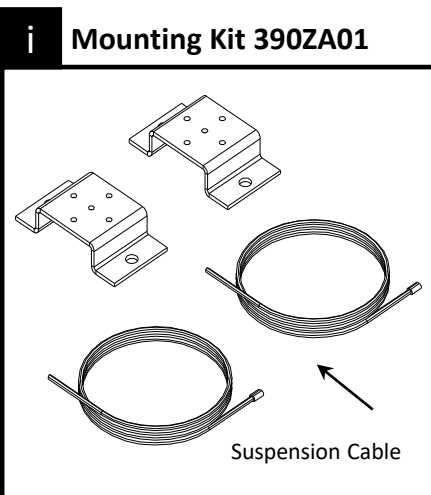
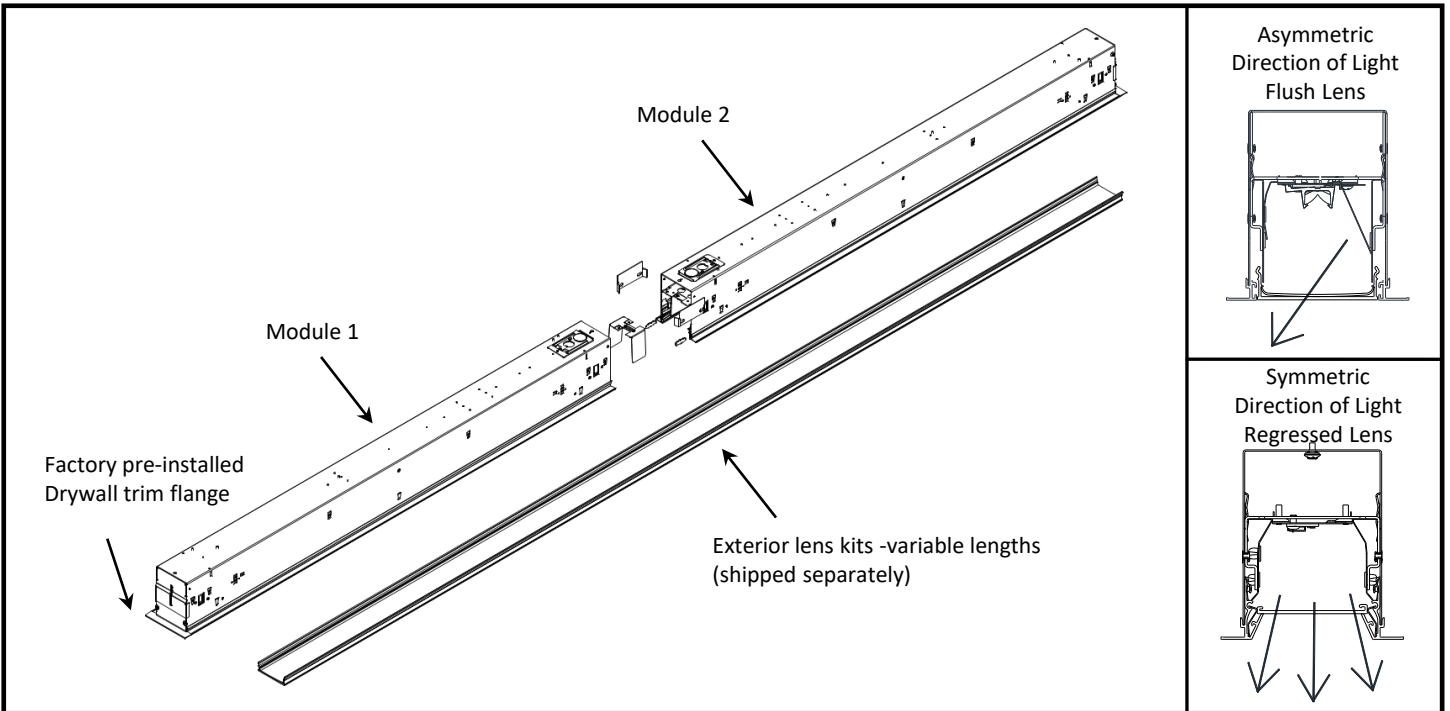

*Note: One kit required for each joint. Joint kit determined by flush or regressed lens mounting and symmetric or asymmetric light distribution.
Tools: Phillips screwdriver, 5/16" Nut Driver

! **ATTENTION: Install in accordance with local and national building and electric codes.**

ID-39 TruGroove Drywall Trim Installation Instructions

Important Notes

i Installation Notes

- 'C' Channels (or equivalent) must be properly braced to ensure accuracy of cut-out in drywall.
- Use appropriate tools to outline specified dimensions of ceiling cut-out to ensure straightness of cutting.
- Lens will not insert properly if fixture trim has mud or paint build-up.

⚠ Warning, Shock Hazard

Fixture must be connected to building ground via the provided ground wire before connecting to mains power supply.



! Avoid

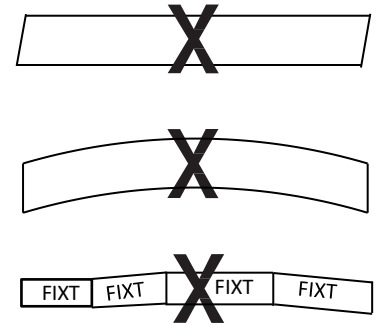

The straightness and accuracy of the cut-out in the drywall is crucial in ensuring proper fit for the fixture.

NOTE: TruGroove modules are designed for installation after ceiling construction.

Prepare Ceiling: Standalone Units

1 Determine Locations

- Determine fixture location and fixture type. Refer to figure A for cut-out length and mount locations. Install mount brackets and suspension cables as shown on page 3.
- Determine power feed location(s) - refer to figure A. Install power feeds as required and drop below installed ceiling height.
- Build ceiling frame around fixture cutout to 3-7/8" to 4" width as shown in figure A.

A Ceiling Cut-out Details

Cut-out Length:

2ft	23-7/8" + 1/4"	3ft	35-7/8" + 1/4"
4ft	47-3/4" + 1/4"	5ft	59-7/8" + 1/4"
6ft	71-5/8" + 1/4"	8ft	95-5/8" + 1/4"



Cutout Width: **MIN 3-7/8"**
MAX 4"

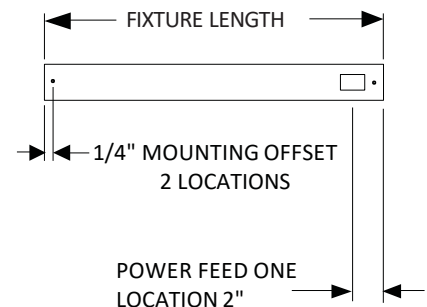

Important: The cut-out **MUST** fall within the specified tolerances.

Important: For 2ft standalone fixtures, end framing members must be installed 1" beyond ceiling cut-out.

! **ATTENTION:** Install in accordance with local and national building and electric codes.

ID-39 TruGroove Drywall Trim Installation Instructions

Prepare Ceiling: Continuous Runs

2 Determine Locations

- Determine fixture location and fixture type. Refer to figure B for mount locations and cut-out length. Install mount brackets and suspension cables as shown below.
- Determine power feed location(s) - refer to layout drawings. Install power feeds as required and drop below installed ceiling height.
- Build ceiling frame around fixture cut-out to 3-7/8" to 4" width as shown in figure B. Refer to layout drawings for ceiling frame length.

B Ceiling Cut-out Details



Cutout Width: **MIN 3-7/8"**
MAX 4"

For continuous run fixtures, the cut-out in the drywall ceiling should be the same size as the overall fixture run length indicated on the layout drawings +1/4".

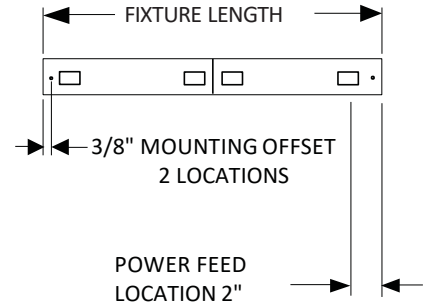

Installation Preparation

3 Mount Kit

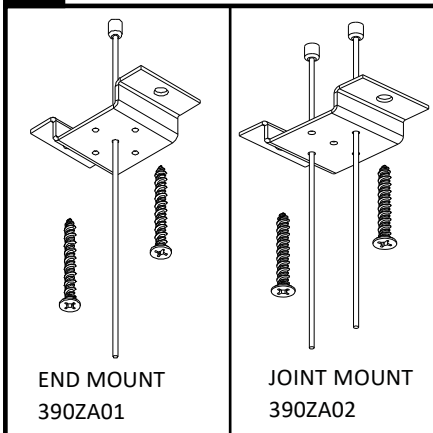

Install mounting brackets, suspension cables and power feed(s) at required locations. Mounting hardware (screws/ fasteners) are supplied by others. Maximum screw size # 10 (.190").

4 Install Mounts and Power Cables

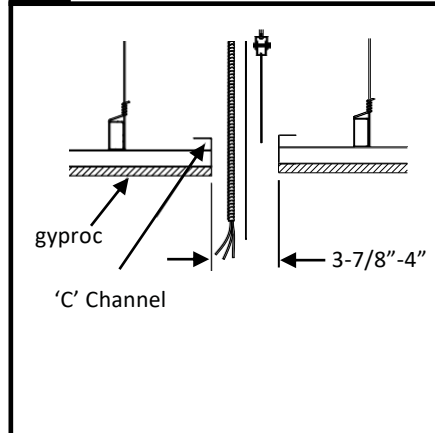

Install a 'C' channel perimeter around the ceiling cutout.

Important: See ceiling cut-out details on page 2 & 3.

5 Install Drywall Ceiling

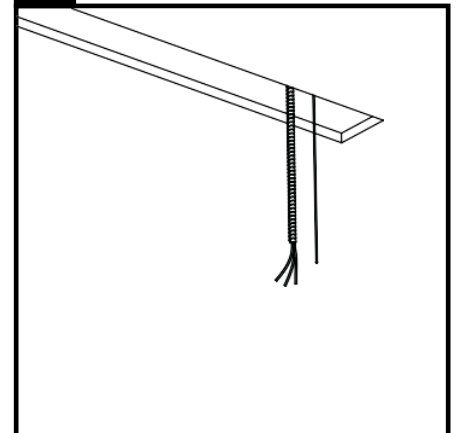

Install drywall ceiling and cut required opening as shown in **figure A** on page 2 or **figure B** on page 3.

! **ATTENTION: Install in accordance with local and national building and electric codes.**

ID-39 TruGroove Drywall Trim Installation Instructions

Install fixtures

6 Prepare Fixtures

Arrange boxed fixtures on floor in specified mounting locations, based on supplied layout drawings. Match up each fixture based on the spec tag and ID number labelled on each fixture box for the specified run.

7 Insert Aircraft Cable

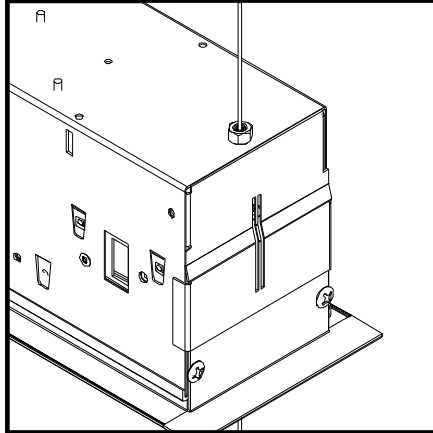

Suspend each module by inserting the aircraft cables through the grippers on top of the housing.

8 Raise Fixture

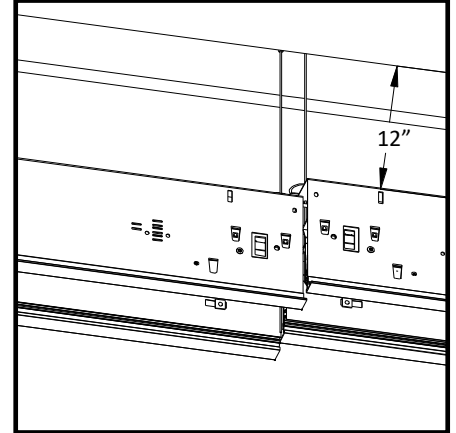

Gradually lift each module to approximately 12 inches below the ceiling.

9 Remove Cover and Feed through Power Wire

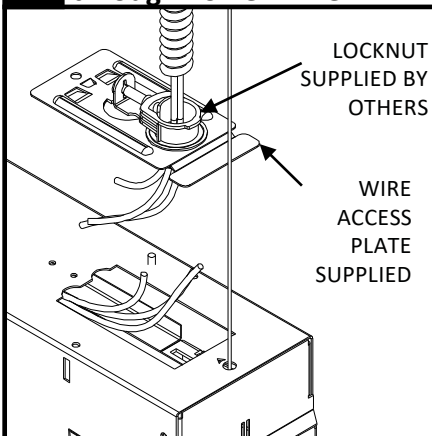

At the power location(s), remove factory installed wire cover. Feed power wires through. Complete all wiring connections.

10 Re-install Wire Cover

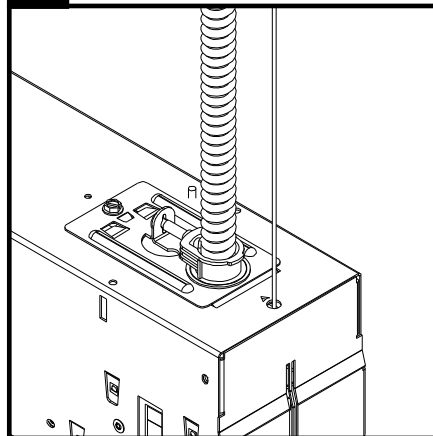

Re-install wire cover and slide to lock. Install screw.

11 Raise and Level Fixtures

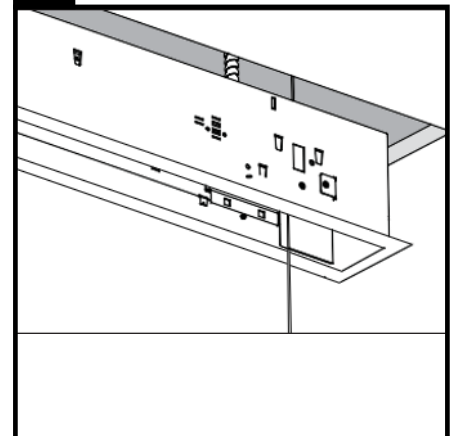

Once the power connections are complete, pull the aircraft cable to raise all modules to just below the ceiling.

Important: Modules must be level relative to each other if joining of sections is required



! **ATTENTION:** Install in accordance with local and national building and electric codes.

ID-39 TruGroove Drywall Trim Installation Instructions

NOTE: For Standalone fixtures skip to step 16

12 Install Joiner Aligners

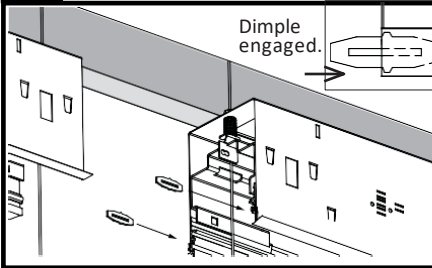

At joint location(s), gently tap provided joiner aligners inside one module only. Two joiner aligners are required for each joint.

Important: To insert aligners, tap gently with a hammer until half is inserted into the joiner channel. Be sure to engage the dimple.

13 Complete Wiring Connections

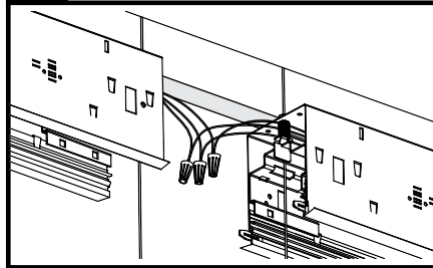

Complete module to module wiring connections and carefully tuck all wires inside the upper wiring cavity.

Important: Pay attention that the fixture to fixture ground wire is connected.

14 Join Individual Modules

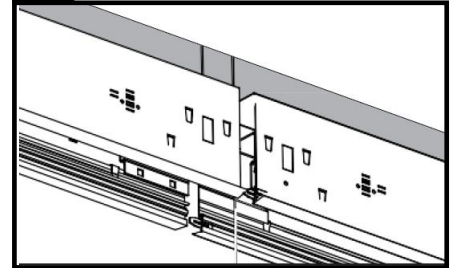

Gently slide housing modules together, ensuring joiner aligners are engaged inside the trim in the adjacent module.

Important: Joiner aligners must be fully inserted to provide proper section alignment.

15 Install Joiner Brackets

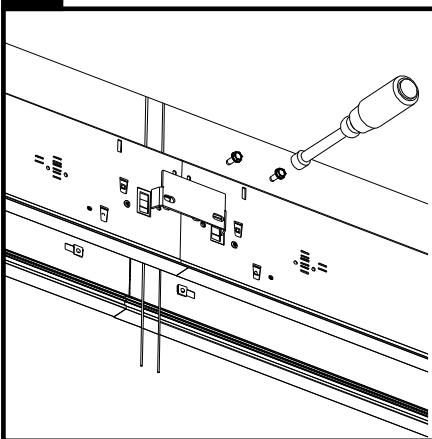

Install joiner brackets on each side of the housing using supplied hardware. **Important:** Hand tighten bracket screws while supporting the housing on the opposite side. Gradually alternate sides while tightening. Do not over tighten.

16 Raise Fixture(s) into Ceiling Cut-out

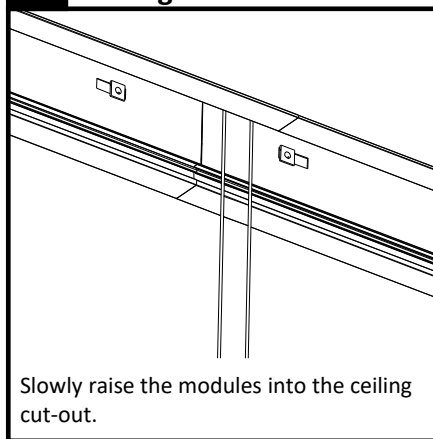

Important: For continuous row modules, start at one end and gradually raise each module up one inch at a time. Repeat process until housing is fully recessed and housing trim touches drywall ceiling. Do not stress the joint connection by tilting the module, as damage can occur.

17 Trim Excess Cable

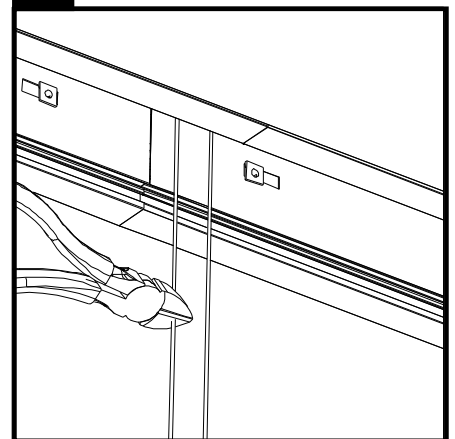

Trim suspension cable approximately 8 inches below the ceiling level. Tuck all excess cable inside the upper wiring cavity.

! **ATTENTION:** Install in accordance with local and national building and electric codes.

ID-39 TruGroove Drywall Trim Installation Instructions

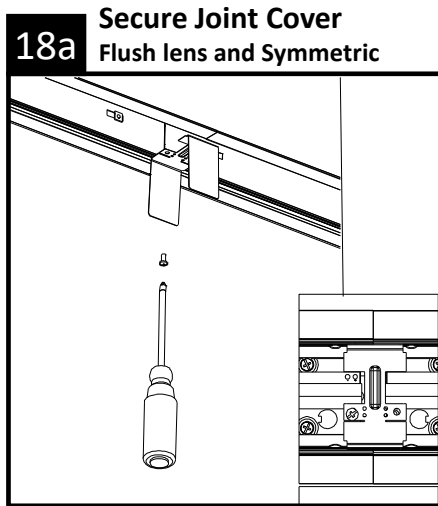

At joint location(s), secure joint covers using Philips screwdriver and supplied hardware. Ensure cover plates sit flush with bottom reflectors for proper LED board fit.

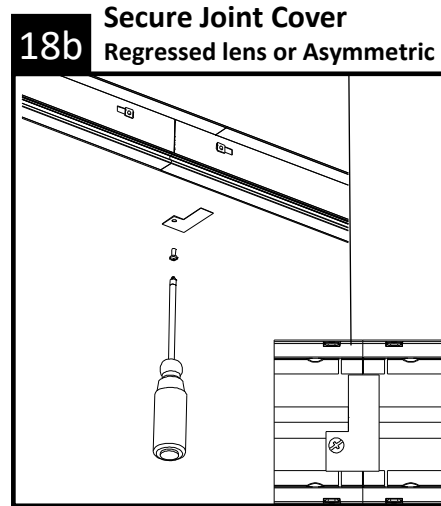

At joint location(s), secure joint covers using Philips screwdriver and supplied hardware. Ensure cover plates sit flush with bottom reflectors for proper LED board fit.

19a Flush Lens Installation and Removal

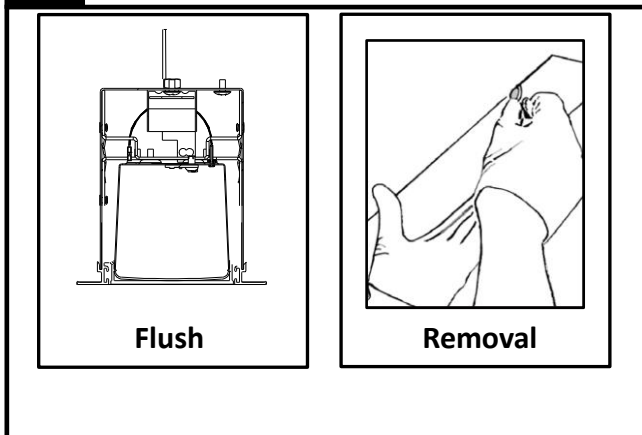

Flush Lens: Snap in lens into fixture.

Lens Removal: To remove snap-in lens for maintenance purposes, insert a flat, smooth edged object between lens and housing. Twist to release pressure and remove lens.

19b Regressed Lens Installation

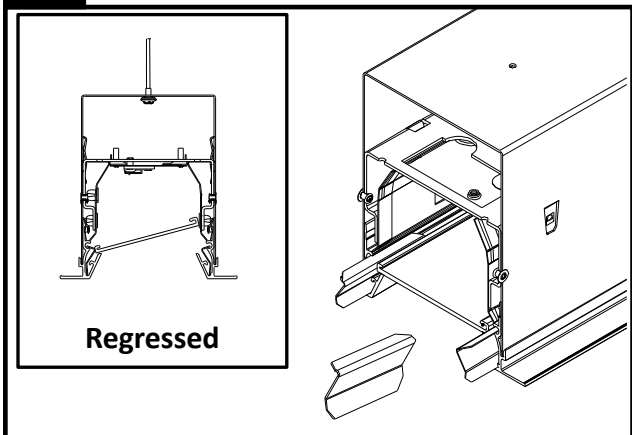

Regressed Lens: Angle lens to insert into fixture. Lay lens on aluminum extrusion flange.

Ensure lens engages between lens retaining clips to prevent movement of lens.

NOTE: Please refer to layout drawing and match up each lens based on the ID number.

! **ATTENTION:** Install in accordance with local and national building and electric codes.

Signify