

A modern street lamp with a silver pole and a glass-enclosed luminaire. The luminaire has a wide, flat, circular top and a clear glass body that houses a white, cylindrical light source. The pole is sleek and cylindrical.

©signify

GrandeVille LED

Nordic design classic for
any urban application

Contents

1. Meet GrandeVille LED
2. Application areas
3. The product basics
4. Product variants
5. One-to-one table
6. Controls hardware solutions
7. Product specifications



Meet GrandeVille LED

With its clean lines and the cylindrical form, GrandeVille LED has been a design classic in the Nordic region. Today it is equipped with efficient LED which allows optimizing energy savings.

GrandeVille LED combines functional and aesthetical characteristics. Being made of impact-resistant materials, the luminaire is ideal for any urban setting.

Highlights:

- Classic design with clean lines
- Robust materials
- Comfortable lighting effect generated indirectly
- Luminaire light output from 920 to 3000 lm



Application areas



Prime application areas

- Residential streets
- Walking/cycling paths
- Squares/plazas
- City center

Secondary application areas

- Parks
- Parking areas
- Industry
- Rural areas



Materials and finishing

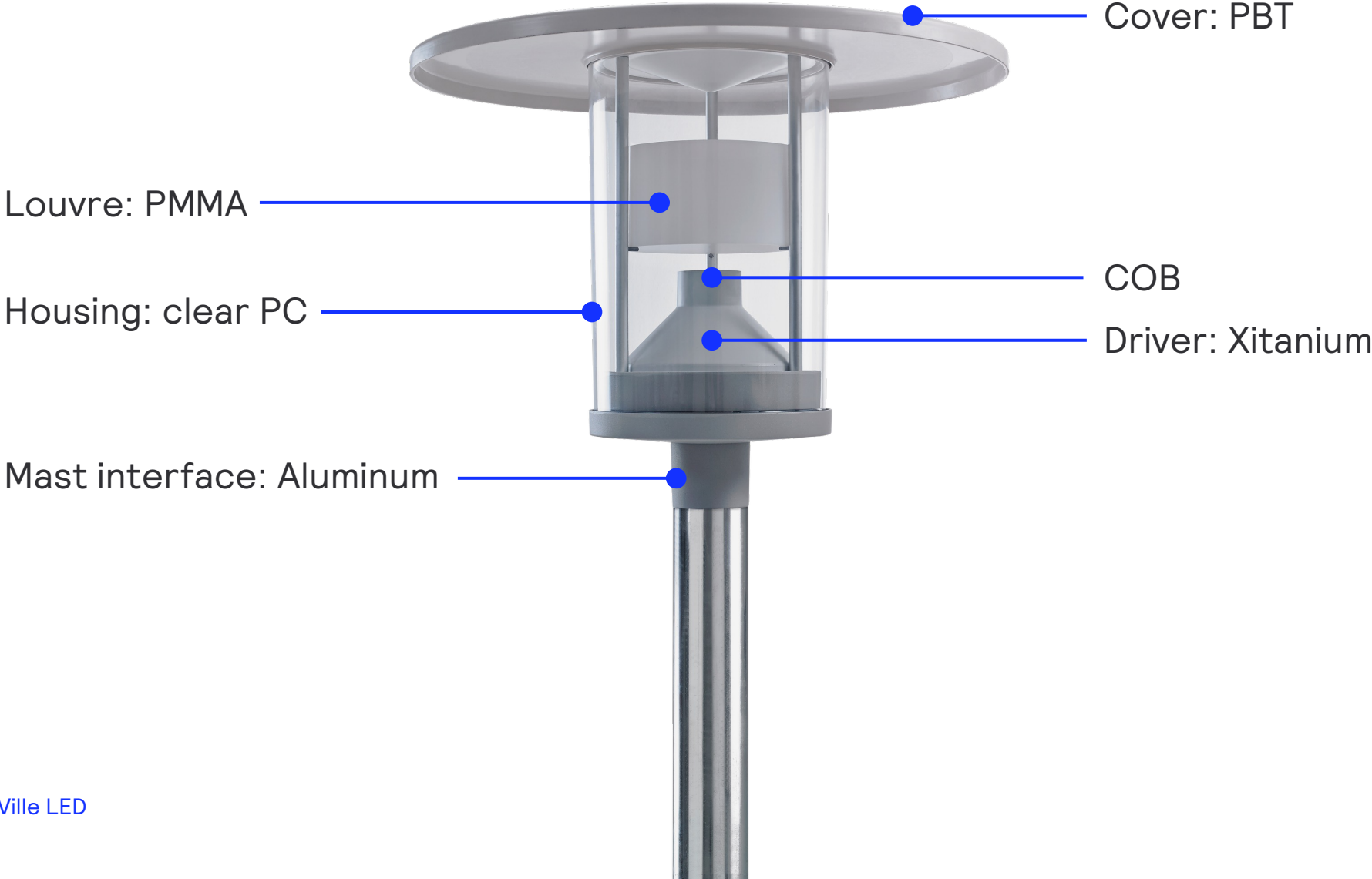

Product variants



Recommended mounting height
3-4 meters

Conversion table: conventional to LED

HPL louvre (LO)	HPL diffuser (DF)	PL-T louvre (LO)	SON(T)/CDO(T) louvre (LO)	SON(T)/CDO(T) diffuser (DF)	3000K	4000K
50W	-	32W	-	-	LED16 - 19W	LED19 - 19W
80W	50W	42W	50W	-	LED29 - 34W	LED34 - 34W
125W	80W	-	70W	50W	LED45 - 53W	LED49 - 53W

Signify Service tag

- A unique QR code-based LED luminaire asset identification system
- Providing detailed information on specification and spare parts, simply by scanning the code on the packaging or luminaire with the Signify Service tag app.
- The system simplifies the installation and maintenance of lighting infrastructure by utilizing cloud technology.
- Service tag also plays a key role in the circular design of our lighting solutions, as it extends their service life and reduces maintenance efforts, ensuring efficient servicing and avoiding waste.

Your benefits at a glance:



Easy installation
and commissioning



Simplified
maintenance



Asset
management



Learn more at [signify.com/global/service-tag](https://www.signify.com/global/service-tag)

Signify Service tag: Installation



#1. Download the app

Download the Service tag app from the App store or Play store on your mobile device (iOS or Android).



#2. Register the luminaire

Register the luminaire by simply scanning the QR code on the packaging or luminaire. The system automatically identifies the type of each luminaire.



#3. Create a group QR code

If you have multiple luminaires, it's possible to use the Service tag app to combine individual luminaires into a group. Each group will have its own unique group QR code.



#4. Luminaire information

Scan the QR code on your luminaire for easy access to the installation manual.

Maintenance

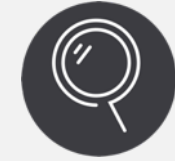

#1. Spare parts identification

Use the Service tag app to view a luminaire's spare parts, which contains all necessary information for quick ordering.



#2. Spare parts programming

Quickly program a spare driver using the Service tag app—without needing a faulty driver on hand. Scan the QR code of a luminaire with your device, put your mobile device on the spare driver, press “Program” and the spare driver receives the right settings for this specific luminaire.



Learn more at
signify.com/global/service-tag

©ignify

©signify

Product specifications

Product features	GrandeVille LED (BPS962)
Weight	7 kg
Color	Mast interface: Grey (RAL7035) Cover: Grey (RAL7035) or White (RAL9010)
Materials and finishing	Aluminum (mast interface), PBT (cover), clear PC (housing), PMMA (louvre, inner cone)
Voltage	220–240V / 50–60Hz
Classifications	IP65, class II, IK10
Installation	Post-top or wall-bracket: Ø60 mm
Connection	Delivered with pre-mounted 4-m-cable
Operating temperature	-30°C - +25°C
Light source	Built-in COB module
Luminaire lumen output	920 – 3000 lm
System power	13 – 40W
Constant light output (CLO)	Available
Lumen efficacy	63 – 83 lm/W
Color rendering index (CRI)	>80
Color temperature	3000K, 4000K

System lifetime (L80B10)	60,000 hrs
Optic	Rotational symmetric, asymmetric with shield
Optical cover	Louvre LO / Opal Louvre LO-O / Diffusor DF
Dimming	DALI, DynaDimmer
Max. windage area	0.09 m
Remarks	Order cover separately

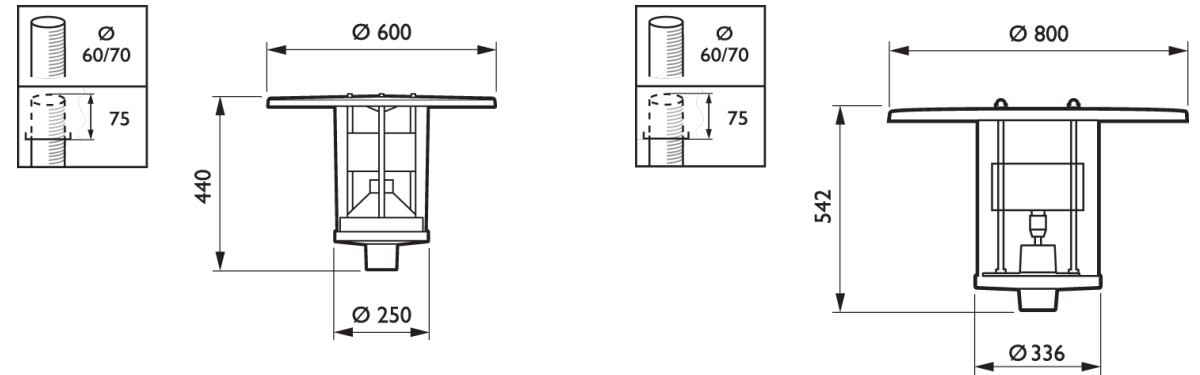

You and Signify – a reliable partnership

Signify is the world leader in connected LED lighting systems, software and services. We proudly bring to market the best lighting brands in the world, including Signify, Philips and Interact.

We believe in close cooperation before, during, and after every project. Our local teams provide the support and information you need—with flexible, on-time delivery and reliable product availability.

To help you stay ahead, the [Signify Lighting Academy](#) offers a comprehensive range of educational resources to grow your expertise and earn certification.

Get more info on our products, services and tools:

[signify.com/installer](https://www.signify.com/installer)

[signify.com/specifier](https://www.signify.com/specifier)

Our global brands

 Signify

Signify represents our commitment to sustainable innovation. As our leading brand for connected lighting systems, luminaires and components for the specification project business, Signify solutions serve the segments where we collaborate most closely with our customers.

 Signify interact

Signify Interact is our IoT software platform for managing smart lighting systems and unlocking the value of the data they collect. Easy to install and configure, Interact supports a wide range of applications—from small offices to entire cities.

PHILIPS

Philips stands for quality and energy efficiency in lighting. It is our leading brand for innovative, off-the-shelf lighting products for professionals and consumers alike.

Get into pole position with high-performance, energy-efficient LED



Signify is Official Lighting Partner
of Mercedes-AMG Petronas F1 Team

Official Lighting Partner



AMG
PETRONAS
FORMULA ONE TEAM

@signify

the meaning of light