



Dimming the next step in energy saving

HF-Regulator Intelligent Touch DALI for TL5/TL-D/PL-L lamps

This intelligent high-frequency electronic dimming ballast utilizes the DALI or Touch and Dim push-button protocol for fluorescent lamps. It meets A1BAT requirements, thereby pre-empting upcoming legislation. With a special command you can retrieve the system's mains power consumption, and with another you can find out which lamp wattage is connected. Combined with controls, additional energy savings can be achieved.

Benefits

- Extremely low stand-by losses, controlled cut-off for dim levels above 80%, hybrid control dimming (current control at 100% and power control at 1%) – combined with MASTER TL5 Eco the most energy-efficient solution
- Extremely low stand-by losses, controlled cut-off for dim levels above 80%, hybrid control dimming (current control at 100% and power control at 1%) – combined with MASTER TL5 Eco the most energy-efficient solution
- HF operation improves light quality and lamp lifetime.
- HF operation improves light quality and lamp lifetime.
- Compliant with European and Asian norms and suitable for emergency lighting systems
- Compliant with European and Asian norms and suitable for emergency lighting systems

HF-Regulator Intelligent Touch DALI for TL5/TL-D/PL-L lamps

Features

- HF-R Intelligent recognizes what type of lamp (T5 HE, HO, ECO, TL-D, PL-L) is connected and drives it accordingly
- HF-R Intelligent recognises what type of lamp (T5 HE, HO, ECO, TL-D, PL-L) is connected and drives it accordingly
- Programmed start: flicker-free ignition < 1.0 second and striation-free operation, no stroboscopic effects. Preheating the lamp electrodes enables the lamps to be switched on and off without reducing life
- Programmed start: flicker-free ignition < 1.0 second and striation-free operation, no stroboscopic effects. Preheating the lamp electrodes enables the lamps to be switched on and off without reducing life
- Smart power ensures constant light, independent of mains fluctuations and dimming from 1 to 100%
- Smart power ensures constant light, independent of mains fluctuations and dimming from 1 to 100%
- Stop circuit is activated within 5 seconds in the event of lamp failure (safety stop), and ballast resets automatically after lamp replacement
- Stop circuit is activated within 5 seconds in the event of lamp failure (safety stop), and ballast resets automatically after lamp replacement
- Programmable for intelligent functionalities via Philips MultiOne: Corridor mode, Emergency DC dim level, Burn-in time
- Programmable for intelligent functionalities via Philips MultiOne: Corridor mode, Emergency DC dim level, Burn-in time

Application

- Indoor, general and task lighting applications in combination with lighting control systems (personal control, daylight linking and/or movement detection)
- Indoor, general and task lighting applications in combination with lighting control systems (personal control, daylight linking and/or movement detection)

Dimensional drawing

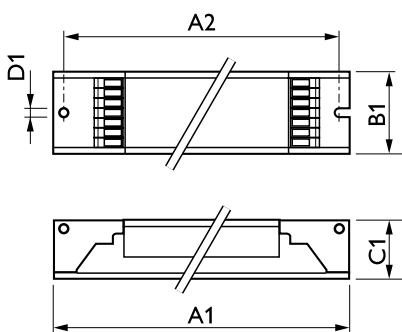

Product	D1	C1	A1	A2	B1
HF-Ri TD 1 28/35/49/54 TL5 E+ 195-240V	4.1 mm	22.0 mm	360.0 mm	350.0 mm	30.0 mm
HF-Ri TD 2 28/35/49/54 TL5 E+ 195-240V	4.1 mm	22.0 mm	360.0 mm	350.0 mm	30.0 mm

HF-Regulator Intelligent Touch DALI for TL5/TL-D/PL-L lamps

Operating and Electrical

Input Frequency	50 to 60 Hz
Input Voltage	195-240 V
Line Frequency	50 to 60 Hz

Mechanical and Housing

Housing	L 359x30x21
---------	-------------

Approval and Application

Energy Efficiency Index	A1 BAT
-------------------------	--------

Operating and Electrical

Order Code	Full Product Name	Number of Products on MCB (16A Type B) (Nom)
913700695666	HF-Ri TD 1 28/35/49/54 TL5 E+ 195-240V	39

Order Code	Full Product Name	Number of Products on MCB (16A Type B) (Nom)
913700695866	HF-Ri TD 2 28/35/49/54 TL5 E+ 195-240V	18

