



An energy-efficient solution

HF-Performer III for TL-D lamps

HF-Performer III TLD is a sustainable, slim and high-frequency electronic ballast for TL-D fluorescent lamps. It is ideal for applications where high energy efficiency is required. The HF-Performer III range has a robust design, meets all relevant international safety and performance standards and is energy-efficient (CELMA EEI A2).

Benefits

- Exceptional energy efficiency with striation-reduction technology in lighting systems at lower temperatures
- The programmed start enables the lamp to be switched on and off without reducing useful lamp life.
- Maximum reliability in system operation
- DC emergency operation in line with IEC/EN 60598-2-22 luminaire norms
- Provides extended lamp life in frequent-switching applications
- Smart power ensures constant light, irrespective of mains-voltage fluctuations
- Suitable for luminaires in protection class I and, after testing, class II
- The universal connector Wago 251 offers the flexibility for horizontal-manual or push-in robot wiring or vertical ALF-robot wiring.

HF-Performer III for TL-D lamps

Features

- Highest CELMA Energy Efficiency Index A2 BAT
- 50,000-hour lifetime at maximum case temperature, combined with over 60,000 on/off switches on one lamp
- Complies with CE, ENEC, EL, VDE-EMC, CCC marks of conformity
- Programmed, flicker-free, pre-heated start (< 1.0 s) which allows the lamp to be switched on and off without reducing useful lamp life
- Average nominal service lifetime over 100,000 hours (at Ta 50 °C) with a failure rate $\leq 0.1\%$ per 1,000 hours)
- Active power factor correction to ensure constant light, irrespective of mains-voltage fluctuations
- Optimized lamp preheating for over 50,000 On/Off switch operations without replacement of lamps
- The unit is protected against excessive mains voltage and incorrect connections.

Application

- Suitable for DC operation and emergency lighting installations; full compliance with requirements for emergency lighting according to EN 61347-2-3 -annex J
- Used with movement-detection control systems like Philips OccuPlus
- For applications with high switching activity, e.g. where movement-detection control devices are used
- Indoor applications, such as office buildings, hospitals, supermarkets, department stores, industrial premises and schools
- For luminaires of protection class I and protection class II used in office buildings, hospitals, supermarkets, department stores, industrial premises and schools
- Class I outdoor applications, e.g. industrial premises and parking lots

Versions



Lamp Driver, eFluo, HF-P 136 TL-D
III 220-240V 50/60Hz IDC



Lamp Driver, eFluo, HF-P 158 TL-D
III 220-240V 50/60Hz IDC



Lamp Driver, eFluo, HF-P 236 TL-D
III 220-240V 50/60Hz IDC

HF-Performer III for TL-D lamps

Dimensional drawing

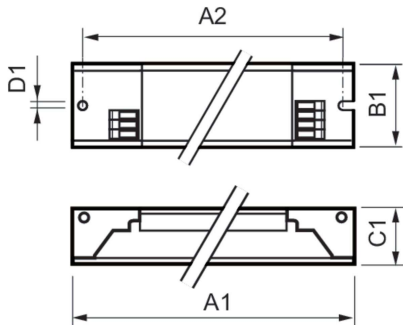

Product	D1	C1	A1	A2	B1
HF-P 118/136 TL-D III 220-240V 50/60 Hz	4.2 mm	28.0 mm	280.0 mm	265.0 mm	30.0 mm
HF-P 158 TL-D III 220-240V 50/60Hz IDC	4.2 mm	28.0 mm	280.0 mm	265.0 mm	30.0 mm
HF-P 218/236 TL-D III 220-240V 50/60 Hz	4.2 mm	28.0 mm	280.0 mm	265.0 mm	30.0 mm

