



Unsurpassed energy-efficient and long-lasting solution

HF-Performer III for TL-D lamps

HF-Performer III TL-D III ballasts offer maximum versatility and meet all of the necessary commercial grade specifications. They also offer the added benefits of lamp striation reduction technology, making these ballasts compatible with energy-saving lamps. As such, these ballasts are part of an overall high-efficiency lighting system that may help you or your customers to achieve any international or local energy code you need to comply with. HF-Performer III TL-D III ballasts are the ideal choice for a broad range of new construction and retrofit applications within the commercial sector, including general surface mounting or office lighting, parking garages, warehouses, waterproof and other applications.

Benefits

- Exceptional energy efficiency with striation-reduction technology in lighting systems at lower temperatures
- Maximum reliability in system operation
- Provides extended lamp life in frequent-switching applications

Features

- Highest CELMA Energy Efficiency Index A2 BAT
- Complies with CE, ENEC, EL, VDE-EMC, CCC marks of conformity
- Average nominal service lifetime over 100,000 hours (at Ta 50 °C) with a failure rate $\leq 0.1\%$ per 1,000 hours)
- Optimized lamp preheating for over 50,000 On/Off switch operations without replacement of lamps

HF-Performer III for TL-D lamps

Application

- Suitable for DC operation and emergency lighting installations; full compliance with requirements for emergency lighting according to EN 61347-2-3 -annex J
- For applications with high switching activity, e.g. where movement-detection control devices are used
- For luminaires of protection class I and protection class II used in office buildings, hospitals, supermarkets, department stores, industrial premises and schools

Versions



Lamp Driver, eFluo, HF-P 3/418
TL-D III 220-240V 50/60Hz IDC



Lamp Driver, eFluo, HF-P 136 TL-D
III 220-240V 50/60Hz IDC



Lamp Driver, eFluo, HF-P 158 TL-D
III 220-240V 50/60Hz IDC



Lamp Driver, eFluo, HF-P 236 TL-
D III 220-240V 50/60Hz IDC



Lamp Driver, eFluo, HF-P 258 TL-
D III 220-240V 50/60Hz IDC

Dimensional drawing

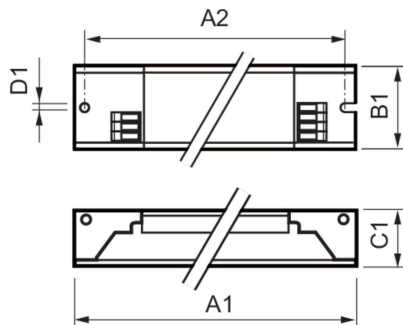

Product	D1	C1	A1	A2	B1
HF-P 118/136 TL-D III 220-240V 50/60 Hz	4.2 mm	28.0 mm	280.0 mm	265.0 mm	30.0 mm
HF-P 158 TL-D III 220-240V 50/60Hz IDC	4.2 mm	28.0 mm	280.0 mm	265.0 mm	30.0 mm
HF-P 218/236 TL-D III 220-240V 50/60 Hz	4.2 mm	28.0 mm	280.0 mm	265.0 mm	30.0 mm
HF-P 258 TL-D III 220-240V 50/60Hz IDC	4.2 mm	28.0 mm	280.0 mm	265.0 mm	30.0 mm
HF-P 3/418 TL-D III 220-240V 50/60Hz IDC	4.2 mm	28.0 mm	280.0 mm	265.0 mm	40.0 mm

HF-Performer III for TL-D lamps

Operating and Electrical

Input Frequency	50 to 60 Hz
Input Voltage	220 to 240 V
Line Frequency	50 to 60 Hz

Approval and Application

Energy Efficiency Index	A2 BAT
-------------------------	--------

Operating and Electrical

Order Code	Full Product Name	Number of Products on MCB (16A Type B) (Nom)
91162600	HF-P 3/418 TL-D III 220-240V 50/60Hz IDC	28
91164000	HF-P 118/136 TL-D III 220-240V 50/60 Hz	28
91170100	HF-P 158 TL-D III 220-240V 50/50Hz IDC	28

Order Code	Full Product Name	Number of Products on MCB (16A Type B) (Nom)
91166400	HF-P 218/236 TL-D III 220-240V 50/60 Hz	28
91172500	HF-P 258 TL-D III 220-240V 50/60Hz IDC	12

Mechanical and Housing

Order Code	Full Product Name	Housing
91162600	HF-P 3/418 TL-D III 220-240V 50/60Hz IDC	L 280x40x28
91164000	HF-P 118/136 TL-D III 220-240V 50/60 Hz	L 280x30x28
91170100	HF-P 158 TL-D III 220-240V 50/50Hz IDC	L 280x30x28

Order Code	Full Product Name	Housing
91166400	HF-P 218/236 TL-D III 220-240V 50/60 Hz	L 280x30x28
91172500	HF-P 258 TL-D III 220-240V 50/60Hz IDC	L 280x30x28

