



# LuxSpace square, recessed – high efficiency, visual comfort and a stylish design

## LuxSpace square, recessed

Customers are looking to optimize all their resources, and that means not just their running costs (energy, etc.) but also their human resources. Energy savings are therefore a priority, but they must not have an adverse effect on the well-being of employees, who need a pleasant environment in order to be more productive, or on customers, who want to enjoy their shopping experience. LuxSpace provides the perfect combination of efficiency, light comfort and design, without compromising on lighting performance (color rendering and color uniformity). It offers a wide choice of options for creating the desired ambience, no matter the application.

### Benefits

- Best-in-class efficacy
- Creates a gentle, natural light, ensuring visual comfort
- Perfect integration with the ceiling thanks to the thin, narrow rim; rimless version ideal for integration into plaster ceilings

# LuxSpace square, recessed

## Features

- Choice of four optics: high-gloss, faceted, matt and white
- Rim colors: high-gloss metalized, white (RAL9010), grey, black (RAL9004) as standard (any other RAL color possible upon request)
- Rimless version available
- Compliant for central emergency lighting with DC
- Multiple additional options: emergency lighting (single battery 3 hours), through-wiring

## Application

- Offices
- Retail
- Hospitals
- Hotels
- Airports

## Versions



IPPR DN570Bi 0051

## Dimensional drawing

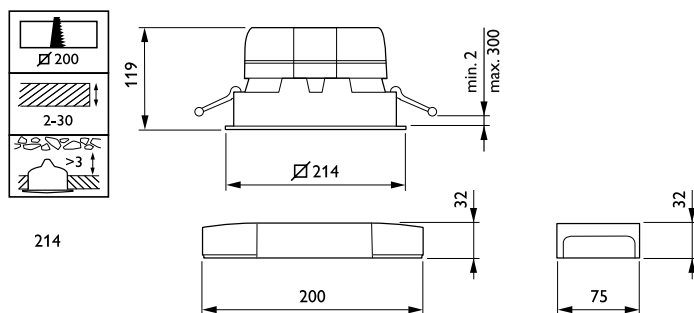

# LuxSpace square, recessed

## General Information

Driver included	Yes
Light source replaceable	No
Number of gear units	Unit
Service Tag	Yes

## Light Technical

Correlated Colour Temperature (Nom)	4000 K
Colour rendering index (CRI)	>80
Optic type	-

## Operating and Electrical

Protection class IEC	Safety class II
Input Voltage	220 to 240 V
Line Frequency	50 to 60 Hz
Suitable for random switching	Yes

## Mechanical and Housing

Housing Colour	White
Mech. impact protection code	IK02
Ingress protection code	IP20

## Approval and Application

Ambient temperature range	+10 to +25 °C
CE mark	Yes
ENEC mark	ENEC mark
Flammability mark	For mounting on normally flammable surfaces
Glow-wire test	Temperature 650 °C, duration 30 s

## Initial Performance (IEC Compliant)

Initial chromaticity	(0.38, 0.38) SDCM <2
Luminous flux tolerance	+/-10%

## Product Data

Product family code	DN572B
---------------------	--------

## Light Technical

Order Code	Full Product Name	Luminous efficacy (rated) (nom.)	Luminous Flux
910505100944	DN572B LED12S/840UE PSU-E C WH	160 lm/W	1,250 lm
910505100950	DN572B LED20S/840UE DIA-VLC-E C WH	173 lm/W	2,200 lm
910505100952	DN572B LED24S/840UE PSU-E C WH	173 lm/W	2,500 lm

## Operating and Electrical

Order Code	Full Product Name	Power Consumption
910505100944	DN572B LED12S/840UE PSU-E C WH	7.9 W
910505100950	DN572B LED20S/840UE DIA-VLC-E C WH	12.8 W

Order Code	Full Product Name	Power Consumption
910505100952	DN572B LED24S/840UE PSU-E C WH	14.8 W

## Controls and Dimming

# LuxSpace square, recessed

Order Code	Full Product Name	Dimmable	Embedded control	Maximum dim level
910505100944	DN572B LED12S/ 840UE PSU-E C WH	No	-	-
910505100950	DN572B LED20S/ 840UE DIA-VLC-E C WH	Yes	Visible light communication	1%

Order Code	Full Product Name	Dimmable	Embedded control	Maximum dim level
910505100952	DN572B LED24S/ 840UE PSU-E C WH	No	-	-

## Polar Wide Diagrams

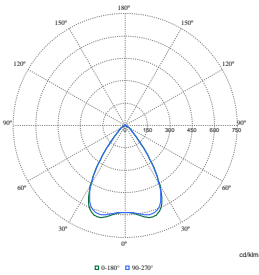

Polar Normal (separate) - DN572BI -  
910505100950

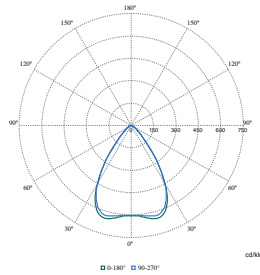

Polar Normal (separate) - DN572BI -  
910505100944

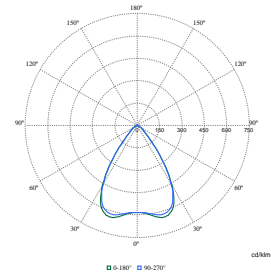

Polar Normal (separate) - DN572BI -  
910505100952

