



Product Description

MASTER MHN-FC

Compact quartz metal halide lamps with double pinch

Benefits

- Allows compact luminaire systems with precision optics for minimal light spill
- Good color rendering creates a pleasant ambience with high visual comfort for players and spectators
- Continuous spectral distribution offers options for semi-professional stadiums and area lighting

Features

- Double-pinch concept results in long lifetime
- Choice of 1000 W and 2000 W types
- Natural white color appearance
- Compact light source allows small luminaire design

Application

- Recreational sports and area floodlighting

Warnings and Safety

- Use only in totally enclosed luminaire, even during testing (IEC61167, IEC 62035, IEC60598)
- The luminaire must be able to contain hot lamp parts if the lamp ruptures
- A lamp breaking is extremely unlikely to have any impact on your health. If a lamp breaks, ventilate the room for 30 minutes and remove the parts, preferably with gloves. Put them in a sealed plastic bag and take it to your local waste facilities for recycling. Do not use a vacuum cleaner.

MASTER MHN-FC

Versions



LPPR MHN-FC 2000W 2200W

LPPR MHN-FC 1000W

Dimensional drawing

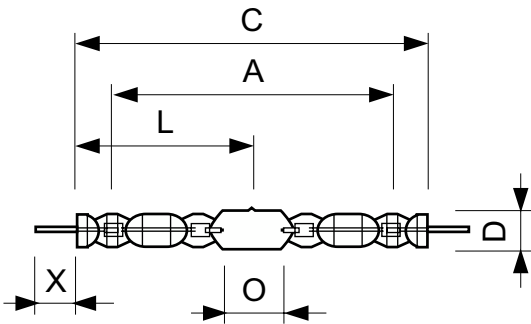

Product	D (max)	D	O	X	L	A	C (max)
MASTER MHN-FC 1000W/740 230V XW	33 mm	25.5 mm	42.5 mm	58 mm	144 mm	226 mm	290 mm
MASTER MHN-FC 2000W/740 400V XW	33 mm	25.5 mm	108 mm	58 mm	177 mm	290 mm	357 mm

General Information

Cap base Double Ended

Operating position P5

Light Technical

Colour designation White (WH)

Controls and Dimming

Dimmable No

Mechanical and Housing

Lamp Finish Clear

Light Technical

Order Code	Full Product Name	Chromaticity Coordinate X (Nom)	Chromaticity Coordinate Y (Nom)	Correlated Colour Temperature (Nom)	Colour rendering index (CRI)	Luminous efficacy (rated) (nom.)
928070405130	MASTER MHN-FC 2000W/740 400V XW	380	419	4200 K	60	102 lm/W
928075705130	MASTER MHN-FC 1000W/740 230V XW	374	366	4100 K	65	91 lm/W

Operating and Electrical

MASTER MHN-FC

Order Code	Full Product Name	Voltage (nom.)	Power Consumption
928070405130	MASTER MHN-FC 2000W/740 400V XW	222 V	2,050 W

Order Code	Full Product Name	Voltage (nom.)	Power Consumption
928075705130	MASTER MHN-FC 1000W/740 230V XW	130 V	1,040.0 W

Approval and Application

Order Code	Full Product Name	Energy consumption kWh/1,000 hours	Mercury (Hg) content (nom.)
928070405130	MASTER MHN-FC 2000W/740 400V XW	2,235 kWh	105 mg

Order Code	Full Product Name	Energy consumption kWh/1,000 hours	Mercury (Hg) content (nom.)
928075705130	MASTER MHN-FC 1000W/740 230V XW	1,144 kWh	74 mg

