



Specification Sheet

LFC7510/00 Current

The Current is a client interface module in the Cabinet Controls. It is a highly reliable monitoring device designed for detecting asymmetrical earth leakage in electrical systems and for monitoring current changes in each phase of up to two three-phase circuits. For this purpose, one leakage transformer and two three-phase current transformers can be connected to the module. Leakage and current threshold values can easily be configured to fit specific needs in the AmpWeb server application that runs on a central server. The Current can be used for a wide range of monitoring purposes. In the Cabinet Controls, this module is used for monitoring the individual control cabinets. Power failures, cable breakages, lamp failures, leakages, and so on are immediately reported to the central server. All modules in the Cabinet Controls incorporate an A-Bus interface which is based on the industrially proven RS-485 technology. The A-Bus interface is used for power supply and for direct communication between the modules.

For more detailed information, see the specific manuals and guides.

LFC7510/00

Dimensional drawing

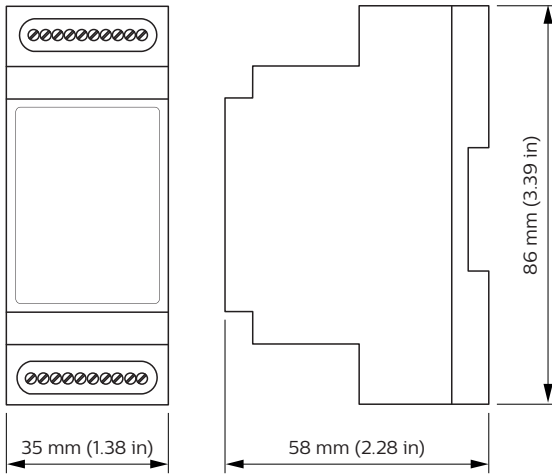

Functionality

Communication	A-Bus two-way communication with A-Bus masters (the SCU).
Auto discovery	The module is automatically discovered by the SCU. In case a module is disconnected from the SCU, this is reported to the server application, and the module is listed as missing. If the module is reconnected to the SCU or another SCU, it will be rediscovered.
LED	Status LED (green): indicates whether the A-Bus is up and running.

Functional specifications

A-Bus	A-Bus client module, check SCU specification for details.
Leakage current	Input range: 1 to 15 mA, rel. accuracy: $\pm 0.3\%$ FSD, abs. accuracy $\pm 5\%$ FSD.
Sensor input	Detection range: 170 to 1000 mA. Use with LCU7591 Leak Coil only.
3-phase	Input range: 1 to 100 mA, rel. accuracy: 0.3% FSD, abs. accuracy $\pm 5\%$ FSD.
Current sensor input(s)	Detection range: 5 to 65 A. Use with LCU7590 3-Phase Coil only.
Measurement type	RMS, mean, peak
Frequency range	50/60 Hz

Reliability & Maintainability

Software upgrade	The software on the Current can be updated remotely from the central server.
Installation of new software	New software is transferred without interrupting the normal functionality of the Current. When the software has been transferred, the integrity of the software is checked and the software is installed.
Self-test	A built-in self-test is performed after power-up.
Watchdog and brown-out reset	Watchdog and brown-out reset ensure that the system is up and running at all times.

Installation

The Current should be protected from dust and water, preferably by enclosing the system in a metal IP class 65 (NEMA type 4) outdoor cabinet.

Use the Current with current transformers LCU7590 and LCU7591 only.

Use shielded cables, with the shield connected to GND (pins 5 and 10 for the A-Bus). If the use of shielded cables is not possible keep the cable length as short as possible, and avoid placement close to sources of interference, such as RF antennas and mains power lines.

A-Bus cable	Use shielded twisted pair (2x2) cable The Current can be connected to any master module in the Cabinet Controls, (the SCU). Double connections on the A-Bus makes daisy-chaining of the signals easy. For detailed information, see wiring diagrams.
A-Bus cable length	< 3 m (10 ft)
Switch connection cable length	< 3 m (10 ft)
Switch connection cable	Use copper conductors only and wires rated of 65 °C (149 oF) minimum.

⚠ Attention

Make sure all sensor wires are connected and don't leave wires of the sensors floating!
Never connect the sensor wires while mains is connected!

Wiring

A-Bus connection:
Shielded twisted pair (2x2) cable
Max. 3 m (10 ft)

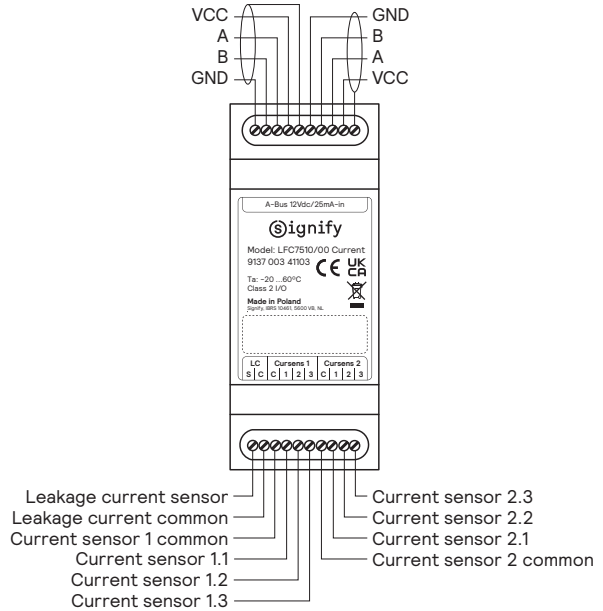

Current and leakage sensor connection

Terminals: 0.5 mm² (AWG 20)

Specifications

Environmental conditions

Storage temperature	-40 to 85 °C (-40 to 185 °F)
Operating temperature	-20 to +60 °C (-4 to 140 °F)
Max humidity	90% (non-condensing)

Supply characteristics

Input voltage	12 Vdc via A-Bus
Current	Typical 20 mA Maximum 25 mA

Mechanical

Housing	Top part Gray (RAL 7035) Lexan 940 Base part Black (RAL 7021) Noryl VO 1550 Coating Conformal coated
Mounting	DIN-rail (EN50022)
Weight	51 g (1.8 oz)

Robustness and reliability

Operational lifetime	70,000 hrs
Lifetime failure rate	<=10%

Packing data

Type	Box dimensions	Qty	Material	Weight	
				net	gross
LFC7510/00	395 x 290 x 205 mm (15.6 x 11.4 x 8.1 in)	60	Cardboard	3.06 kg (6.75 lb)	3.9 kg (8.6 lb)

Ordering Data

Type	MOQ	Ordering number	EAN code level 1	EAN code level 3	EOC
LFC7510/00 Current	1	9137 003 41103	8727900 947502	8727900 947519	947502 00

Connections

A-Bus and Sensor connector	0.14 to 0.5 mm ² (AWG 26 to 20) solid/stranded; copper conductors only, wire rating 65 °C (149 °F) min.; wire strip length: 4.5 mm; screwdriver, bladed, size 0.4 x 2.0 mm; tightening torque: min 0.12 Nm, max 0.15 Nm (1.1 to 1.3 lb in)
----------------------------	---

Standards and approvals

2006/95/EC, Low Voltage Directive (LVD)
2004/108/EC, EMC Directive
2002/95/EC, RoHS Directive
2006/121/EC, REACH directive
UL 916
C22.2 No.205-M1983



© 2019–2025 Signify Holding. All rights reserved. The information provided herein is subject to change, without notice. Signify does not give any representation or warranty as to the accuracy or completeness of the information included herein and shall not be liable for any action in reliance thereon. The information presented in this document is not intended as any commercial offer and does not form part of any quotation or contract, unless otherwise agreed by Signify.

All trademarks are owned by Signify Holding or their respective owners.

