

PHILIPS



Fortimo

LED system

FastFlex
LED module

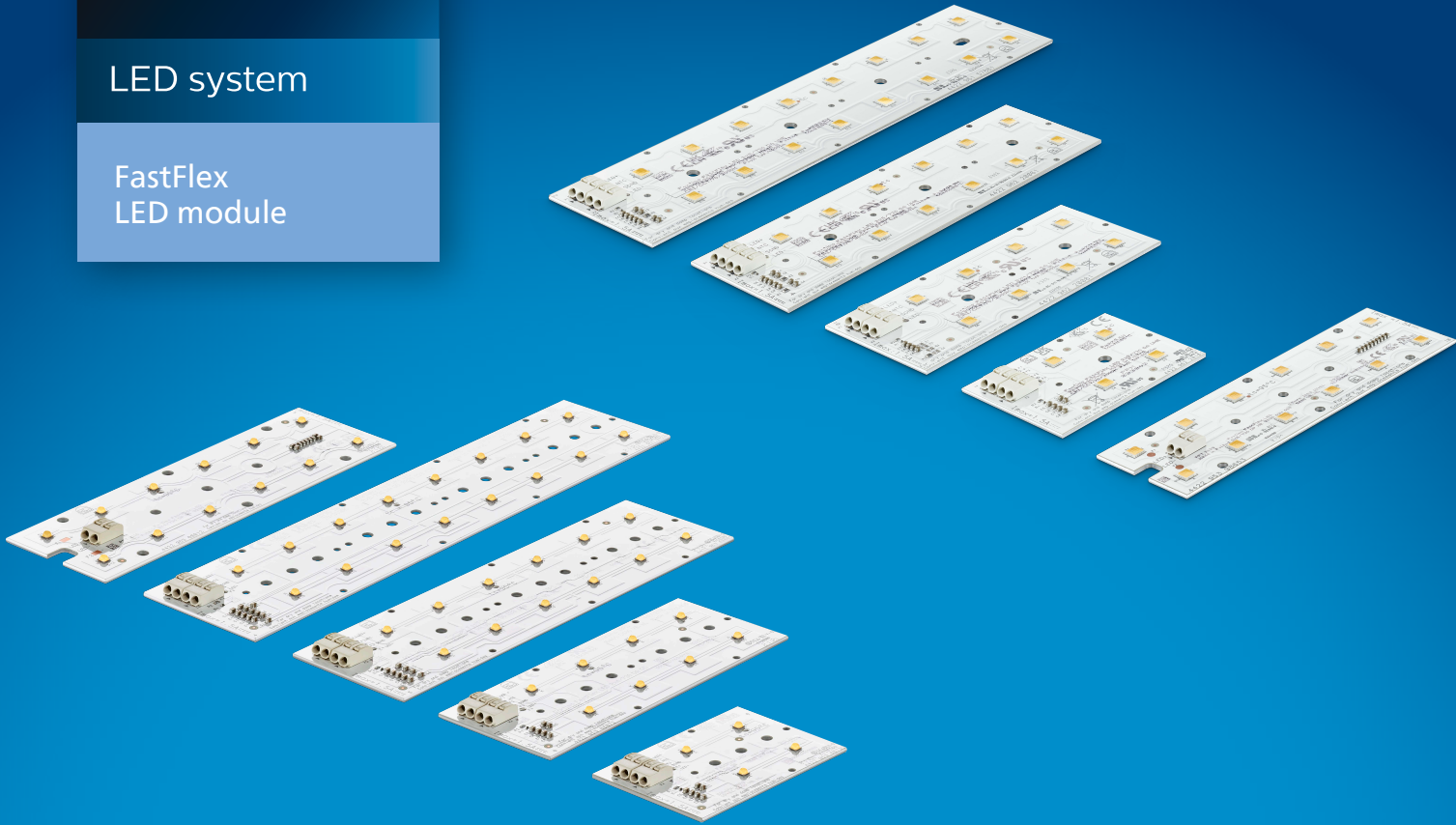

Design-in Guide

FastFlex

Flexible system approach

March 2026

Contents

Introduction to this guide	3	FastFlex LED module assembly	11
Information and support	3	Mounting hole pattern	11
Applications	4		
Product Range	4	Installation instructions	12
		Mechanical fixation	12
Recommendations	5	Fixation of the module	12
Design-in phase	5	Fixation of the complete module inside the luminaire	13
Design-in and manufacturing phase	5	Fixation of the driver	13
Installation and service phase of luminaires	5	Connection between module and driver	13
		Module replacement	14
Controllability	6	Using a long cable in combination with the FastFlex LED module system	14
Default controlling protocols	6	Luminaire isolation Class I and Class II applications	14
Controlling FastFlex LED module with Xitanium LED drivers	6	Surge protection in a FastFlex LED system	14
Which Philips controls can be used?	6		
		Wiring	15
Thermal management	7		
Thermal specifications	7	Quality	16
Operating temperature	7	Compliance and approval marks	16
Thermal de-rating	7	Complementary partners	16
Thermal measurements	8	Sustainability	16
Critical temperature point (T_{case})	8	Warranty	16
Measurement of critical temperature point	8	IP rating, humidity and condensation	16
Critical module temperature with respect to CLO	9	Photobiological safety	16
Heat sink design	9	EMC	17
Heat sink material	9	Electrostatic discharge (ESD)	17
Thermal radiation and emissivity coefficient	9	Remote system operation	17
Thermal interface	10	Use of circuit breakers: Xitanium LED drivers	17
Important points for luminaire design	10	Note on conditions: storage, transportation & operation	17
Xitanium LED driver temperature	10	During operation	17
Critical driver temperature point with respect to CLO	10	System disposal	17
NTC and thermal design	10		
		Disclaimer	18

Introduction to this guide



Fortimo FastFlex LED module 2x8, 2x6, 2x4, 2x2 DA Gx



Fortimo FastFlex LED module 2x6 DP Gx



Fortimo FastFlex LED module 2x8, 2x6, 2x4 or 2x2 DA (U)HE, DA Color Revive, DA Night Glow and DA Color Amb.



Fortimo FastFlex LED module 2x6 DP (U)HE, DA Night Glow and DA Color Amb.



Fortimo FastFlex LED module 4x16 DHE

Thank you for choosing the Fortimo FastFlex LED module. In this guide you will find all the information required to design this module into a luminaire as well as valuable hints and tips.

Information and support

On our website at www.philips.com/technology, you will not only find information about this module but also

- Design-in guides
- Datasheets
- Familysheets
- CAD files
- Certificates

of all these Fortimo FastFlex LED products.

If you require any further information or support please consult your local sales representative.

Basics

To operate a system you will need one or more FastFlex LED modules, they might consist of different parts that are sold separately.



Important usage notes

- Please refer to the respective product datasheet for the reference T_{case} and for the maximum T_{case} values. T_{case} must not exceed the provided figure at the given drive current.
- In all cases, the module T_c should be in line with the max. allowed operating temperature specified by the third party lens supplier
- Failure to comply with usage conditions will void product warranty

Each system using any Fortimo FastFlex LED module type consists of:

- a FastFlex LED module
- third party optics
- a compatible LED driver (Please refer to the “Easy design-in tool” on www.easydesignintool.signify.com)

Note: Third party lenses are not included.

Applications

The Fortimo FastFlex LED module has been developed primarily for outdoor and industry lighting applications but can also be used indoor (providing the applicable UL or IEC regulations are observed and all design-in requirements are met).

The FastFlex LED module with Xitanium driver can be used in:

- Class I and Class II IEC isolation systems

Product Range

The Fortimo FastFlex LED modules described in this guide are available in different CCT and CRI versions.

The modules together with a wide range of third party lenses enable the creation of outdoor and industrial LED lighting systems for every type of application.

Fortimo FastFlex LED modules can be divided in 4 main groups, designed to offer a suitable solution to each type of OEM:

- Fortimo FastFlex LED module DA Gx, (U)HE, CR, Night Glow and Color Ambiance (referred to as DA in this document)
- Fortimo FastFlex LED module 2x6 DP Gx, (U)HE, Night Glow and Color Ambiance (referred to as DP in this document)
- Fortimo FastFlex LED module DHE (referred to as DHE in this document)

All Fortimo FastFlex LED modules were designed to operate together with third party lenses, enabling unlimited optical configurations. IP ratings at module level are made possible with the FastFlex DP version for maximum cost effectiveness and fixture efficacy.

Full characteristics of each module is described in respective datasheets which can be found here: https://www.signify.com/global/prof/led-electronics/outdoor-modules/XTRMOD_CA/category

Recommendations

The following recommendations should be taken into account when using FastFlex LED modules and Xitanium LED drivers.



Important usage conditions

- Failure to comply with usage conditions will void product warranty

Design-in phase

- It is recommended to use the approved Philips Xitanium or Advance Xitanium LED drivers. For approved drivers, please refer to the “easy design-in tool” on www.easydesignintool.com
- It is mandatory to design the luminaire so it is enclosed in such a way that it can only be opened with special tools (by an electrician) in order to prevent accidental contact with live parts.
- Safety and IEC recommendations: the general IEC recommendations for luminaire design and national safety regulations (ENEC, CE, etc.) also apply to selected FastFlex LED modules and Xitanium LED drivers. Luminaire manufacturers are advised to conform to the international standards for luminaire design (IEC 60598 - Luminaires).

Design-in and manufacturing phase

- Do not use damaged or defective modules.
- Do not drop the LED module or let any object fall onto it as this may damage the module. Do not use the LED module if it has been dropped or an object has fallen onto it.

Installation and service phase of luminaires

- The luminaire should not be serviced while the mains voltage is connected; this includes connecting or disconnecting the FastFlex LED module wires from the driver.
- Hot wiring is not allowed.

Controllability

Default controlling protocols

The FastFlex LED module is controllable with a range of integrated light control options.

- Adjustable Output Current
- Constant Light Output
- 1-10 V, AmpDim, DALI and Dynadimmer dimming

Specific features will depend on the Xitanium LED driver system selected. Please visit www.signify.com/global/prof/led-electronics/outdoor-drivers/XTRDRV_CA/category for complete information on the integrated light control options available in the Xitanium product range.



Warning

Philips does not specify product performance for modules operating below 100mA .

Controlling FastFlex LED module with Xitanium LED drivers

It is recommended to operate the Fortimo FastFlex in combination with a programmable Xitanium driver. Please refer to the data sheet of the chosen driver to determine how the operating current is set.

Xi FP and Xi LP LED drivers allow the use of several control protocols, including 1-10 V, DALI, Integrated Dynadimmer and CLO. Further details on programming with MultiOne can be found in the Design-in guide for Xitanium Xtreme Drivers. The Design-in guide can be downloaded via our website at www.signify.com/global/prof/led-electronics/outdoor-drivers/XTRDRV_CA/category

Thermal management

This section outlines key thermal considerations when using Fortimo FastFlex LED modules to achieve optimal performance and lifetime of the system.

Thermal specifications

The main thermal specification that needs to be taken into account when designing in the FastFlex LED module is the T_{case} temperature. The T_{case} must never exceed $T_{case,max}$. Please refer to the product datasheet for further details.

Operating temperature

Definitions

- **Module temperature:** temperature measured at the specified T_{case} point of the module
- **Driver temperature:** temperature measured at the specified T_{case} point on the driver
- **Ambient temperature:** temperature of the air surrounding the luminaire in the test environment or application
- **Ambient temperature in a lab environment:** air temperature in a testing area, in a controlled environment free from drafts
- **Average ambient temperature:** monthly average temperature based on at least 2 measurements per day, with at least 8-hour intervals between measurements

Module temperature

To achieve typical product lifetime characteristics, it is crucial to ensure that the product is operating within the specified temperature limits. These limits are determined not only by the product and the application, but also by the luminaire design and ambient environment. Please refer to the performance window in the datasheet.



Warning

- Maximum T_{case} should never exceed specified $T_{case,max}$
- For lifetime warranty T_{case} should not exceed specified $T_{case,life}$.
- Please refer to the specific datasheet for $T_{case,max}$ and $T_{case,life}$ value

Thermal de-rating

The Fortimo FastFlex LED modules DA contain a thermal de-rating system to detect overheating and extreme lifetime degradation of the LEDs when operated outside the maximum permitted environmental conditions. Such conditions can be caused by extreme ambient temperatures or inadequate heat management design. The thermal de-rating is based on temperature detection on the FastFlex LED module. When multiple modules are connected to 1 driver, one module is in the "master" mode and the others are in the "slave" mode. It is strongly recommended that the information is read out from the module with the highest T_{case} in the application.

When the FastFlex LED module is used in combination with Xitanium LED Programmable drivers, the default driver profile will ensure the correct Module Temperature Protection (MTP) settings. For availability of the MTP function on the specific module, please check the datasheet.



Warning

MTP is only a failsafe in order to protect the module against overheating during peaks in ambient temperature or in the event of a faulty heat sink design. Optimum performance will only be achieved when operated in the performance window. Do not forget to enable the MTP function in the driver with MultiOne.

Thermal measurements

The maximum ambient temperature at which the luminaire will operate constitutes the initial key criterion for defining the correct temperature limit and validating the thermal luminaire design.

If the maximum ambient temperature ($T_{amb,max}$) is 25 °C or lower, the luminaire design needs to ensure that the module temperature does not exceed the maximum T_{case} when tested in a lab environment at 25 °C ambient.

Note: The ambient temperatures given above are average temperatures during the operational period of the module.

Critical temperature point (T_{case})

For LEDs, the junction temperature is the critical factor for operation. Since there is a direct relation between the case temperature and the LED junction temperature, it is sufficient to measure the casing of the FastFlex LED module at its critical temperature point, . Please refer to figure (Tc point on FastFlex LED module). If the case temperature at the T_{case} point exceeds the recommended $T_{case,life}$, this will have an adverse effect on the performance of the LEDs and the FastFlex LED module in terms of light output, lifetime and lumen maintenance.

Measurement of critical temperature point

On the top of the module and typically at the center of the module there is a T_{case} (Tc) point, which should be used for all temperature measurements. Please refer to figure in product datasheet. The temperature must be stable before any reliable data can be obtained (depending on the size and material of the luminaire, this will take between 30 and 180 minutes).

It is essential to have a stable connection between the thermocouple and the module. Any shifting of the thermocouple will result in measurement errors and poor measurement repeatability.

Note

In order to ensure reliable T_{case} test results, the case temperature should not vary by more than 1 °C for a period of at least 30 minutes.

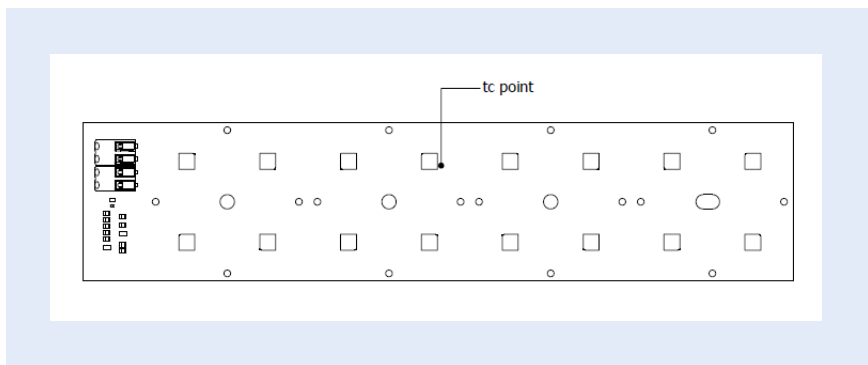

Example of a Tc point on a FastFlex LED module

Critical module temperature with respect to CLO

The FastFlex LED module can sometimes be used with Xitanium Programmable LED drivers with a Constant Light Output (CLO) feature. Over the system lifetime the driver will automatically increase the output current to compensate for lumen depreciation and to keep light levels constant. The thermal design should be done based on the full output current at the end of the CLO profile, to ensure that the T_{case} temperature and drive current do not exceed their maximum ratings at end of life.

Note

- Programming CLO increases the thermal load over the lifetime of the module. Thermal management needs to ensure T_{case} at end-of-life does not exceed the maximum T_{case} of the module. (Please refer to the respective product datasheet)
- CLO current at end-of-life drive current must not exceed maximum specified current. (Please refer to the respective product datasheet)

Heat sink design

The FastFlex LED module is primarily designed for metal luminaires in which the luminaire housing may double as the heat sink. The actual difference between the T_{case} point and the ambient temperature of the surroundings will depend on the heat sink and thermal design of the luminaire.

Heat sink material

The type of material used has a significant influence on the final result. For example, a comparison of the thermal conductivity (k) of copper with that of corrosion-resistant steel - Thermal conductivity shows that a substantially smaller heat sink can be made with copper. The best material for heat sink is (soft) aluminum. The thickness (H) of the heat sink is also of major importance. If identical heat sinks made from different materials were used, a similar effect would be achieved with 1 mm copper, 2 mm aluminum, 4 mm brass, 8 mm steel and 26 mm corrosion-resistant steel.

Thermal conductivity

Material	W/mK
Copper	400
Aluminum	200
Brass	100
Steel	50
Corrosion-resistant steel	15

Thermal radiation and emissivity coefficient

Thermal radiation accounts for a substantial part of the total heat transfer. The amount of thermal radiation is highly dependent on the emissivity coefficient of the surface. For example, a polished aluminum surface has a very low emissivity coefficient, while a painted surface has a very high one. A higher emissivity coefficient means more effective heat transfer.

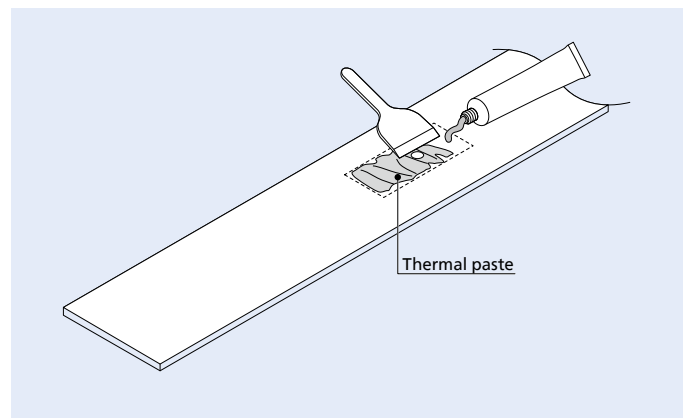

Interface between module and mounting plate filled with thermal paste

Thermal emissivity coefficients of common materials

Material	Finish	Emissivity coefficient
Aluminum	New/polished	0.04 - 0.06
	Blank	0.20 - 0.30
	Anodized	0.80 - 0.95
Steel	New/polished	0.10
	Painted/coated	0.80 - 0.95

Thermal interface

The thermal interface is the interface between the module and the mounting surface in the luminaire. To ensure good thermal contact, it is recommended that the contact area is covered with thermal interface material, e.g. thermal paste.

Alternatives to thermal paste include thermal interface materials (TIM) like graphite pads that can also be utilized to improve the thermal conduction from the LED module to the mounting surface. We recommend the use of thermal paste for MC-PCB. For CEM 3 PCBs, it may not be needed.

Important points for luminaire design

- Ensure good thermal contact between the module/driver and the housing or heatsink to dissipate the heat.
- Place the module(s) and driver at a distance from each other to obtain a more homogeneous temperature distribution in the luminaire.
- When mounting FastFlex LED modules directly on the luminaire housing, we recommend using aluminum that is at least 3 mm thick; thinner material will limit the heat flow through the luminaire housing and thicker material will improve the heat flow through the luminaire housing, resulting in a lower T_{case} of the module.
- Use anodized, painted surfaces rather than blank surfaces in order to increase the transfer of heat via thermal radiation.
- Use highly thermally conductive materials (e.g. aluminum) in the primary heat path.
- Limit the number of thermal interfaces in the primary heat path towards the ambient air.
- Please ensure the lens material can withstand the temperatures in the luminaire

Xitanium LED driver temperature

The next key component is the driver, which influences the lifetime and reliability of the system. It is important to ensure good thermal and electrical contact between the driver and the luminaire as this enables the heat to dissipate efficiently and allows the driver to deliver optimal electrical performance. The driver temperature can be measured with a thermocouple at the T_{case} point, shown on the driver label.

Critical driver temperature point with respect to CLO

When the FastFlex LED module is used with Xitanium Programmable LED drivers, CLO will increase the output current. As a result, the driver losses will increase accordingly, which in turn will lead to a higher driver T_{case} temperature. For the thermal design it is therefore important to ensure that the T_{case} temperature of the driver is within specification for its $T_{case\ max}$ at end of life.

Please refer to individual product datasheets for $T_{case\ max}$ information.

NTC and thermal design

This feature helps to protect the LEDs when they are operated in a hot ambient environment. The thermal design of an LED luminaire should be such that the critical T_c temperature of the module is not reached under normal application conditions.

The purpose of the NTC is to assure the lifetime of the LED module in the event that external thermal influences result in the critical temperature being exceeded. Not all modules have an NTC. For modules without the NTC, the DTL function of the driver can be used to "protect" the module. For more information on the DTL function please refer to the Design-in guide of the Philips Xitanium or Advance LED drivers.



Warning

Not all drivers have the NTC and/or DTL feature, please check on the website at www.lighting.philips.com/prof/led-electronics/xtreme-drivers/XTRDRV_CA/category

FastFlex LED module assembly

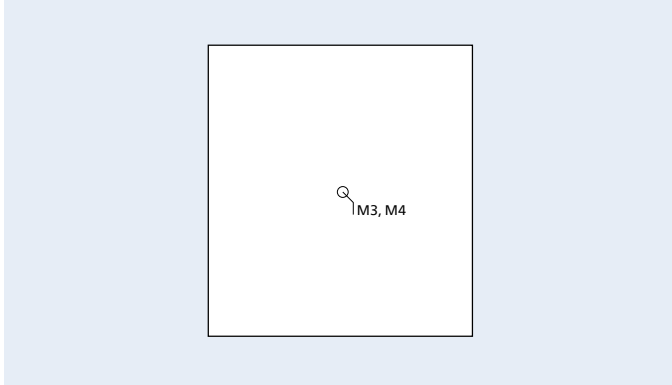

Mounting hole pattern for FastFlex 2x2 DA

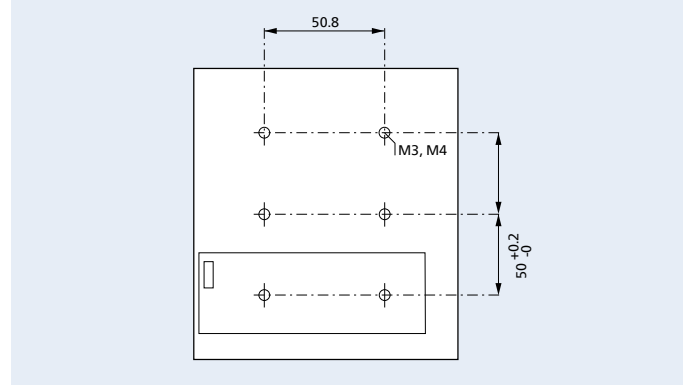

Mounting hole pattern for FastFlex 2x4 DA

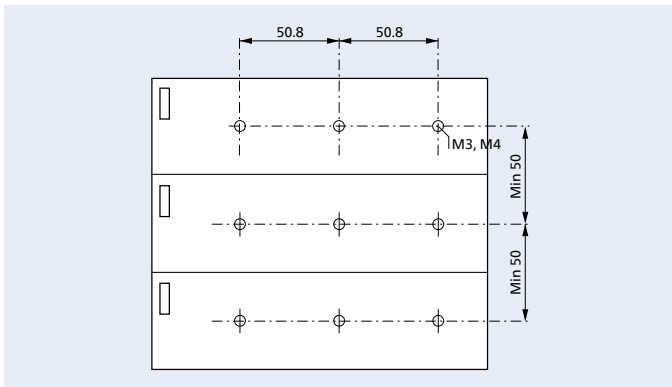

Mounting hole pattern for FastFlex 2x6 DA

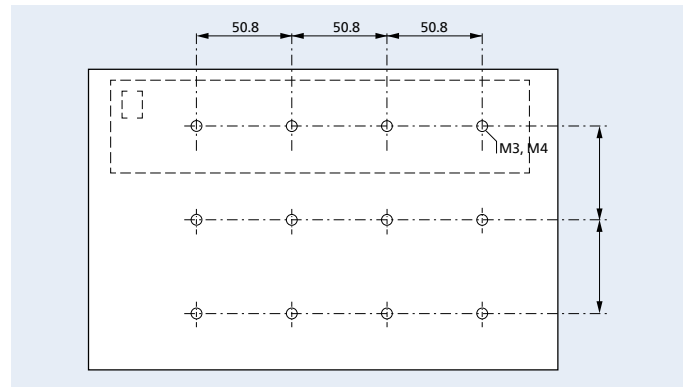

Mounting hole pattern for FastFlex 2x8 DA, DHE

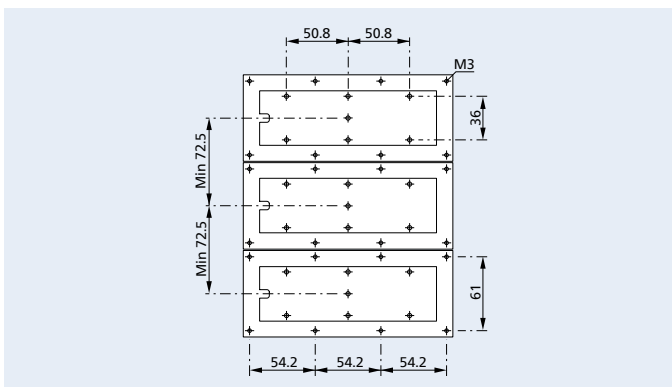

Mounting hole pattern for FastFlex 2x6 DP

Note

- It is advisable to wear gloves during the installation of the lenses in order to prevent any dirt affecting the lenses.
- A dust-free environment is recommended.

Mounting hole pattern

The pattern of the holes (in the luminaire) must be checked and inspected before assembly commences. The drawing supplied describes the hole pattern for each module and also the distance between individual modules. For 2x2 DA modules, a screen can be used to align the module with respect to the fixture.

Note that newest FastFlex DA Night glow and FastFlex Color Ambiance modules only accept M3 screws for mounting but not M4.

It is important to guide the cable between the different modules, so it is out of the light path in order to prevent light losses. Do not allow cables to become tangled, keep them short and guided.

Installation instructions



Warning

The FastFlex LED module/s should always be replaced by an OEM-qualified installer. Special attention should be paid to the following points:

- Do not service the system when the mains voltage is connected; this includes connecting or disconnecting the cable.
- Before a new FastFlex LED module is mounted, the old thermal interface must be removed and the area must be cleaned.

Mechanical fixation

The separate components (driver and module/s) of the FastFlex LED system can be fixed in place securely using the mounting holes located on the module(s) and driver. Please refer to the dimensional drawings for specific details. The 3D CAD files can be downloaded from the Philips Technology website at www.signify.com/oem/en-gb

In a system with multiple modules, it is recommended that the modules are mounted not more than 10mm apart for good appearance.

In the case of the Fortimo FastFlex LED module DA Gx, DP, and DHE, the third party lenses (OEM or complementary partner made) must be installed on the module by means of M3 screws. The screw holes of the Fortimo FastFlex LED module DA (U)HE and DA CR support M3 and M4 screws. Please refer to the lens supplier to define the maximum allowed torque to be applied to the screws.

Fixation of the module

Before fixing the FastFlex LED module, ensure that the mounting surface is clean and flat, without any protrusions or pits. Also, ensure that the electrical connection between the module and the mounting surface is well-defined and not subject to potential intermittent contact due to surface coatings.

To ensure a reliable thermal and mechanical attachment, we recommend that the flatness of the mounting surface should be ≤ 0.2 mm.

For optimum thermal performance, use a thin layer of thermal paste between the module and the mounting surface. The entire bottom surface of the module needs to be covered with thermal paste, with a typical bond line of 30 to 50 microns. Other thermal interface materials can be used but will require more cooling from the luminaire (i.e. more contact surface between the luminaire and the ambient air). For more information see the Thermal management section in this guide.

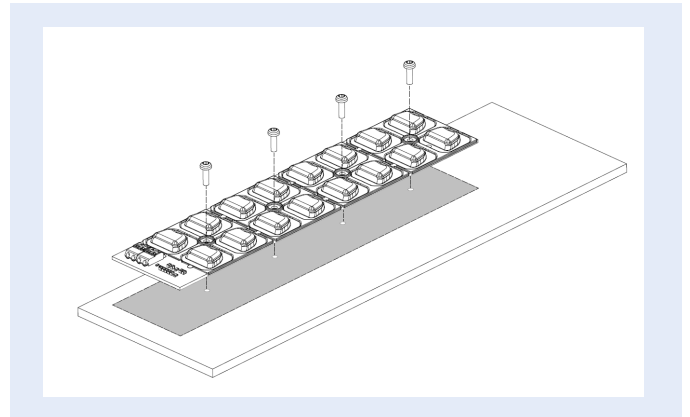

Example of fixation of the FastFlex module.

Fixation of the complete module inside the luminaire

When designing FastFlex LED module into a luminaire, the following should be taken into consideration.

Luminaire glass

The module should be placed as close as possible to the luminaire front glass in order to reduce optical losses and therefore achieve the best possible LOR.

To minimize reflective glare, we recommend that the luminaire glass is positioned 2 mm above the highest point of the module.

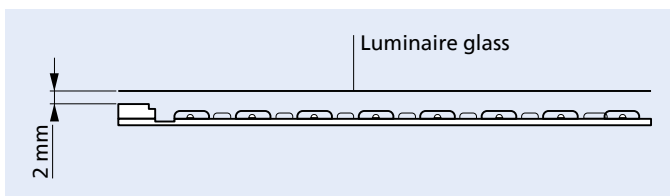

Distance between FastFlex LED module and glass in a luminaire

Fixation of the driver

Please refer to the specific Xitanium LED driver product datasheet and design-in guide for individual product dimensions and installation instructions.

Connection between module and driver

The Fortimo FastFlex has been designed to be connected via standard wiring to the selected driver. Please refer to the module datasheet for recommended wiring specifications.

Warning

- Operating the module above I-life and Tc-life will void the warranty and may damage the LEDs.
- When using the programmable Xitanium drivers the drive current needs to be programmed via the MultiOne configurator.
- Take care not to cause damage to the module when inserting solid wires into the poke-in connectors; sharp edges on the wire core can cause scratches in the isolation material of the module, thereby compromising the insulation performance.
- Signify does not recommend the use of stranded, non-tinned wires, due to the risk of loose strands causing short circuit or compromising the isolation.
- Misswiring can lead to damaged products.

You can find more information on these drivers in the design-in guide at www.signify.com/global/prof/led-electronics/outdoor-drivers/XTRDRV_CA/category



Warning

- If a system consists of multiple FastFlex modules connected to a single driver, only one module is monitored by the NTC
- A robust thermal design is strongly recommended
- Always use modules of the same type and batch

Surge protection in a FastFlex LED system

FastFlex LED modules have a high level of integrated protection against the adverse effects of external surges and electro-static discharges. For optimum system protection, apply external common-mode and differential-mode surge protection at luminaire level in order to mitigate the harmful effects of surges on the LED driver and the FastFlex LED module.

Module replacement

When multiple modules are connected to one driver, one module is in "master" mode and the rest are in "slave" mode. Always connect/replace all modules with products from the same series as LED performance is improving all the time.

If modules with different efficacies are connected to the same driver, it may result in a luminous flux difference between modules.

Using a long cable in combination with the FastFlex LED module system

When using AWG24 cables, the connection between module(s) and driver can be extended by up to 10 meters without affecting the power supply to the module. It is not advisable to use the communication wires (NTC- Common) because of possible interference. Also check the remote mounting guidelines in the design-in guide of the driver.

In case of questions please request Design-in support via your local Signify sales representative.



Warning

When using a long cable between the module and driver, extra care should be taken in the design of EMI, surge and noise suppression. It is also important to ensure the cable is guided out of the optical path.

Luminaire isolation Class I and Class II applications

FastFlex LED modules are suitable for luminaire isolation Class I and Class II applications in combination with approved Philips Xitanium LED drivers. Approved combinations (please refer to the Easy design-in tool) comply with the latest IEC60598 luminaire standard requirements.

Wiring

Specification item	Value	Unit	Condition
Input wire cross-section	0.25...0.75	mm ²	solid wire
	18...24	AWG	solid wire
Input wire strip length	7.5...8.5	mm	
Input wire cross-section	0.33...0.5	mm ²	stranded wire
	20...22	AWG	stranded wire
Input wire strip length	7.5...8.5	mm	

Connection with NTC

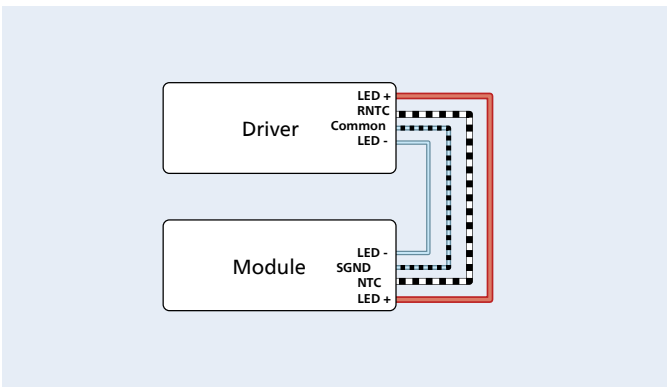

Example of connecting a Xitanium driver with a FastFlex DA LED module. Connection of NTC is optional.

series

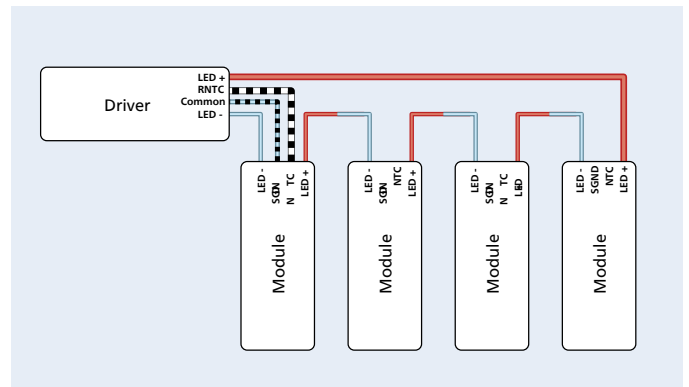

Example of connecting a Xitanium driver with multiple FastFlex DA LED modules. Connection of NTC is optional.

Connection without NTC

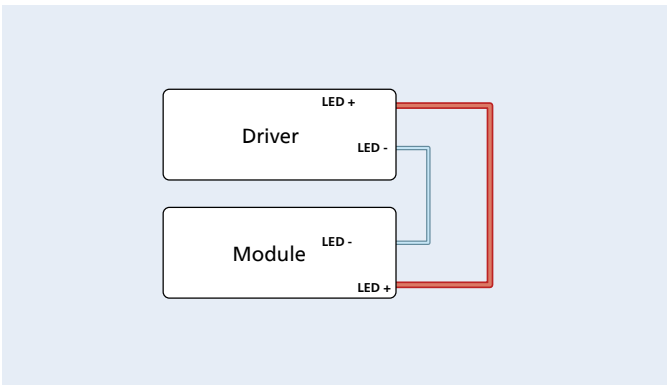

Example of connecting a Xitanium driver with a FastFlex DP or DHE LED module

series

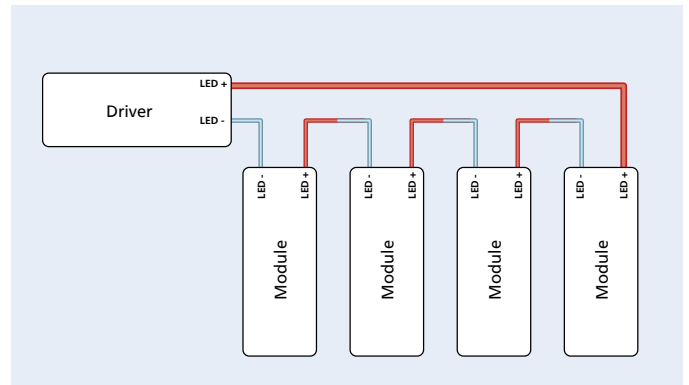

Example of connecting a Xitanium driver with multiple FastFlex DP or DHE LED modules

Quality

Compliance and approval marks

The FastFlex LED module is ENEC approved and complies with the applicable EU directives.

To ensure approval of the luminaire, the conditions of acceptance need to be fulfilled. Module-related data can be found in IEC 62031 and UL8750. All luminaire manufacturers are advised to conform to the international standards of luminaire design (IEC 60598 or UL1598).

Complementary partners

LEDIL www.ledil.com

BJB www.bjb.com

Gaggione www.optic-gaggione.com

Carclo www.carclo-optics.com

Darkoo Optics www.darkoo.cc

Kathod www.kathod.com

Most lenses are made of PMMA because of best transmission, in case of extreme thermal condition lenses of PC and silicone can be used. These lenses can stand higher temperatures.

Sustainability

FastFlex LED modules are compliant with European Directive 2011/65/EU, recasting 2002/95/EC on Restriction of the Use of Certain Hazardous Substances in Electrical and Electronic Equipment (RoHS). The modules comply with Reach, as defined by the EU Chemical Agency.

Warranty

The warranty on FastFlex LED module performance only applies if the product is used in combination with approved Philips Xitanium LED drivers. Please refer to the Easy design-in tool.

IP rating, humidity and condensation

FastFlex systems are build-in systems and therefore have no IP classification. They are not designed for operation in the open air. The OEM is responsible for proper IP classification and approbation of the luminaire.

FastFlex LED modules are not suitable for direct exposure to moisture, dust, chemicals, salt, etc.

In the case of the FastFlex DP and DHE the protection against external agents can be achieved by the installation of the module in combination with a third party IP ready lens.



Warning

FastFlex LED module has been developed and released for use in dry and damp locations and not for locations where condensation is present. If there is a possibility that condensation could come into contact with the modules, the system/luminaire builder must take precautions to prevent this.

Photobiological safety

The photobiological safety standard IEC 62471 (Photobiological safety of lamps and lamp systems) gives guidance on the evaluation of the photobiological safety of lamps and lamp systems, including luminaires. This standard specifies the exposure limits, reference measurement technique and classification scheme. It should be used for the evaluation and control of photobiological hazards from all electrically powered, incoherent broadband sources of optical radiation, including LEDs, in the wavelength range from 200 to 3000 nm.

Wavelengths used for photobiological safety measurements

Radiance-based

Measurement	Symbol	Wavelength Range
Blue Light	LB	300 - 700 nm
Retinal Thermal	LR	380 - 1400 nm
Retinal Thermal	LIR	780 - 1400 nm

Irradiance-based

Measurement	Symbol	Wavelength Range
Actinic UV Skin & Eye	E _s	200 - 400 nm
Eye UVA	E _{UVA}	200 - 400 nm
Blue Light Small Sources	E _B	300 - 700 nm
Eye IR	E _{IR}	780 - 3000 nm

Measured results of emission limits for FastFlex LED modules using the non-GLS (20cm) method are available on request via your local sales department.

FastFlex photobiological measurement results

Item	Symbol	Result: Risk group
Actinic UV	E _s	Exempt
Near-UV	E _{UVA}	Exempt
Retinal Blue Light	L _B	RG1/RG2 threshold distance depending on color temperature and type of lenses
Retinal thermal	L _r	Exempt
Infrared eye	E _{IR}	Exempt

Conclusion regarding photobiological safety

All type of modules (CCT) are measured and information is available on request via your local sales department. Assembly (including optics and front glass) in the luminaire can improve the level of photobiological safety.

EMC

Electromagnetic compatibility, EMC, is the ability of a device or system to operate satisfactorily in its electromagnetic environment without causing unacceptable interference in practical situations. In general, LED modules have no effect on the EMC of a luminaire. The FastFlex was tested with a Xitanium driver in a reference luminaire and no EMC issues were observed.

Electrostatic discharge (ESD)

Introduction to ESD

It is generally recognized that Electro Static Discharge (ESD) can damage electronic components, like LED chips, resulting in early failures. Appropriate ESD protection measures should be exercised when assembling and servicing LED luminaires.

ESD in the manufacturing or assembly environment

Depending on the immunity level of the LED module, there is a minimum set of measures that have to be implemented when handling LED modules. ESD measures are required in a production environment where handling can exceed the ESD immunity level. Furthermore, products that are susceptible to ESD must be packed and delivered in ESD-safe packaging.

The purpose of an effective ESD-control strategy is to reduce line failures, final inspection failures and field failures.

ESD specifications

Philips designed FastFlex LED module products to be robust when exposed to ESD.

The maximum permitted contact discharge level and air discharge level, according to IEC 61000-4-2 (HBM 150 pF + 330 Ω), is 8 kV contact and 15 kV air.

Servicing and installing luminaires

It is highly recommended that installers are instructed not to touch the LEDs and to use earthed arm straps to prevent ESD damage during installation and maintenance.

ESD consultancy

Independent ESD consultancy companies can advise and supply adequate tools and protection guidance.

Remote system operation

Please consult the design-in guide for Xitanium LED drivers.

Note on conditions: storage, transportation & operation

- Store in a dark place
- Do not expose to sunlight
- Maintain temperature between -30 and +60 °C
- Relative humidity (RH) between 5% and 85%

During operation

FastFlex modules must be operated within the specifications stated in the product data sheet and design-in guide. Please contact your local sales representative for additional information.

System disposal

We recommend that the FastFlex LED module and its components are disposed of in an appropriate way at the end of their (economic) lifetime. The modules are in effect normal pieces of electronic equipment containing components that are currently not considered to be harmful to the environment. We therefore recommend that these parts are disposed of as normal electronic waste, in accordance with local regulations.

Disclaimer

Philips will perform the testing of the LED systems to high standards of workmanship. The tests are carried out with reference to the EN/IEC standards, if any, which are regarded by Philips as being of major importance for the application of the lamp gear and the lamp within the fixture for horticultural applications.

The design-in guide, regarding the testing and design in of the LED system provided by Philips, is not an official testing certificate, and cannot be regarded as a document for official release of the fixture. The OEM is liable for the official testing by a certified test body and all markings, such as CE and ENEC marks, on the fixture assembly.

The design-in guide is for information purposes only and may contain recommendations for detecting weak points in the design of the system (lamp – lamp gear – fixture), if any.

Specifically mentioned materials and/or tools from third parties are only indicative: other equivalent equipment may be used but it is recommended that you contact Philips for verification.

Philips will not be liable for unforeseen interactions of the proposed solutions when applied in the fixtures or applications using these fixtures. Philips has not investigated whether the recommendations are or will in the future be in conflict with existing patents or any other intellectual property right. Philips does not warrant that its recommendations are technically or commercially the best options.

Since the tests are only performed on one particular fixture provided by the customer, it will be treated as a prototype. This means that there is no statistical evidence regarding later production quality and performance of the lamp – lamp gear – fixture system.

As Philips does not have control over manufacturing of the fixtures, Philips cannot be held liable for the fixture assembly.

Philips will not accept claims for any damage caused by implementing the recommendations.

No warranty whatsoever may be claimed by the OEM with regard to the content and/or quality of the design-in guide or any other advice, or the conclusions and/or recommendations in the design-in guide or any other document, either express or implied, and Philips expressly disclaims any implied warranties of any kind, including without limitation any warranties of satisfactory quality, fitness for a particular purpose or non-infringement and any warranties regarding the design-in guide or any other advice or the use of the results of any activity performed while testing the fixture with respect to its correctness, quality, accuracy, completeness, reliability, performance or otherwise.

The OEM expressly agrees that test design-in guides are provided by Philips on an 'as is' basis and an 'as available' basis at customer's sole risk and expense. Philips shall not be liable for any lost profits or lost savings, indirect, incidental, punitive, special, or consequential damages whether or not such damages are based on tort, warranty, contract, or any other legal theory – even if Philips has been advised, or is aware, of the possibility of such damages.

The OEM must bring any claim for damages within ninety (90) days of the day of the event giving rise to any such claim, and all lawsuits relative to any such claim.



© 2026 Signify Holding. IBRS 10461, 5600 VB, NL. All rights reserved. The information provided herein is subject to change, without notice. Signify does not give any representation or warranty as to the accuracy or completeness of the information included herein and shall not be liable for any action in reliance thereon. The information presented in this document is not intended as any commercial offer and does not form part of any quotation or contract, unless otherwise agreed by Signify. Philips and the Philips Shield Emblem are registered trademarks of Koninklijke Philips N.V. All other trademarks are owned by Signify Holding or their respective owners

www.signify.com/oem/en-gb

03/2026
Data subject to change.