



Sinusoidal (Sine Wave) Output
400 VA Output Power Maximum
Automatic Code-Compliant Testing
Reduced Enclosure Size

Product order number:
ELIS400CEC

12 NC number:
913702493601

Project: _____
Location: _____
Cat.No: _____
Type: _____
Qty: _____
Notes: _____

Specifications

UL Listed for Installation in US
Listed to UL 924 for Field Installation
(Indoor and Damp)

California Title 20
Input CEC Title 20 Compliant

Maximum Output Power
400 VA

Maximum Connected Load Power
400 W

Illumination Time
90 Minutes

AC Input Voltage
120 VAC, 60 Hz or 277 VAC, 60 Hz

AC Input Current, (battery charging)
1000 mA Max, 120Vac or
360 mA Max, 277Vac

Battery (4 ea. required)
12V (nominal), 21Ah
Maintenance-Free Sealed Lead Acid Battery

Recharge Time
24 Hours

Charging Indicator Light / Test Switch
Integrated LED Test Switch

Output Voltage, Automatically Selected
120 VAC +/- 10%, or 277 VAC +/- 10%

Output Frequency
60 Hz, ± 5%

Transfer Time
500 ms (approx.)

Loads Operated
LED (per NEMA 10410, formerly NEMA 410)
Fluorescent
Incandescent

Temperature Rating (Ambient)
68° F to 86° F (20° C to 30° C)

Dimensions
12.0" H x 12.5" W x 10.0" D
(317mm x 305mm x 254mm)

Weight
Enclosure and Electronics only: 16 lbs. (7.26 kg)
Batteries: 14 lb. ea. (6.3 kg)
Batteries total: 56 lb. (25.3 kg)

Warranty
Electronics: 1 year full
Battery: 1 year full plus 4 years pro rata

Included
Box 1 – Enclosure with control board assembly and installation kit (mounting hardware, fittings, and site wiring not included)
Box 2 & 3 – Batteries (x4, 2/box), packaged separately



Benefits

- Automatic output voltage select
- Automatic code-compliant testing
- Automatic load monitoring after commissioning (new UL 924 requirement)
- Meets CEC Title 20 (California Energy Commission) efficiency standards.
- Works with LED, fluorescent and incandescent fixtures
- Ideal for (but not limited to) screw-base LED lamps
- Compatible with AC (line voltage) driven TLED lamps
- Remote-mounting up to 1,000 feet maximum

Dimensions

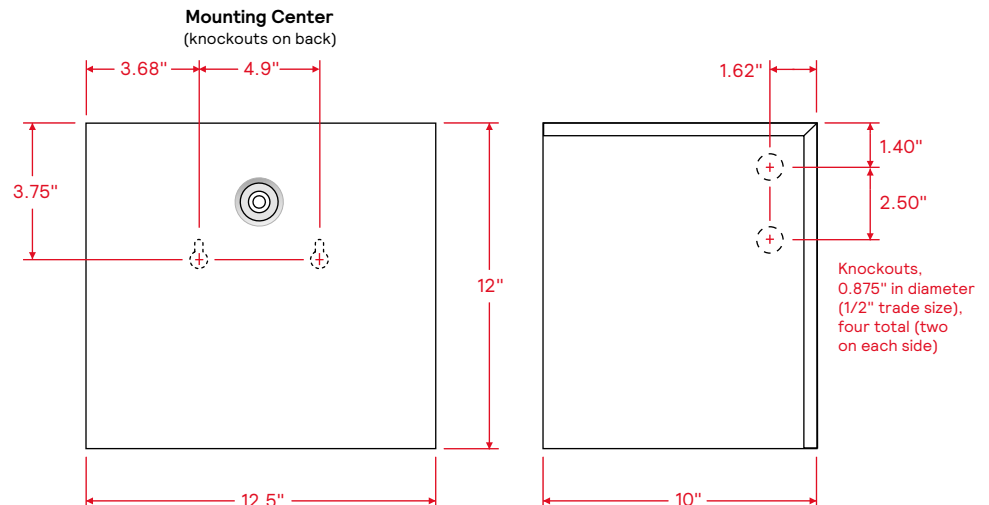

ELI-S-400

Sinusoidal emergency backup inverter

Application

The Bodine ELI-S-400 Emergency Lighting Inverter works in conjunction with fluorescent, LED, or incandescent fixtures to create an emergency lighting system. The ELI-S-400 operates at a maximum output power of 400 VA. It allows the connected fixture(s) to be on, off, switched or dimmed without affecting emergency operation. Each unit consists of four sealed lead acid batteries, charger and electronic circuitry in one steel case. The ELI-S-400 provides power to the input side of the fixture, including the AC ballast/driver, and can be used with indoor or outdoor emergency fixture applications. The ELI-S-400 is NOT suitable for use with HID lighting nor is it rated for outdoor mounting locations.

Operation

Upon failure of normal power, the ELI-S-400 begins providing emergency power to the connected lighting load for a minimum of 90 minutes. A low voltage disconnect circuit protects the inverter batteries from damage by deep discharge during prolonged power failures. When normal power is restored, the ELI-S-400 automatically returns to charge mode. The battery capacity is fully restored in 24 hours. During automated testing, the ELI-S-400 simulates an AC power outage. This causes the inverter to switch to emergency mode and conduct a discharge test to monitor battery voltage and load operation. If the ELI-S-400 detects a problem, the status indicator light flashes. When testing is complete, the ELI-S-400 returns to the charging mode. Automatic testing is conducted for 30 seconds once a month and 90 minutes once a year.

Installation

The ELI-S-400 does not affect normal fixture operation and may be used with a switched or unswitched fixture. It can be installed in close proximity to the fixture or remote from the fixture (using suitable wiring).

Commissioning

Commissioning the ELI-S-400 requires initial calibration as part of the full product installation in order to accurately monitor the load for changes (new UL 924 requirement). See installation instructions for details.

Specification

Emergency lighting shall be provided by using a standard fixture or group of fixtures powered with a Bodine ELI-S-400 self-testing/self-diagnostic emergency lighting inverter. Electronic circuitry shall be self-testing in design and automatically test emergency lighting for a minimum of 30 seconds every 28 days and 90 minutes once a year. Each ELI-S-400 unit consists of four maintenance-free lithium-ion batteries, and electronic battery charging and output generation circuitry contained in one 12.0"H x 12.5"W x 10.0"D metal case. The ELI-S-400 unit shall be capable of powering any combination of fluorescent and/or LED lighting fixtures rated at a total of up to 400W input power at 20°C to 30°C for a minimum of 90 minutes at an output power of 400VA during emergency operation, regardless of local switch or dimmer position. The ELI-S-400 shall allow the connected fixture(s) to be on, off, switched or dimmed without affecting emergency operation. The ELI-S-400 unit shall exceed emergency standards set forth by the current NEC. This device complies with Part 15 of the FCC Rules and meets CEC Title 20

(California Energy Commission) efficiency standards. It shall be UL Listed, suitable for damp locations, and warranted for five years from date of manufacturing.

Emergency Illumination

The ELI-S-400 supports 400 VA of emergency power for a minimum of 90 minutes.

Code Compliance

The ELI-S-400 has been tested by Underwriters Laboratories in accordance with the standards set forth in UL 924, "Emergency Lighting and Power Equipment". The ELI-S-400 is UL Listed for field installation. Emergency illumination time exceeds the National Electrical Code (NEC), Life Safety Code (NFPA-LSC), and UL 90-minute requirements.

Warranty

Model ELI-S-400 is warranted for one (1) full year from the date of manufacture. This warranty excludes the batteries, which have a warranty of one (1) year full plus four (4) additional years pro rata. This warranty covers only properly installed Bodine emergency inverters used under normal conditions. For the warranty period, Bodine will, at its option, repair or replace without charge a defective inverter, provided it is returned to the factory transportation prepaid and our inspection determines it to be defective under terms of the warranty. Repair or replacement, as stated above, shall constitute the purchaser's exclusive warranty, which does not extend to transportation, installation, labor or any other charges; nor does it apply to any equipment of another manufacturer used in conjunction with the inverter.



ELI-S-400

Sinusoidal emergency backup inverter

Schematic

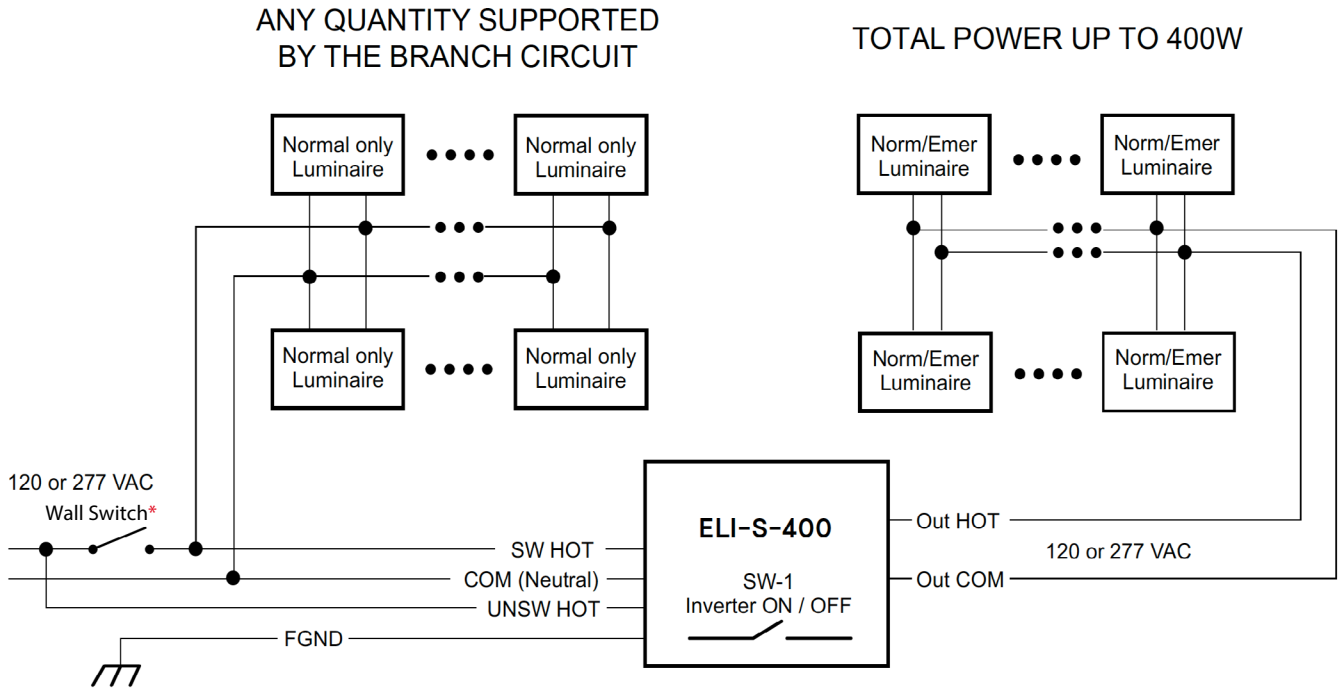

* All connected fixtures must be fed from the same branch circuit and controlled by a single switch or switching means.

Replacement Parts

Batteries	Installation Kit	Battery Harness
PRT00401 Two batteries per box, two boxes required for replacement	PRT00143 Fixture warning labels, ground wires, chokes, and speed nuts and bolts to secure lid	PRT00144 Harness to wire two batteries in series, two required for replacement

a  signify brand

© 2026 Signify Holding. All rights reserved. The information provided herein is subject to change, without notice. Signify does not give any representation or warranty as to the accuracy or completeness of the information included herein and shall not be liable for any action in reliance thereon. The information presented in this document is not intended as any commercial offer and does not form part of any quotation or contract, unless otherwise agreed by Signify.

Signify North America Corporation
 400 Crossing Blvd, Suite 600
 Bridgewater, NJ 08807
 Telephone: 855-486-2216

Signify Canada Ltd.
 281 Hillmount Road,
 Markham, ON, Canada L6C 2S3
 Telephone: 800-668-9008

All trademarks are owned by Signify Holding or their respective owners.