



Contents

Introduction to this guide

Thank you for choosing the Signify MCtoDALI Bridge. This document provides necessary information to design in this product into a luminaire and configure it to suit specific applications. This design-in guide covers radio functionality, mechanical mounting, wiring details, application notes and frequently asked questions. For product specifications, please see the datasheet.

More information or support

For more information or support, please consult your local Philips sales representative or visit:

<https://www.lighting.philips.co.uk/oem-emea/products/connected-lighting/masterconnect>

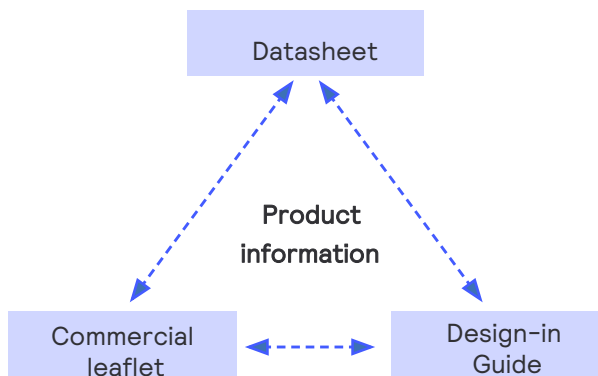

Contents

- 01 **Introduction to this guide**
More information or support
- 02 **Warnings and instructions**
- 03 **Introduction to MCtoDALIBridge**
- 04 **Mechanical design-in**
How to install the MCtoDALI Bridge
Strain relief
Cable preparation
Using the installer code labels
- 07 **Wiring**
Basic wiring to DALI driver
- 08 **Wiring diagrams for MC Emergency**
Maintained emergency setup, DALI dimmable
Maintained emergency setup, non-dimmable
Non-maintained, separate emergency light (3rd party product) - setup
- 10 **Other**
Recommendations to design-in MCtoDALI Bridge with good RF signal
Integration of MCtoDALI Bridge in metal housing luminaires
Design-in recommendation for EMC
MCtoDALI Bridge with multiple LED drivers (1:N application)
- 12 **Disclaimer**

Warnings and instructions

- The MCtoDALI Bridge is connected to mains voltage.
- Avoid touching live parts!
- Do not use damaged products!
- Do not use the product with damaged wires!
- Do not service the product when the mains voltage is connected!
- The MCtoDALI Bridge connects DALI drivers to the Signify's MasterConnect system for wireless communication.
- Do NOT connect D4i or SR drivers (e.g. Xitanium SR sensor ready drivers) to the MCtoDALI Bridge. Do NOT connect another DALI power supply unit to the MCtoDALI Bridge.
- The product has no protection against aggressive chemicals.
- The product is for indoor use.
- Make sure that there is no metal close to a side of the product (<10mm). The MCtoDALI Bridge can be mounted on a metal surface, but metal objects next to the antenna compromise RF communication.

Introduction of MCtoDALI Bridge



MCtoDALI Bridge

The MCtoDALI Bridge connects DALI drivers to Signify's MasterConnect system for wireless communication.

The MCtoDALI Bridge is part of the MasterConnect emergency lighting test monitoring system consisting of luminaires with DALI LED and emergency drivers, MCtoDALI Bridge and Signify MasterConnect gateway. The system enables wireless automated testing and reporting.

Although emergency systems are the main application, the MCtoDALI Bridge is not exclusively for such systems but a general interface between DALI drivers and MasterConnect systems for wireless communication.

The bridge is commissioned and configured via Bluetooth available on modern smartphones using the Philips MasterConnect app.

Mechanical design-in

How to install the MCtoDALI Bridge

The MCtoDALI Bridge can be fixed in the luminaire housing or on a gear tray using two M4 screws. Recommended torque for fixation: 1.2 Nm.

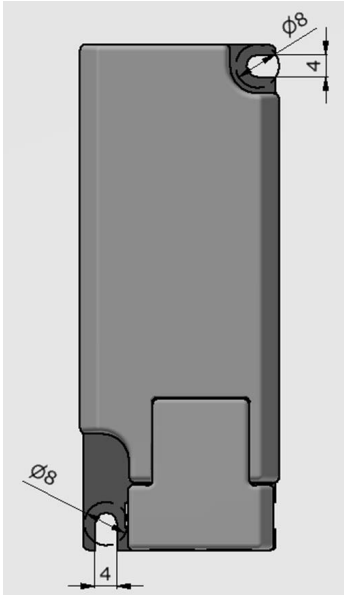

Screw holes for mounting

The MCtoDALI Bridge with strain relief caps can also be used independently, for example on top of a recessed ceiling. The product fits through a 40 mm hole in the recessed ceiling.

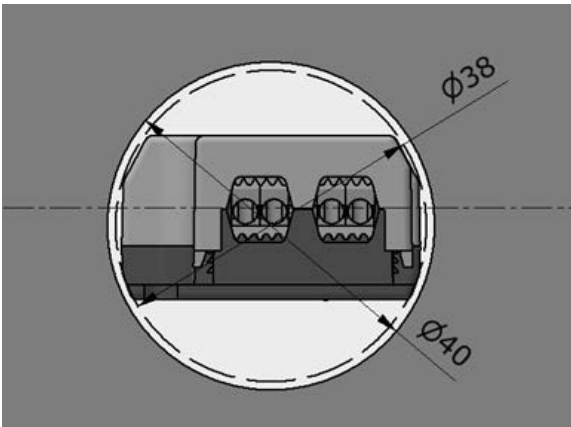

Required opening in recessed ceiling

Mechanical design-in

Strain relief

The strain relief caps can clamp:

Round cables with a diameter between 5 mm and 8,6 mm, and with wires from 2x 0.75 mm² to 3x 1.5mm².

Flat cables with height between 3.1 mm to 4.5 mm and width up to 9 mm, and with wires from 2x 0.75 mm² to 2x 1.5mm² plus 1x 1 mm².

For thicker cables a connector block is needed when the MCtoDALI Bridge is integrated in a luminaire, and a thinner cable in combination with a junction box in case of independent installation. The two cables for mains connection and for DALI must be of same size and shape. Always use two cables.

Make sure that the strain relief cap snaps in when pressing it over the cables. The cap must be on-level or lower than the housing. If it sticks out it needs to be pressed down further, see images.

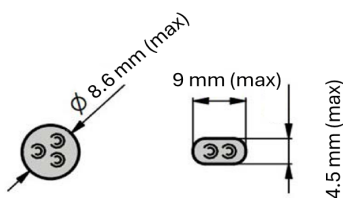

Correct placement strain relief cap

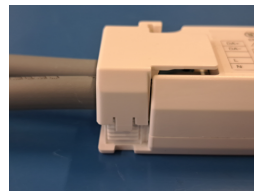

Not correct

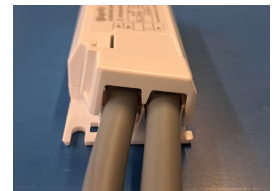

Not correct

Cable preparation



Solid wires: 0.75-1.5 mm²
Stranded wires: 0.75 - 1 mm², only with ferrule
Wire isolation: max diameter 3 mm
Strip length 9 mm ± 0.5 mm

Solid copper, 9mm strip length

In case the installation cable is with 3 wires but the PE wire is not connected, don't cut off the PE wire fully but keep the 6mm part with insulation and bend the wire upwards. That part is needed to avoid that the PE wire can be pulled out of the part of the cable that is squeezed in the strain relief.

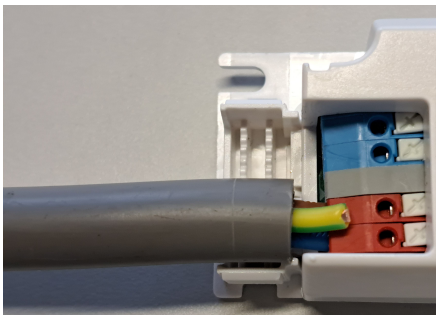

Mechanical design-in

Using the installer code labels

Three labels with the ZigBee Mac address of the MCtoDALI Bridge are attached to the product. The labels can be used to mark the location of lights on a floorplan. The last 4 digits of the ZigBee Mac address are also shown in the MasterConnect app.

1. One label should be placed on the product or close to it
2. The second label can be put on the luminaire
3. The third label can be used for the floorplan



Labels with unique Zigbee Mac address

Wiring

Basic wiring to DALI driver

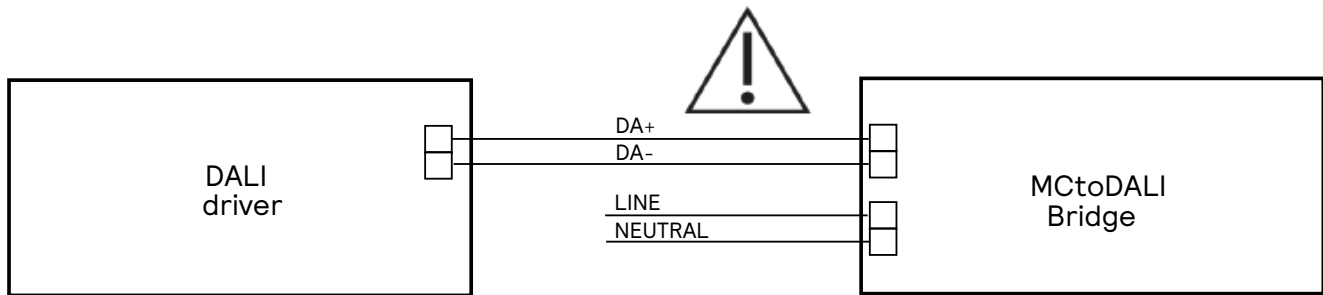

Warning:

Control terminals marked 'Caution' are considered to be hazardous/live parts and are not safe to touch. Circuits connected to these terminals shall be insulated according to the mains supply voltage of the control gear and any terminals connected to these circuits shall be protected against accident contact.

Do not connect D4i or SR drivers (e.g. Xitanium SR sensor ready drivers) or auxiliary DALI power supply to the DALI connection of the MCtoDALI Bridge, as this may cause damage to the device.

Wiring diagrams for MC Emergency

Maintained emergency setup, DALI dimmable

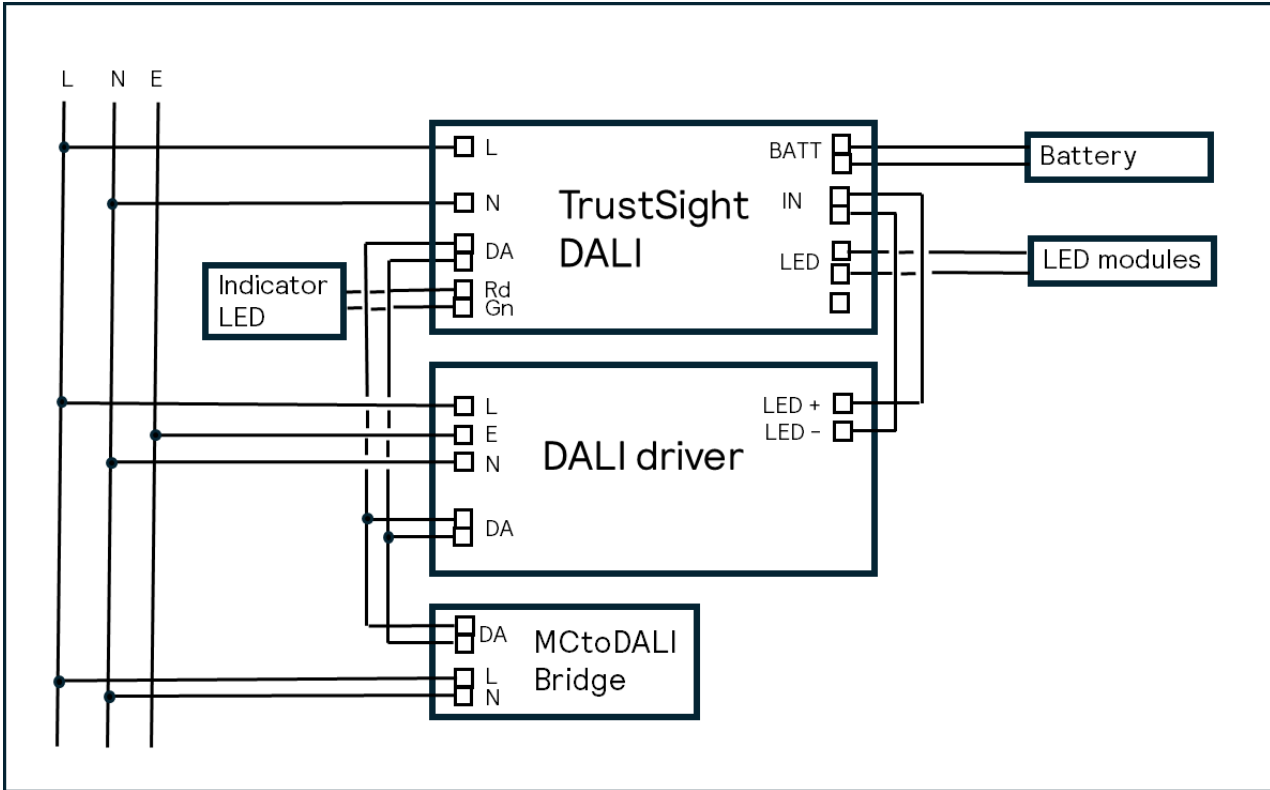

Maintained emergency setup, non-dimmable

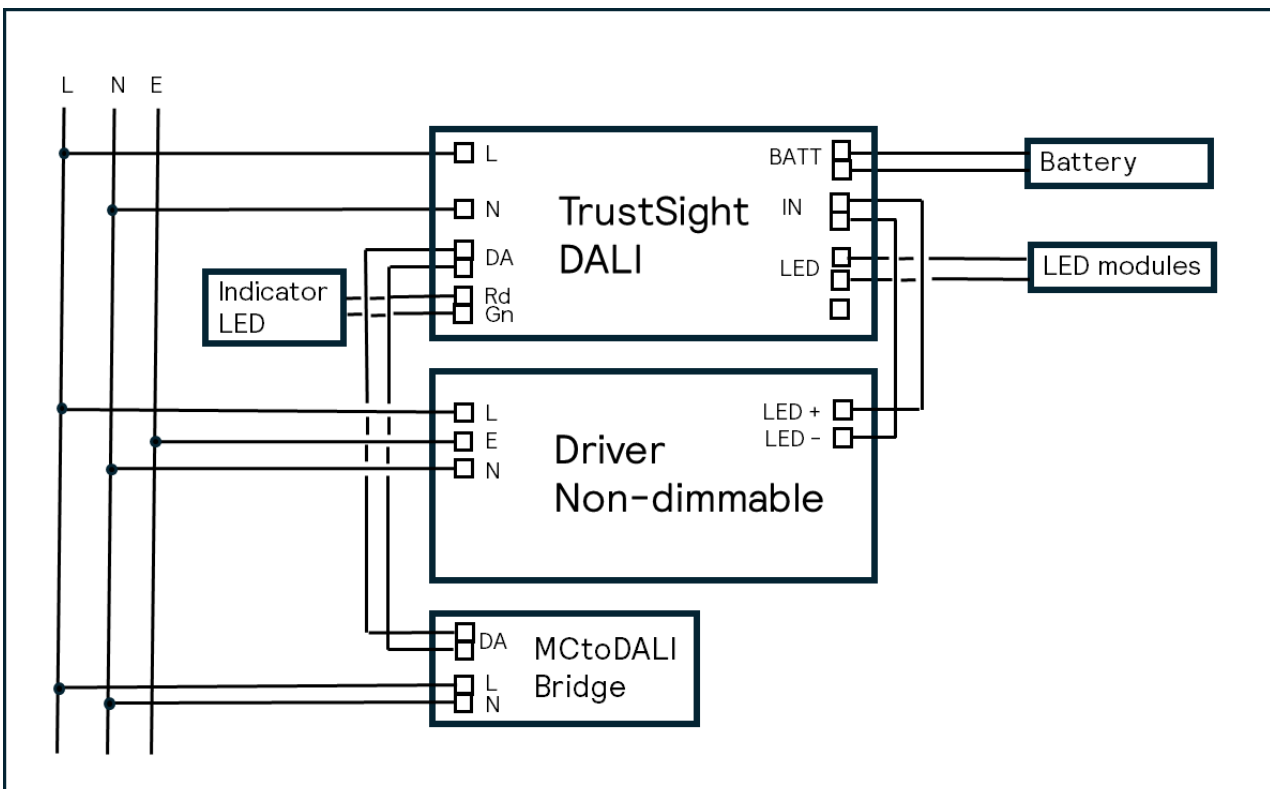

Wiring diagrams for MC Emergency

Non-maintained, separate emergency light (3rd party product) – setup

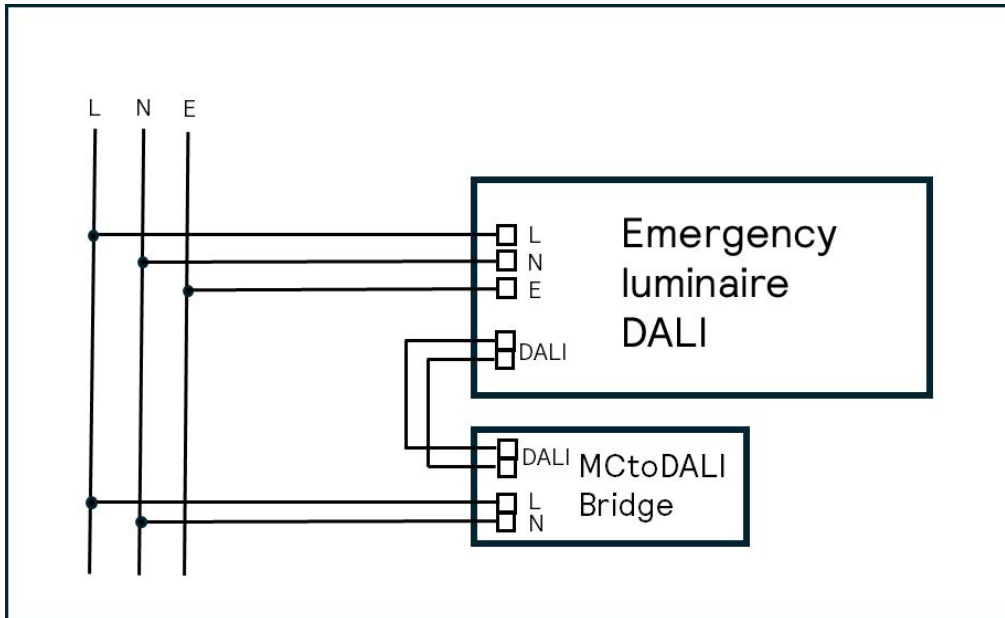

TrustSight emergency system added in wireless MC luminaire

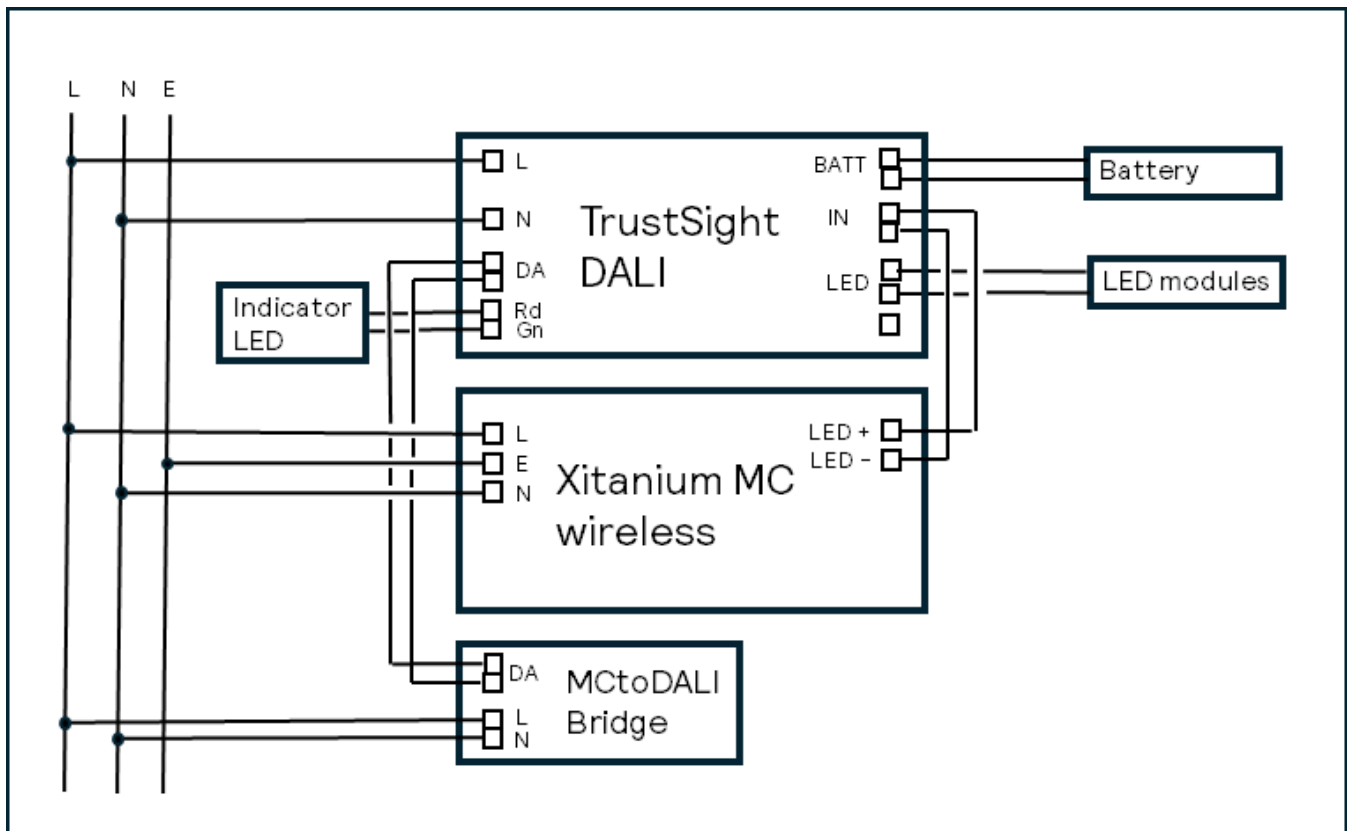

Other

Recommendations to design-in MCtoDALI Bridge with good RF signal

The area next to the antenna must be free from any metal parts in a range of at least 10 mm. It is recommended to keep the MCtoDALI Bridge antenna at a distance >100mm from nearest metal side wall to avoid a drop of RF signals. It is assumed that other side walls are further away. The MCtoDALI Bridge is designed for mounting on metal surfaces, but at the sides of the product metal objects can impact radio performance.

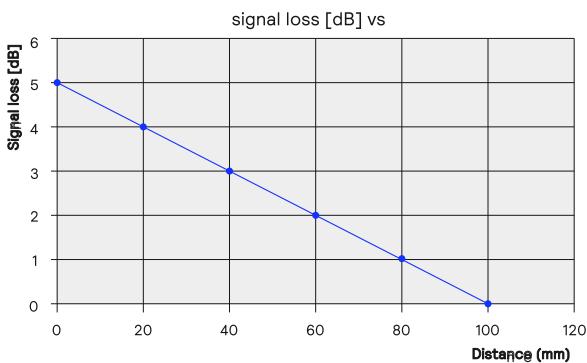

Transmission signal loss [dB] with distance to metal side wall [mm]. The closer the metal wall, higher the signal loss.



The precise antenna position is indicated on the product label.

Integration of MCtoDALI Bridge in metal housing luminaires



Metal housings generally attenuate radio signals significantly and may result in bad radio performance. When releasing the MCtoDALI Bridge in these luminaires a Total Radiated Power (TRP) measurement is recommended. Release limit should be > -7dBm.

General measures which may improve the radio performance for these luminaires are:

- Apply a set of two slots in the luminaire and place the MCtoDALI Bridge in such a position that the radio antenna is facing these slots. The slots do not need to be covered from electrical safety point of view. See the drawing on the left for more details.

- Apply a round or rectangular hole covered with plastic and place the radio-equipped driver in such a position that the radio antenna is close to this (covered) hole. For the hole to be effective the largest dimension should be at least 20mm.

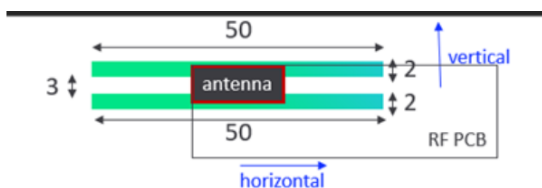

- Recommended dimensions of the two antenna slots:
- 2.0mm (± 0.2 mm) x 50mm (± 5 mm).
 - two slots parallel with 3.0mm (± 0.2 mm) inbetween distance

Other

Design-in recommendation for EMC

In insulation class II luminaires do not connect a protective earth wire to the driver as that might compromise EMC performance.

MCtoDALI Bridge with multiple LED drivers (1:N application)

For emergency lighting test monitoring only 1 DALI driver should be connected to each MCtoDALI Bridge, next to a TrustSight driver.

For other use cases, the MCtoDALI Bridge can be connected to up to 4 DALI drivers that support DALI part 252 - Energy Reporting, in a single luminaire or connected to multiple luminaires. Energy reporting returns the sum of the energy consumed by all connected drivers, but not the individual consumption.

Commands to the connected drivers go to all of them (using DALI broadcast command); it is not possible to address individual drivers.

MCtoDALI Bridge

MasterConnect

Disclaimer

©2026 Signify Holding B.V. All rights reserved.

Note that the information provided in this document is subject to change.

This document is not an official testing certificate and cannot be used or construed as a document authorizing or otherwise supporting an official release of a luminaire. The user of this document remains at all times liable and responsible for any and all required testing and approbation prior to the manufacture and sale of any luminaire.

The recommendations and other advice contained in this document, are provided solely for informational purposes for internal evaluation by the user of this document. Signify does not make and hereby expressly disclaims any warranties or assurances whatsoever as to the accuracy, completeness, reliability, content and/or quality of any recommendations and other advice contained in this document, whether express or implied including, without limitation, any warranties of satisfactory quality, fitness for a particular purpose or noninfringement. Signify has not investigated, and is under no obligation or duty to investigate, whether the recommendations and other advice contained in this document are, or may be, in conflict with existing patents or any other intellectual property rights. The recommendations and other advice contained herein are provided by Signify on an “as is” basis, at the user’s sole risk and expense.

Specifically mentioned products, materials and/or tools from third parties are only indicative and reference to these products, materials and/or tools does not necessarily mean they are endorsed by Signify. Signify gives no warranties regarding these and assumes no legal liability or responsibility for any loss or damage resulting from the use of the information thereto given here.

03/2026
Data subject to
change