

# PD-232N

RS-232 PC Node

Serial port connection node

The Philips Dynalite PD-232N is a network gateway that provides passive integration to a PC or RS-232 system.

# PD-232N

## Serial port connection node

- **Full duplex integration** – Useful for linking a Philips Dynalite system with an AV or HVAC system that supports passive RS-232.

- **Versatile mounting** – Robust housing includes cable tie attachment points for easy installation onto server racks or other IT infrastructure.

## Dimensions

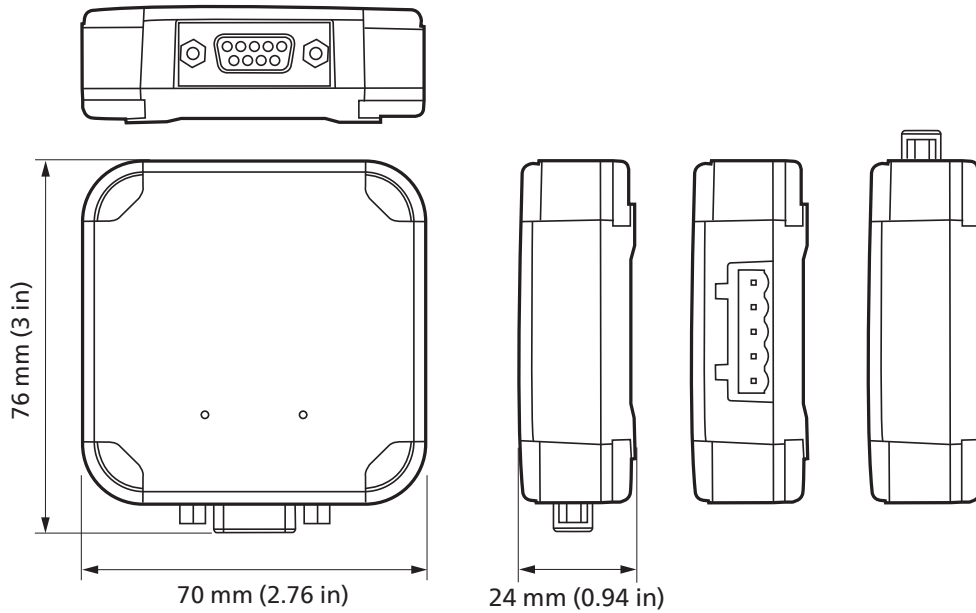

## Electrical

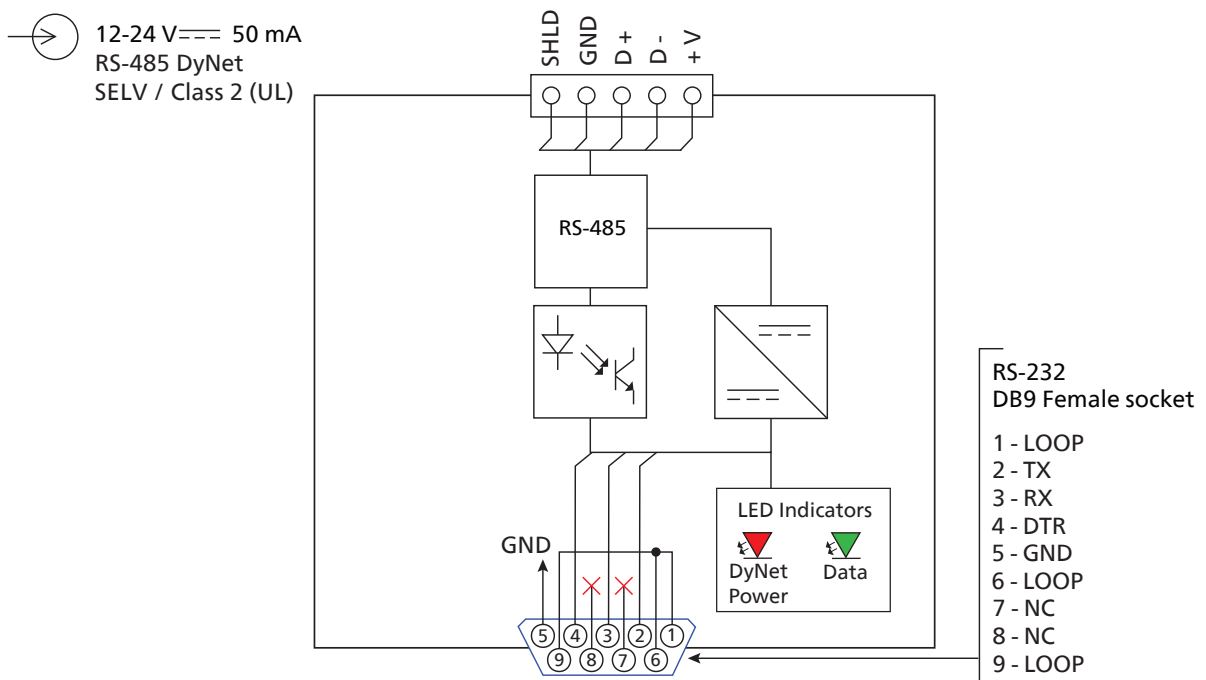

# Specifications

Due to continuous improvements and innovations, specifications may change without notice.



**PD-232N**  
PC Node

## Electrical

Supply Type	DyNet
Supply Voltage	12-24 VDC
Supply Current	50 mA
IEC Overvoltage Category	III

## Control

Serial Ports	1 x RS-485 1 x RS-232
Supported Protocols	DyNet
Indicators	1 x DyNet Power LED ● 1 x Data LED ●

## Physical

Dimensions (H x W x D)	76 x 70 x 24 mm (3.0 x 2.76 x 0.94 in)
Packed Weight	278 g (0.61 lb)
Construction	Polycarbonate
Serial Ports	1 x 5-way pluggable screw terminal 1 x DB9 Female
Screw Terminal Conductor Size	0.3-2.5 mm <sup>2</sup> (#22-12 AWG)

## Environment\*

Operating Temperature	0° to 50°C ambient (32° to 122°F)
Storage/Transport Temperature	-25° to 70°C ambient (-13° to 158°F)
Humidity	0 to 90% non-condensing
IEC Pollution Degree	II

## Compliance

Certification	CE, RCM, UKCA, FCC, ICES, RoHS
Ingress Protection	IP20

\* For indoor installation only



## Ordering Code

### Product

PD-232N

**Philips 12NC**

913703098409

## Accessories (Supplied)

1 x RS-232 Male-to-Female Cable

1 x 5-pin pluggable screw terminal

© 2025 Signify Holding.

All rights reserved. Specifications are subject to change without notice. No representation or warranty as to the accuracy or completeness of the information included herein is given and any liability for any action in reliance thereon is disclaimed. Philips and the Philips Shield Emblem are registered trademarks of Koninklijke Philips N.V. All other trademarks are owned by Signify Holding or their respective owners.



[www.dynalite.com](http://www.dynalite.com)

Revision 01 – 2025-04-01