

# ADVANCE

by  Signify

The affordable  
& reliable choice  
for easy indoor  
luminaire design-in

LED Drivers

Design-in Guide



# Contents

Introduction to this guide	3
Applications	3
Information or support	3
Safety precautions	4
Safety warnings and installation instructions	4
Introduction to CertaDrive indoor LED drivers	5
Introduction	5
CertaDrive value and creation	5
How to select an appropriate CertaDrive driver for your modules	6
CertaDrive Lumen & CCT Selectable Driver	6
Product naming	7
Electrical design-in	8
Surge protection	8
Leakage current	8
Electromagnetic compatibility (EMC)	8
Dynamic Resistance	8
Improvement in electromagnetic interference performance	9
Electrical isolation	10
Inrush current	10
Thermal design-in	11
Case temperature point (Tc point)	11
Dimming method	12
Mechanical mounting	14
Disclaimer	15

# Introduction to this guide



Examples of CertaDrive indoor LED drivers.

Thank you for choosing Advance CertaDrive indoor LED drivers. In this guide you will find the information needed to integrate these drivers into a LED luminaire or LED system.

This edition describes the CertaDrive indoor LED drivers optimized for indoor application. We advise you to consult our websites for the latest up-to-date information.

## Applications

The CertaDrive indoor LED drivers are designed to operate LED solutions for indoor lighting, like offices, public buildings and retail environments. If you use Advance LED drivers in combination with Advance LED modules, specific design-in guides are available from below mentioned technology websites.

## Information or support

Please consult your local Advance office or visit:  
<http://www.philips.com/oemna>

# Safety precautions



## Warnings:

- Avoid touching live parts!
- Do not use drivers with damaged wiring!

## Safety warnings and instructions to be taken into account during design-in and manufacturing include:

- Do not use damaged or defective contacts or housings.
- Do not service the driver when the mains voltage is connected; this includes connecting or disconnecting the LED load.
- Do not use damaged products.
- Cap off all unused wires to prevent accidental contact with the luminaire or driver housing.
- The luminaire manufacturer is responsible for its own luminaire design and has to comply with all relevant safety standards.
- The Advance CertaDrive LED driver is intended for built-in use and should not be exposed to the elements such as snow, water or ice. Exposure will lead to corrosion of the driver housing and should be avoided. It is the luminaire manufacturer's responsibility to prevent exposure. CertaDrive indoor LED drivers are specified for UL damp and dry locations.
- Driver must be installed in accordance with national and local electrical codes.
- The field-wiring leads or push-in terminals shall be fully enclosed.  
Les fils de câblage sur place ou les bornes enfichables doivent être entièrement fermés (Fr).
- For support with any of these aspects, please contact your local Advance sales representative.

# Introduction to CertaDrive indoor LED drivers



CertaDrive indoor LED drivers.

## Introduction

Advance CertaDrive indoor LED drivers are designed to meet basic general lighting need in commercial applications. Offered in specific voltage – current settings, these drivers are optimized with elementary specifications that are just appropriately suited for the application, making LED conversion even more attainable.

Within prescribed operating windows, CertaDrive drivers provide the OEM with the ability to match their LED board specifications with discrete voltage–current combinations that can be offered as fixed-current derivatives for both non-dimmable and dimmable applications.

## CertaDrive value and creation

### CertaDrive value proposition

Within the prescribed range supported by a released platform, CertaDrive enables fast time to market for customized solutions with specific (non-programmable) current and voltage settings for the LED module.

### CertaDrive creation

Prior to creating any CertaDrive solution a platform must first be created. This platform consists of a predefined range or window of current and voltage. From this platform, any CertaDrive with a specific current and voltage settings can be created for as long as those values for voltage and current fall within the window or platform boundaries. See examples in Figure 1.

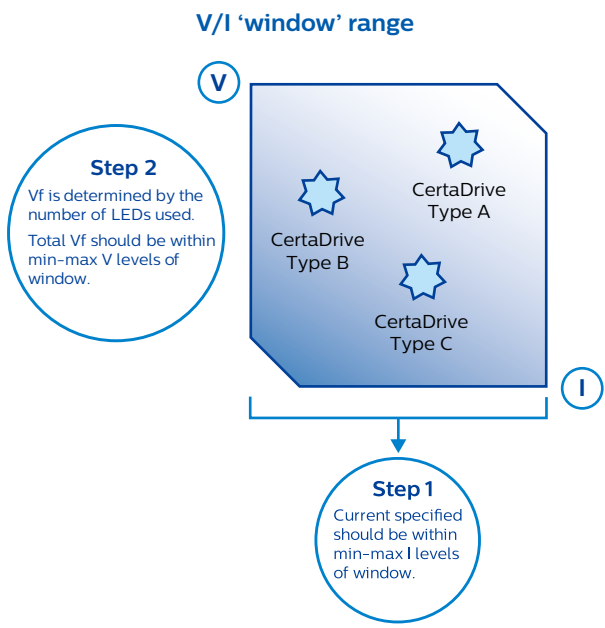

Figure 1. Flexibility to create specific and dedicated CertaDrive designs.

## How to select an appropriate CertaDrive driver for your modules

Depending on your requirements several drivers can be found as a solution for you. The following steps can help selecting the preferred driver.

1. Determine your required drive current ( $I_{drive}$ ) and voltage ( $V_{f\_range}$ \* of LED load).
2. Calculate required power via:  $P_{drive} (W) = V_f (V) \times I_{drive} (A)$ .
3. Does required current fit current range of driver?
  - $I_{driver\ minimum} < I_{drive} < I_{driver\ maximum}$
4. Does required voltage fit voltage range of driver?
  - $V_{driver\ minimum} < V_{f\_range} < V_{driver\ maximum}$
5. Does required power fit power range of driver?
  - $P_{driver\ minimum} < P_{drive} < P_{driver\ maximum}$
6. Choose your type of dimming (0-10V or non-dimmable).

\* Note: the selection of the  $V_{f\_range}$  take into account the tolerance factors for LED binning, temperature, aging, etc.

### CCT Selectable Switch

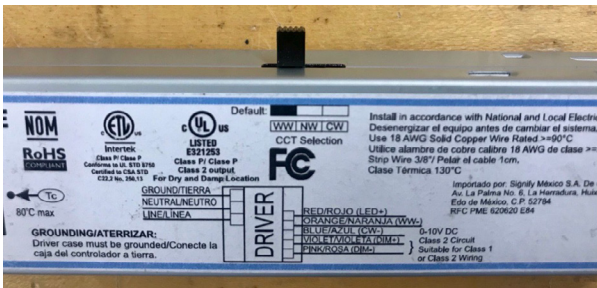

### Lumen Selectable Switch



### CertaDrive Lumen & CCT Selectable Driver

- 3 position switchable CCT setting (WW, NW, CW) available with a built-in mechanical switch.
- 3 position switchable Lumen setting (HIGH MED LOW) available with a built-in mechanical switch.
- 0-10V dimming control.
- Output current ratio between WW and CW for three CCT selection: WW (100%/0%), NW (50%/50%), CW (0%/100%).
- To get 50%/50% split ratio for NW, the  $V_f$  between WW and CW need to be closely matched.
- For operating range of output voltage, current and power, follow the guidelines on “How to select an appropriate CertaDrive driver for your modules”.
- Follow the wiring diagram for output connections:

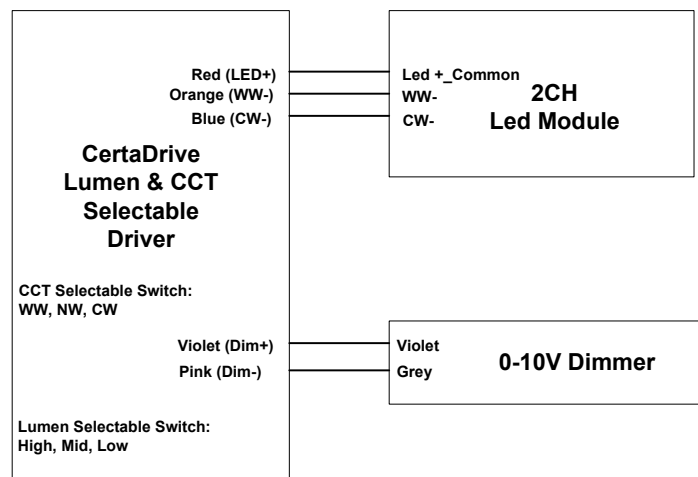

## Product naming

C	I	036	C078	V46	F	N	N	1	M
									Packaging: M=Midpack, I=Individual Pack, B=Bulk Pack
									Version Control: 1=Version 1, 2=Version 2, ...
									Enclosure Designation
									Features: N=Non-Programming
									Fixed or Dimming: C=0-10V    R=Leading Edge & Trailing Edge Dimming F=Fixed
									Max Voltage: Examples: 046=46V
									Max Current: Examples: 039=390mA, 078=780mA
									Max Power: Examples: 018=18W, 036=36W
									Input Voltage: I=120-277V    G=347V R=120V
General: C=CertaDrive LED									

# Electrical design-in

## Surge protection

The CertaDrive indoor LED drivers have built-in surge protection up to a certain limit. Additional protection against excessive high surges can be achieved by adding a surge protection device.

The actual limit can differ per driver and can be found in the driver's datasheet in the download section on <http://www.philips.com/oemna>.

## Leakage current

CertaDrive LED drivers are designed to meet leakage current requirements per UL 8750 standards. In a luminaire, leakage current may be higher since the LED load introduces additional parasitic capacitance. As such, precautions should be taken at the luminaire level and also if multiple drivers are used in the luminaire.

## Electromagnetic compatibility (EMC)

Advance CertaDrive LED drivers stating to comply with FCC Title 47 Part 15 Class A or Class B in datasheets are suitable for commercial and industrial lighting applications.

**Consumer Information for Class A Compliance:** This equipment has been tested and found to comply with the limits for a Class A digital device, pursuant to part 15 of the FCC Rules. These limits are designed to provide reasonable protection against harmful interference when the equipment is operated in a commercial environment. This equipment generates, uses, and can radiate radio frequency energy and, if not installed and used in accordance with the instruction manual, may cause harmful interference to radio communications. Operation of this equipment in a residential area is likely to cause harmful interference in which case the user will be required to correct the interference at his own expense.

### Consumer Information for Class B Compliance:

This equipment has been tested and found to comply with the limits for a Class B digital device, pursuant to part 15 of the FCC Rules. These limits are designed to provide reasonable protection against harmful interference in a residential installation.

This equipment generates, uses and can radiate radio frequency energy and, if not installed and used in accordance with the instructions, may cause harmful interference to radio communications. However, there is no guarantee that interference will not occur in a particular installation. If this equipment does cause harmful interference to radio or television reception, which can be determined by turning the equipment off and on, the user is encouraged to try to correct the interference by one or more of the following measures:

- Reorient or relocate the receiving antenna.
- Increase the separation between the equipment and receiver.
- Connect the equipment into an outlet on a circuit different from that to which the receiver is connected.
- Consult the dealer or an experienced radio/TV technician for help.

## Dynamic Resistance

All LEDs have a dynamic resistance component which is defined as the ratio of differential change in voltage to a differential change in current. This is because of the non-linear VI characteristics of LED forward voltage and forward current. The dynamic resistance changes by the type and number of LEDs (series/parallel combinations) and has an interaction with the output current ripple for the CertaDrive X and XCS LED drivers. This interaction causes the ripple to be higher with lower dynamic resistance, and when using LED boards with extremely low dynamic resistance, there maybe a risk to meet TLA requirements per NEMA 77. The Advance Fortimo LED Strip VOcs modules have been designed to perfectly pair with the CertaDrive XCS drivers to stay within the limits per NEMA 77. When using LED modules other than the Fortimo LED Strip product, it is recommended to confirm the TLA performance through an actual measurement. Also, in the design and selection of the LED modules, the suggestion is to try and have the dynamic resistance be higher than  $1.0\Omega$  at 200mA-3V per LED.

As an illustration: for a LED driver output current 1A and 36V, will consider 12LED in series per string (3V per LED) and 5 LED strings in parallel (200mA per LED), then the total dynamic resistance that the driver sees must be higher than  $2.4\Omega$  ( $12 \times 1/5$ ).

## Improvement in electromagnetic interference performance

The following practical precautions need to be taken into account in a lighting system to minimize EMI:

- Minimize the differential mode loop area of the LED wires going from the driver to the light source by keeping the wires close together (bundling). This will minimize the magnetic field and reduce the radiated EMI. Long linear light sources are also part of that loop.
- Minimize the common mode parasitic capacitance of the output wiring + light source to earth by keeping the length of the wires between driver and light source as short as possible. Keep the length of the incoming mains wire inside the luminaire as short as possible.
- Keep mains separated from the output wires (do not bundle).
- Do not route any wiring over and/or along the driver enclosure to avoid any coupling/crosstalk with internal components of the driver.
- Ground the lighting system chassis and other internal metal parts to protective earth, never let large metal parts be electrically insulated from functional or protective earth. Always connect the protective/functional earth/equipotential connector or wire from the driver and use equipotential bonding wires for all large metal parts like driver mounting plate, reflector, heatsink, etc. Keep the protective/functional earth/equipotential wires as short as possible to maximize their effectiveness and use, as much as possible, large metal areas (chassis, mounting plates, brackets) for earthing purposes instead. Establish a reliable electrical connection by using a toothed washer and screw(s) fastened with adequate torque.
- Sometimes radiated EMC compliance cannot be achieved, necessitating the use of a 100 ... 300  $\Omega$  axial ferrite bead(s) for either mains or lamp wiring (effective for interference between 30 MHz and 300 MHz), or coupling the wires through ferrite cores within the luminaire may improve the overall EMC performance. However, selection of the type and characteristics of the additional filter depends on what frequency components have to be damped and by how much.

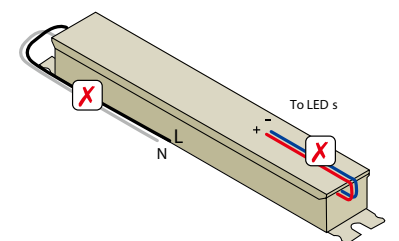
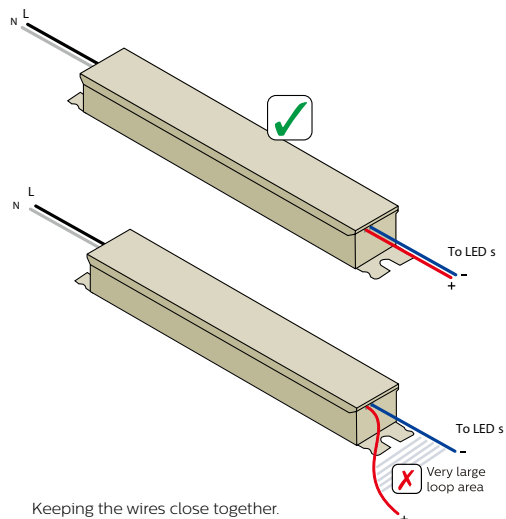

Adhering to these rules will help in EMC compliance.

For further questions, please contact your local Advance sales representative. Alternatively the Advance Lighting OEM design-in team could be consulted for a possible solution.

## Electrical isolation

Advance CertaDrive LED drivers meet the UL 8750 safety standard and the UL1310 Class 2 safety standard.

All of the wires in the Advance CertaDrive LED drivers meet the UL1452 safety standards.

## Inrush current

Inrush current refers to the brief high-input current that flows into the driver during the initial start-up to charge the capacitors on the input side. Typically, the amplitude is much greater than the operating or steady-state current, as illustrated in Figure 2.

CertaDrive drivers meet the inrush specification values per NEMA 410. The peak and duration values are given in the individual product datasheet.

The best way to reduce inrush is to turn on relays or switches at the zero crossing of the mains. Many controllers do this to reduce the large inrush currents.

What does inrush current do? High inrush currents can cause circuit breakers or fuses to open if not designed to handle this current. It can limit how many drivers can be connected to a circuit breaker (CB) or fuse.

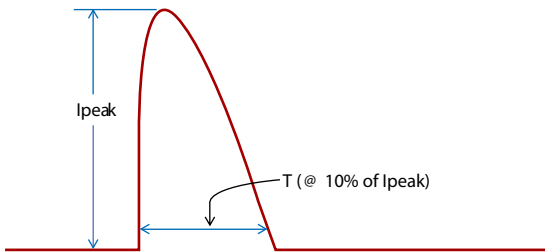

Figure 2. Graphical representation of inrush current.

### Note:

Please consult the fuse and circuit breaker manufacturer recommendations when selecting appropriate fuse and/or circuit breakers in conjunction with LED luminaires.

# Thermal design-in

The following section covers the critical thermal management points to facilitate design-in. Taking thermal considerations into account will help ensure optimum performance and lifetime of an LED system. The maximum case temperature ( $T_{c\_max}$ ) of the driver should not be exceeded. It is mandatory to keep driver  $T_{c\_max}$  within specification to meet driver lifetime and failure rate specifications. Please refer to individual product datasheets for specific values (specify CertaDrive number).

## Case temperature point

To achieve optimal lifetime and reliability, it is critical that the temperature of the components in the driver remain within its rating. In the driver design, all precautions are taken to ensure that the components within the driver are at the lowest possible temperatures.

Initial thermal analysis is performed via IR scans at room temperature to identify the hottest components of the driver. Subsequently, detailed measurements of the temperatures of the critical components are performed under various input/output conditions at the worst case operating temperatures.

These temperature measurements are related to a  $T_{c}$  point on the driver as shown in Figure 3.  $T_{c}$  point temperature is a good reference for the temperatures of the critical internal driver components.

The location of the  $T_{c}$  point is identified on the product label. The  $T_{c}$  point on the drivers is on the dot indicated by the arrow (see red circle in Figure 4). In some instances, the  $T_{c}$  point is marked with an arrow that traces to the middle of the housing as shown in Fig 5. In this instance the thermocouple is intended to be placed on the sidewall of the driver housing (below the cover edge line).

**Note:**  
 The specified  $T_{c\_max}$  of the driver must NEVER be exceeded.  
 Care must be taken to ensure thermal stability has been reached before recording  $T_{c}$  measurement.

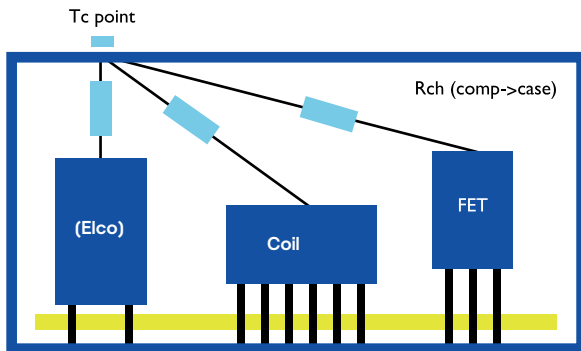

Figure 3. Internal resistance to the driver  $T_{c}$  point.

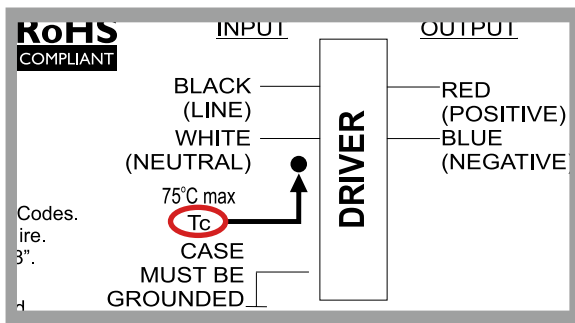

Figure 4. Product label indicating  $T_{c}$  point of an N can driver (detail).

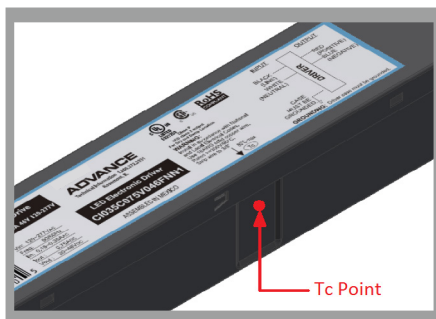

Figure 5. Example product label indicating  $T_{c}$  point.

# Dimming method



Figure 6. LED driver with 0–10V dimming interface

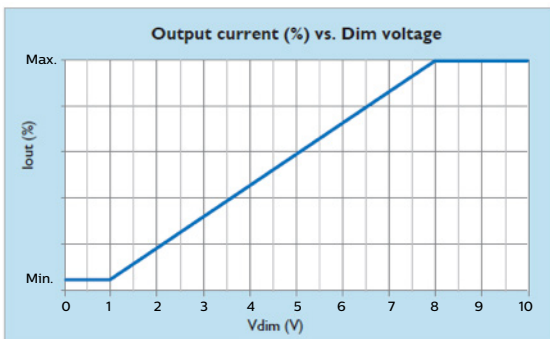

Figure 7. Output current in % vs dimming voltage (Linear dimming curve), example

## 0-10V dimming

0-10V is a commonly used dimming interface for LED drivers. The interface requires two wires (0-10V + and -) to connect an LED driver to a 0-10V dimmer (Figure 6). The LED driver provides approximately typical 150 $\mu$ A sourcing current to the dimmer, this sourcing current has some variations. Dimming curve is shown in Figure 7.

Note that the output current at 100% level is determined by the driver. The absolute minimum and absolute maximum output current that can be supplied by the driver is specified in the datasheet, and this is limited by the driver hardware.

For Class 2 drivers, the 0-10V dimming leads are isolated from the mains and isolated from the Class 2 output. Thus, the dimming leads are suitable for Class 1 and Class 2 wiring.

When long dimming wires are required in some applications, maximum length of the dimming wires can be estimated based on voltage drop on the dimming wires. The recommended max voltage drop on the two wires is 100mV.

## 0-10V Leakage Current

Even though dimming leads of LED drivers meet Class 2 requirements, when multiple drivers are connected together to one dimmer, the leakage current to the dimmer from each driver will be added together. In these situations, precaution is recommended for the system to meet applicable safety requirements.

The recommended maximum number N of control circuit in parallel could be calculated by:

$$N = 80\% \times 3.5 \text{ mA} / \text{xxx mA}$$

where xxx mA stands for one driver's control leads leakage current level. This value could be found in driver's datasheet

For example, if one LED driver's leakage current of 0-10V dimming leads is 0.015 mA, the recommended maximum number N of this type of driver's 0-10V dimming leads in parallel is:

$$N = 80\% \times 3.5 \text{ mA} / 0.015\text{mA} = 180$$

The maximum number of drivers that may be connected in the same control circuit maybe be from 64 to 280. For specific recommendations please contact your Signify Key Account Manager or Signify customer service at 1-800-372-3331.

		AWG Wire Size					
		12	14	16	18	20	22
Output Current (A)	0.35	855	540	340	215	136	85.5
	0.53	565	356	225	142	89.5	56.5
	0.7	428	270	170	107	67.8	42.8
	1.05	285	180	113	71.6	45.2	28.5
	1.5	200	126	79.4	50.1	31.6	20
	2	150	94.4	59.6	37.6	23.7	15
	3	100	62.9	39.7	25.1	15.8	10
	4	75	47.2	29.8	18.8	11.9	7.5
	5	59.9	37.8	23.8	15	9.5	6

Table 1. Max allowed distance between driver and LED module feet (based on 1V drop).

		AWG Wire Size				
		14	16	18	20	22
Number of Drivers	10	15738	9925	6263	3950	2500
	20	7863	4963	3138	1975	1250
	30	5250	3313	2088	1313	838
	40	3938	2488	1563	988	625
	50	3150	1988	1250	788	500
	60	2625	1650	1050	663	413
	70	2250	1413	900	563	363
	80	1963	1238	788	500	313
	90	1750	1100	700	438	275
	100	1575	988	625	400	250

Table 2. Max allowed length 0-10V control when in feet (based on 100mV drop and 150µA drive current).

## Important

- Keep wiring between the driver and the LED module as short as possible. However, “remote wiring” is acceptable, and Table A gives an indication of remote mounting distance vs. driver current and AWG wire size. The table is based on the assumption that a 1V drop is acceptable (For example: the driver output voltage rating must be at least 1V higher than the maximum LED voltage). Please consult your local Advance sales representative for further design-in services about calculating the voltage drop and wire losses.
- Keep in mind that remote mounting also impacts efficiency of the system (as an example, a 1V drop on a 4A driver results in 4W losses in the wiring, so if lower losses are desired, a correspondingly large wire size should be chosen). Also, the remote mounting impacts electromagnetic interference (EMI) behavior, and additional measures may be necessary to reduce EMI if remote mounting is used (for example, adding a ferrite clamp around output wires would reduce radiated EMI). In general, lead length should be kept as short as possible to avoid EMI issues.
- Depending on wire gauge, the length of dimming wires begins to add a voltage drop to cause a shift in dim level from the intended target. This is a minimal shift in voltage and is not sufficient to become noticeable. Table B gives an indication for dim lead wiring lengths assuming a maximum offset of 100mV for different numbers of drivers connected to a single controller.
- For driver's connectors, please check the driver datasheet to determine appropriate wire gage for connectors.

# Mechanical mounting

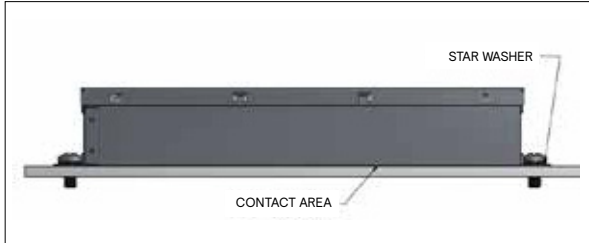

Figure 5. Chassis mounting.

Mounting of the LED driver must satisfy three critical issues:

**1) Solid fastening of the driver in order to avoid movement of the driver relative to luminaire**

The size of mounting screws/bolts needs to be the maximum allowed by the size of driver mounting holes/slots. The tightening torque has to be per screw/bolt manufacturer recommendations.

**2) Electrical grounding of the driver**

The driver enclosure is painted. It is recommended to use star washers under the head of the mounting screws – the teeth of the star washer breaks through the paint to ensure electrical connection to the grounded fixture.

**3) Maximum interface area between driver enclosure surface and luminaire mounting surface (cooler) for best possible driver  $T_{case}$  temperature (lowest)**

Figure 5 illustrates recommended mounting of the driver. Thermally conductive gap pads (or other thermally conductive grease, paste, etc.) may be used between driver and luminaire surface to eliminate air gaps and further improve driver thermal performance (lower  $T_{case}$  temperature).

# Disclaimer

The information in this guide is accurate at the time of writing. This guide is provided “as is” without expressed or implied warranty of any kind. Neither Advance nor its agents assume any liability for inaccuracies in this guide or losses incurred by use or misuse of the information in this guide.

Advance will not be liable for any indirect, special, incidental or consequential damages (including damages for loss of business, loss of profits or the like), whether based on breach of contract, tort (including negligence), product liability or otherwise, even if Advance or its representatives have been advised of the possibility of such damages.

