



MASTER VALUE LED spot LV

MASTER LED 4.9-50W 3000K MR16 36D

LEDspot, MR16, 50 W, GU5.3, 3000 K, 425 lm, 25000 hour(s), Metal

Delivering a warm, halogen-like accent beam, MASTER LEDspot LV is an ideal retrofit solution for spot and general lighting applications in the hospitality industry. It is particularly suited to public areas such as receptions, lobbies, corridors, stairwells and washrooms, where the light is on all the time. The robustly designed MASTER LEDspot offers a choice of beam angles for a clearly defined beam spread. There is no UV or IR in the beam, making it suitable for illuminating heat-sensitive objects (food, organic materials, paintings, etc.). The patented intelligent driver enables broad compatibility with existing electromagnetic and electronic halogen transformers. The dimmable versions drive further efficiencies, while helping to create the desired atmosphere.

Warnings and Safety

- Operating temperature range is between -20° C and 45° C ambient
- Only to apply in dry or damp locations and most of open fixtures with lamp-holders that offer sufficient space (10 mm free air space)
- Not intended for use with emergency light fixtures or exit lights

Product data

General Information		Lighting Technology	
Cap-Base	GU5.3	LEDspot	
Nominal lifetime	25,000 hour(s)	Light Technical	
Switching Cycle	50,000	Color Code	930 [CCT of 3000K]
		Beam Angle (Nom)	36 degree(s)

MASTER VALUE LED spot LV

Luminous Flux	425 lm
Luminous Intensity (Nom)	950 cd
Color Designation	White (WH)
Correlated Color Temperature (Nom)	3000 K
Luminous Efficacy (rated) (Nom)	86 lm/W
Color Consistency	<6
Color rendering index (CRI)	90
LLMF At End Of Nominal Lifetime (Nom)	70 %
Photobiological safety according to EN 62471	RG1

Operating and Electrical

Input Frequency	- Hz
Power Consumption	4.9 W
Lamp Current (Nom)	484 mA
Wattage Equivalent	50 W
Starting Time (Nom)	0.5 s
Warm-up time to 60% light	0.5 s
Power Factor (Fraction)	0.7
Voltage (Nom)	ac electronic 12 V

Temperature

T-Case Maximum (Nom)	72 °C
----------------------	-------

Controls and Dimming

Dimmable	No
----------	----

Mechanical and Housing

Bulb Finish	Clear
Bulb Material	Metal
Bulb Shape	MR16
Net Weight (Piece)	0.037 kg

Approval and Application

Suitable For Accent Lighting	Yes
EU RoHS compliant	Yes
Ambient temperature range	-20 to +45 °C

Application Conditions

Wireless Technology	Not applicable
---------------------	----------------

Product Data

Order product name	MASTER LED 4.9-50W 3000K MR16 36D	
Full product name	MASTER LED 4.9-50W 3000K MR16 36D	
Full product code	872016917462700	
Order code	17462700	
Material Nr. (12NC)	929003611008	
Numerator - Quantity Per Pack	1	
EAN/UPC - Product/Case	8720169174627	
Numerator - Packs per outer box	10	
EAN/UPC - Case	8720169174634	

Dimensional drawing

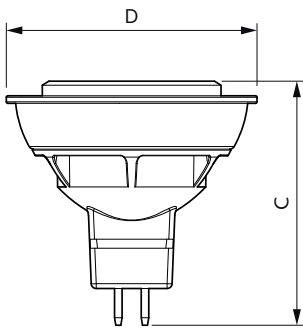

Product	D	C
MASTER LED 4.9-50W 3000K MR16 36D	50.5 mm	50 mm

MASTER VALUE LED spot LV

Photometric data

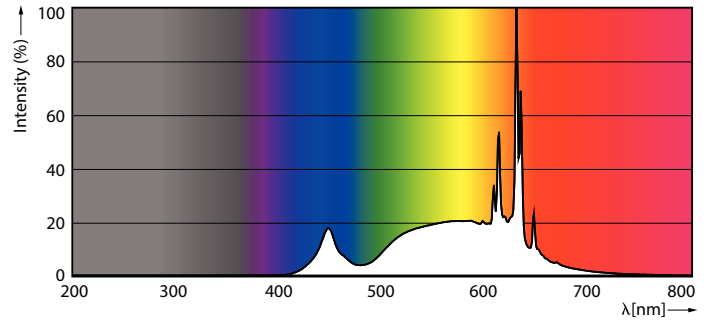
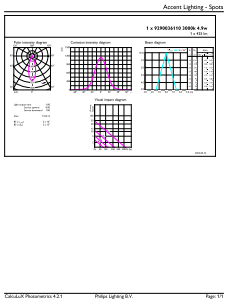

Accent Lighting Spots - MASTER LED 4.9-50W 3000K MR16 36D

Spectral Power Distribution Colour - MASTER LED 4.9-50W 3000K MR16 36D

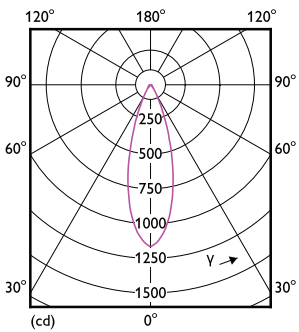

Light Distribution Diagram - MASTER LED 4.9-50W 3000K MR16 36D

Lifetime

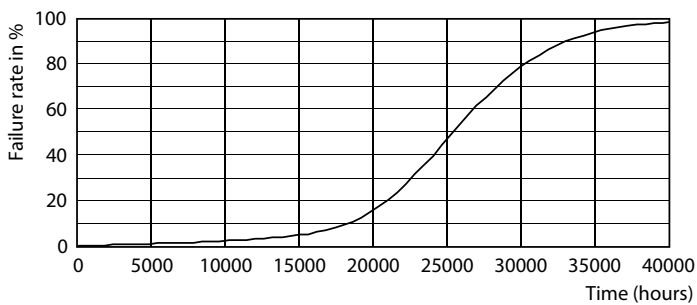

Life Expectancy Diagram

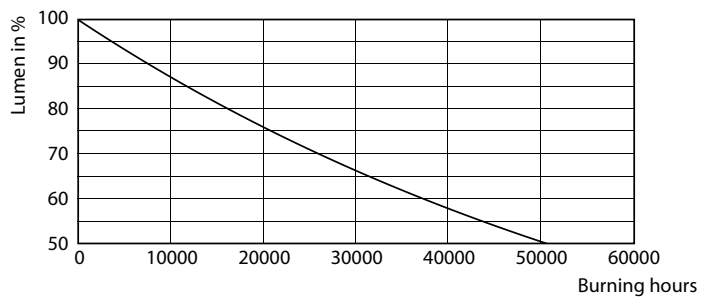

Lumen Maintenance Diagram - MASTER LED 4.9-50W 3000K MR16 36D

MASTER VALUE LED spot LV

