



MASTER SON-T PIA Plus

MASTER SON-T PIA PLUS 150W E E40 1SL/12

High Pressure Sodium lamp with clear tubular outer bulb, high output and long reliable lifetime

Warnings and Safety

- Control gear must include end-of-life protection (IEC60662, IEC 62035)
- A lamp breaking is extremely unlikely to have any impact on your health. If a lamp breaks, ventilate the room for 30 minutes and remove the parts, preferably with gloves. Put them in a sealed plastic bag and take it to your local waste facilities for recycling. Do not use a vacuum cleaner.

Product data

General Information	
Cap-Base	E40
Operating Position	UNIVERSAL [Any or Universal (U)]
Life to 50% Failures (Nom)	32,000 hour(s)

Light Technical	
Color Code	220 [CCT of 2000K]
Luminous Flux	17,800 lm
Chromaticity Coordinate X (Nom)	0.535
Chromaticity Coordinate Y (Nom)	0.420
Correlated Color Temperature (Nom)	2000 K
Luminous Efficacy (rated) (Nom)	115 lm/W

Operating and Electrical	
Power Consumption	154.0 W
Voltage (Nom)	100 V

Controls and Dimming	
Dimmable	No

Mechanical and Housing	
Bulb Finish	Clear
Bulb Shape	T46
Net Weight (Piece)	0.106 kg

Approval and Application	
Mercury (Hg) Content (Nom)	13.9 mg
Energy Consumption kWh/1000 h	169 kWh

Product Data	
Order product name	MASTER SON-T PIA PLUS 150W E E40 1SL/12
Full product name	MASTER SON-T PIA PLUS 150W E E40 1SL/12
Full product code	692234199944400
Order code	928483400093

MASTER SON-T PIA Plus

Material Nr. (12NC)	928483400093
Numerator - Quantity Per Pack	1
EAN/UPC - Product/Case	6922341999444
Numerator - Packs per outer box	12

EAN/UPC - Case	6922341993053
----------------	---------------

Dimensional drawing

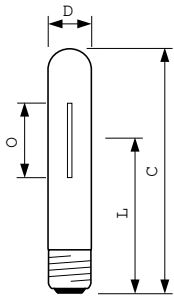

Product	D (max)	O	L	C (max)
MASTER SON-T PIA PLUS 150W E E40 1SL/12	47 mm	61 mm	132 mm	209 mm

Photometric data

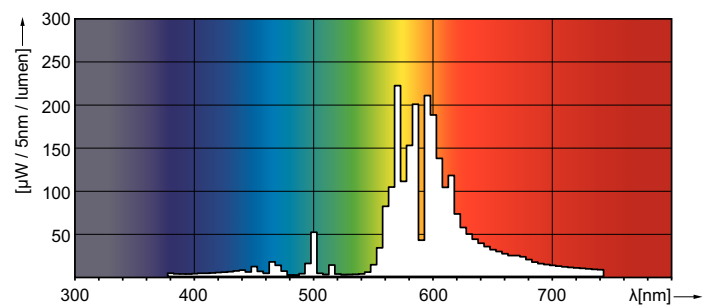
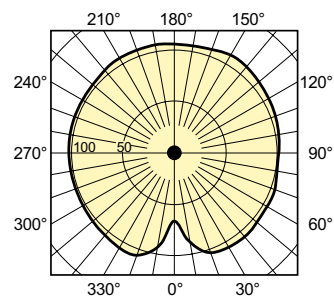
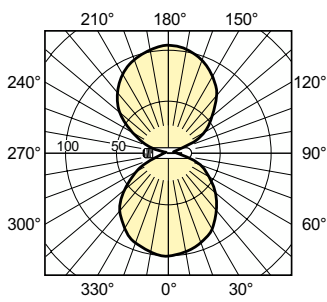

Light Distribution Diagram - MASTER SON-T PIA PLUS 150W E E40 1SL/12

Spectral Power Distribution Colour - MASTER SON-T PIA PLUS 150W E E40 1SL/12

Lifetime

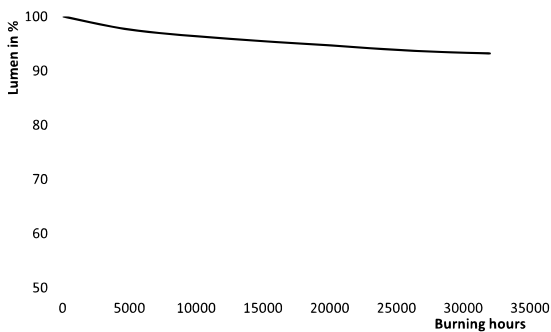

Lumen Maintenance Diagram - MASTER SON-T PIA PLUS 150W E E40 1SL/12

MASTER SON-T PIA Plus

