



MASTER MHN-FC

MASTER MHN-FC 2200W/640 400V XW

Compact quartz metal halide lamps with double pinch

Warnings and Safety

- Use only in totally enclosed luminaire, even during testing (IEC61167, IEC 62035, IEC60598)
- The luminaire must be able to contain hot lamp parts if the lamp ruptures
- A lamp breaking is extremely unlikely to have any impact on your health. If a lamp breaks, ventilate the room for 30 minutes and remove the parts, preferably with gloves. Put them in a sealed plastic bag and take it to your local waste facilities for recycling. Do not use a vacuum cleaner.

Product data

General Information	
Cap-Base	Double Ended
Operating Position	P5 [Parallel +/-5D or Horizontal(HOR)]
Life to 50% Failures (Nom)	9,300 hour(s)

Light Technical	
Color Code	640 [CCT of 4000K]
Color Designation	White (WH)
Chromaticity Coordinate X (Nom)	382
Chromaticity Coordinate Y (Nom)	400
Correlated Color Temperature (Nom)	4100 K
Luminous Efficacy (rated) (Nom)	105 lm/W
Color rendering index (CRI)	60
Arc Length O (Nom)	108 mm

Operating and Electrical	
Power Consumption	2,240.0 W
Voltage (Nom)	230 V

Controls and Dimming	
Dimmable	No

Mechanical and Housing	
Bulb Finish	Clear
Net Weight (Piece)	0.166 kg

Approval and Application	
Mercury (Hg) Content (Nom)	103 mg
Energy Consumption kWh/1000 h	2,464 kWh

Product Data	
Order product name	MASTER MHN-FC 2200W/640 400V XW
Full product name	MASTER MHN-FC 2200W/640 400V XW
Full product code	871869641777500
Order code	928079805130
Material Nr. (12NC)	928079805130
Numerator - Quantity Per Pack	1
EAN/UPC - Product/Case	8718696417775

MASTER MHN-FC

Numerator - Packs per outer box	1
EAN/UPC - Case	8718696417782

Dimensional drawing

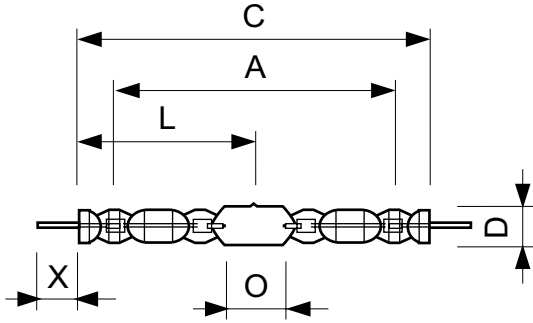

Product	D (max)	D	O	X	L	A	C (max)
MASTER MHN-FC 2200W/640 400V XW	33 mm	25.5 mm	108 mm	58 mm	177 mm	290 mm	476 mm

Photometric data

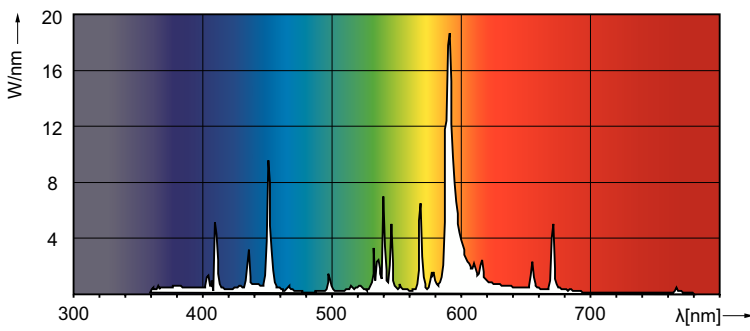

Spectral Power Distribution Colour - MASTER MHN-FC 2200W/640 400V XW

Lifetime

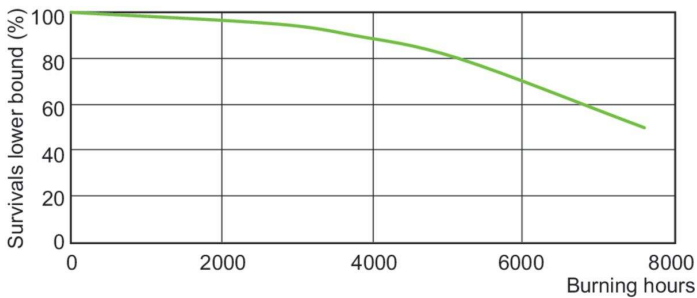

LDLE_MHN-FC_2200W_640-Life expectancy diagram

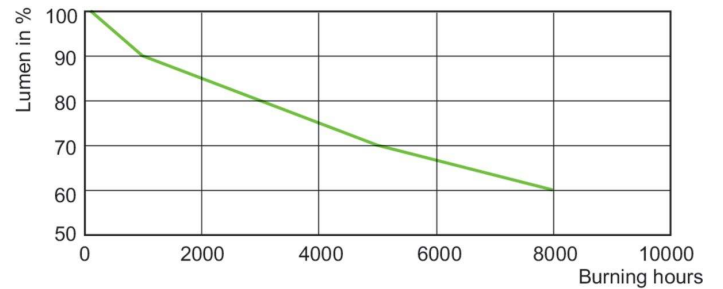

Lumen Maintenance Diagram - MASTER MHN-FC 2200W/640 400V XW

