



HF-Regulator Intelligent Touch DALI for TL5/TL-D/PL-L lamps

HF-Ri TD 2 14/21/24/39 E+

This intelligent high-frequency electronic dimming ballast utilizes the DALI or Touch and Dim push-button protocol for fluorescent lamps. It meets A1BAT requirements, thereby pre-empting upcoming legislation. With a special command you can retrieve the system's mains power consumption, and with another you can find out which lamp wattage is connected. Combined with controls, additional energy savings can be achieved. The ballast is primarily designed for Indoor application. For outdoor application, the luminaire should be minimum Classland need to be sufficiently protected against water & dust. The installation should also be guard against any lightening surge or any other necessary electrical protection as deemed in such typical installation & application.

Product data

Operating and Electrical	
Input Voltage	195-240 V
Line Frequency	50 to 60 Hz
Input Frequency	50 to 60 Hz
Earth Leakage Current (Max)	0.5 mA
Inrush Current Width	0.26 ms
Inrush Current Peak (Max)	27 A
Number of Products on MCB (16A Type B) (Nom)	16

Wiring	
Connector Type Input Terminals	WAGO 251 universal connector [Suitable for both automatic wiring (ALF and ADS) and manual wiring]
Connector Type Output Terminals	WAGO 251 universal connector [Suitable for both automatic wiring (ALF and ADS) and manual wiring]
Temperature	
T-Case Lifetime (Max)	75 °C

HF-Regulator Intelligent Touch DALI for TL5/TL-D/PL-L lamps

T-Case Maximum (Max)	75 °C
Controls and Dimming	
Control Interface	TD
Mechanical and Housing	
Housing	L 360x30x21
Ingress protection code	IP20 [Finger-protected]
Net Weight (Piece)	0.316 kg
Approval and Application	
Energy Efficiency Index	A1 BAT
Safety Standard	IEC 61347-2-3
Environmental Standard	ISO 14001
Approval Marks	CE marking ENEC certificate VDE-EMV certificate

CE mark	Yes
Ambient temperature range	-25 °C to 50 °C
Product Data	
Order product name	HF-Ri TD 2 14/21/24/39 E+
Full product name	HF-Ri TD 2 14/21/24/39 E+
Full product code	871829169691900
Order code	913700698466
Material Nr. (12NC)	913700698466
Numerator - Quantity Per Pack	1
EAN/UPC - Product/Case	8718291696919
Numerator - Packs per outer box	12
EAN/UPC - Case	8718291696926

Dimensional drawing

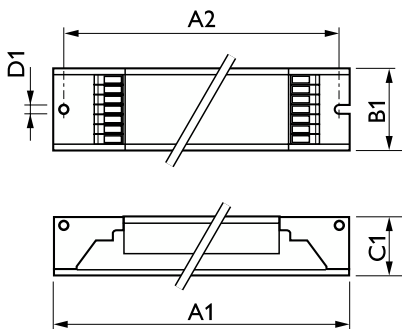

Product	D1	C1	A1	A2	B1
HF-Ri TD 2 14/21/24/39 E+	4.1 mm	21.0 mm	360.0 mm	350.0 mm	30.0 mm

