

PrimaVision Compact for CDM

HID-PV C 70 /S CDM 220-240V 50/60Hz

High-quality, compact and lightweight HID electronic gear for optimal and reliable performance of 20, 35, 50 and 70 W CDM lamps

Product data

Operating and Electrical		Approval and Application	
Input Voltage	220 to 240 V	Safety Standard	EN 61347-2-12
Line Frequency	50 to 60 Hz	Environmental Standard	ISO 14001
Input Frequency	50 to 60 Hz	Approval Marks	CE marking ENEC certificate
Inrush Current Width	0.33 ms	CE mark	Yes
Inrush Current Peak (Max)	33 A	Ambient temperature range	-20 °C to 50 °C
Number of Products on MCB (16A Type B) (Nom)	20	Product Data	
Wiring		Order product name	HID-PV C 70 /S CDM 220-240V 50/60Hz NG
Cable Length From Device to Lamp	1.5 m	Full product name	HID-PV C 70 /S CDM 220-240V 50/60Hz
Connector Type	Insert	Full product code	872790085974400
Temperature		Order code	85974400
T-Case Lifetime (Nom)	80 °C	Material Nr. (12NC)	913700652966
T-Case Maximum (Max)	80 °C	Numerator - Quantity Per Pack	1
Mechanical and Housing		EAN/UPC - Product/Case	8711500881694
Housing	/S	Numerator - Packs per outer box	12
Net Weight (Piece)	0.216 kg	EAN/UPC - Case	8727900859744

PrimaVision Compact for CDM

Dimensional drawing

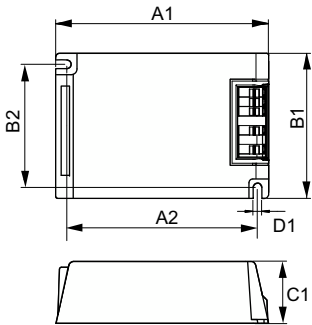

Product	D1	C1	A1	A2	B1	B2
HID-PV C 70 /S CDM 220-240V 50/60Hz NG	4.9 mm	32.2 mm	109.6 mm	98.5 mm	74.4 mm	63.7 mm

