



Essential Smartbright Projector (Wide Voltage) Gen 2

ST033T G2 LED6/940 7W WV WB WH

Essential Smartbright Projector (Wide Voltage) Gen 2, 7 W, 595 lm, 4000 K, 36°

Essential SmartBright Projector ST033T is a value for money product designed for Mass market trade. It is designed to replace halogen and CDM-standard-based projectors for retail and hospitality applications. This track based luminaire supports retailers to let their products stand out, or highlight certain objects. The clean and contemporary design with integrated driver makes the Essential SmartBright Projector relevant to many applications. The choice of 2 colors in White and Black helps the Retailer to choose products best suited to blend into the Store Environment. Compared to it's predecessor, it is not only cost effective, but also a more sleek and lighter product design.

Product data

General Information	
Number of gear units	1 unit
Gear	EB [Electronic]
Driver included	Yes
Light source engine type	LED
Value ladder	Value
Warranty period	2 years

Light Technical	
Luminous Flux	595 lm
Correlated Color Temperature (Nom)	4000 K
Luminous Efficacy (rated) (Nom)	85 lm/W
Color rendering index (CRI)	>90
Number of light sources	1
Beam angle of light source	36 degree(s)
Light source color	940 neutral white
Optic type	Beam angle 36° Wide beam

Essential Smartbright Projector (Wide Voltage) Gen 2

Luminaire light beam spread	36°
Unified glare rating CEN	Not applicable
Effective projected area	0.75 m²

Operating and Electrical

Input Voltage	110 to 240 V
Line Frequency	50 or 60 Hz
Inrush current	7.15 A
Inrush time	0.017 ms
Power Consumption	7 W
Power Factor (Fraction)	0.9
Connection	Track
Cable	-
Number of products on MCB of 16 A type B	100
Suitable for random switching	No
Protection class IEC	Safety class II

Controls and Dimming

Dimmable	-
Control interface	-
Maximum dim level	Not applicable

Mechanical and Housing

Housing Material	Aluminium
Reflector material	-
Optic material	Polycarbonate
Optical cover material	Polycarbonate
Housing Color	White RAL 9003
Mounting device	-
Optical cover finish	Clear
Overall length	128 mm
Overall width	49 mm
Overall height	166 mm
Overall diameter	49 mm
Dimensions (Height x Width x Depth)	166 x 49 x 128 mm

Ingress protection code	IP20 [Finger-protected]
Mech. impact protection code	IK03 [0.3 J]
Optical cover type	Polycarbonate
Net Weight (Piece)	0.220 kg

Approval and Application

Glow-wire test	Temperature 650 °C, duration 30 s
Flammability mark	For mounting on normally flammable surfaces
CE mark	No
ENEC mark	-
Photobiological risk	Photobiological risk group 1 @200mm to EN62778
Photobiological risk specification	0.2 m
EU RoHS compliant	Yes
Performance ambient temperature Tq	25 °C
Ambient temperature range	-20 °C to 45 °C

Initial Performance (IEC Compliant)

Luminous flux tolerance	-0%, +20%
Initial chromaticity	(0.38, 0.38) SDCM<5
Power consumption tolerance	+/-10%

Product Data

Order product name	ST033T G2 LED6/940 7W WV WB WH
Full product name	ST033T G2 LED6/940 7W WV WB WH
Full product code	872016976713399
Order code	911401844587
Material Nr. (12NC)	911401844587
Numerator - Quantity Per Pack	1
EAN/UPC - Product/Case	8720169767133
Numerator - Packs per outer box	30
EAN/UPC - Case	8720169767294

Dimensional drawing

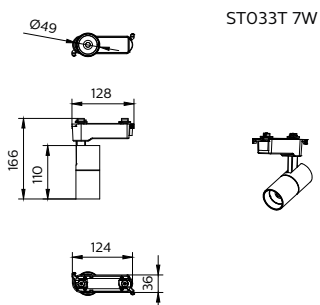

Essential Smartbright Projector (Wide Voltage) Gen 2

