



LumiStreet gen2

BGP292 LED49-4S/740 I DX10 7024 D9 48/60

LumiStreet gen2, Road & street light, 29 W, 4263 lm, 4000 K, CRI70, DALI, Distribution extra-wide 10, Safety class I, IP66

Increasing numbers of municipalities are having to upgrade large-scale conventional street lighting installations with energy-efficient LED technology. But they are having to do this with smaller and smaller budgets. That's why the new generation of LumiStreet has been upgraded and designed to provide a solution to this challenge, it is the ideal solution for performing point-to-point replacement of conventional lighting. LumiStreet gen2 achieves this by offering high-efficiency, low Total Cost of Ownership and ease of installation and maintenance. The ease of installation and maintenance is enabled by the Philips Service tag. Moreover, the Philips SR (System Ready) socket makes it future-ready and you can pair this luminaire with lighting control and software applications such as Interact City.

Product data

General Information		Warranty period	5 years
Lamp family code	LED49 [LED module 4900 lm]	Sustainability rating	Signify Circle
Light source replaceable	Yes	Light Technical	
Number of gear units	Unit	Upwards light output ratio	0
Driver included	Yes	Luminous Flux	4,263 lm
Light source engine type	LED	Correlated Colour Temperature (Nom)	4000 K
Service Tag	Yes	Luminous efficacy (rated) (nom.)	147 lm/W
Lighting Technology	LED	Colour rendering index (CRI)	70
Value ladder	Specification	Light source colour	740 neutral white
Serviceability class	Class A, the luminaire is equipped with serviceable parts (when applicable): LED board, driver, control units, surge-protection device, optics, front cover and mechanical parts	Luminaire light beam spread	150° - 43° x 67°
		Optic type outdoor	Distribution extra-wide 10

LumiStreet gen2

Effective projected area	0.0251 m ²
--------------------------	-----------------------

Operating and Electrical

Input Voltage	220 to 240 V
Line Frequency	50 to 60 Hz
Inrush current	21 A
Inrush time	0.225 ms
Power Consumption	29 W
Power Factor (Fraction)	0.97
Connection	2 push-in connectors 5-pole
Cable	-
Number of products on MCB (16 A type B)	30
Protection class IEC	Safety class I
Surge Protection (Common/Differential)	Surge protection level until 6 kV differential mode and 8 kV common mode

Controls and Dimming

Dimmable	Yes
Driver/power unit/transformer	Power supply unit with DALI interface
Control interface	DALI
Constant light output	No
DALI standard	DALI-2™
Maximum dim level	0% (digital)

Mechanical and Housing

Housing material	Aluminium die cast
Reflector material	Polycarbonate
Optic material	Polymethyl methacrylate
Optical cover/lens material	Glass
Fixation material	Aluminium
Housing Colour	Grey
Mounting device	Side-entry for diameter 48 to 60 mm
Optical cover/lens shape	Flat
Optical cover/lens finish	Clear
Overall length	620 mm
Overall width	234 mm
Overall height	95 mm
Dimensions (height x width x depth)	95 x 234 x 620 mm
Ingress protection code	IP66 [Dust penetration-protected, jet-proof]
Mech. impact protection code	IK09 [10 J]
Standard tilt angle post-top	0°
Standard tilt angle side entry	0°
Optical cover type	Flat glass
Net Weight (Piece)	5.100 kg

Approval and Application

Flammability mark	For mounting on normally flammable surfaces
CE mark	Yes
ENEC mark	ENEC plus mark
EU RoHS compliant	Yes
Performance ambient temperature Tq	25 °C
Remarks	* At extreme ambient temperatures the luminaire might automatically dim down to protect components
Ambient temperature range	-40 to +50 °C

Initial Performance (IEC Compliant)

Luminous flux tolerance	+/-7%
Initial chromaticity	(0.381, 0.379) SDCM <5
Power consumption tolerance	+/-10%
Init. Colour Rendering Index Tolerance	+/-2
Standard Deviation of Colour Matching (McAdam ellipse)	SDCM≤5

Over Time Performance (IEC Compliant)

Driver failure rate at 5,000 hours	0.5 %
Control gear failure rate at median useful life 50,000 h	5 %
Control gear failure rate at median useful life 100,000 h	10 %
Lumen maintenance (EN-IEC 62722-2-1) at median useful life* 50000 h	L99
Lumen maintenance (EN-IEC 62722-2-1) at median useful life* 100000 h	L97

Product Data

Order product name	BGP292 LED49-4S/740 I DX10 7024 D9 48/60
Full product name	BGP292 LED49-4S/740 I DX10 7024 D9 48/60
Full EOC	871951407964900
Order code	910925866698
Material no. (12 NC)	910925866698
Numerator – quantity per pack	1
EAN/UPC – Product/Case	8719514079649
Numerator – packs per outer box	1
EAN/UPC - Case	8719514079649
Product family code	BGP292 [LumiStreet gen2 Mini]

LumiStreet gen2

Dimensional drawing

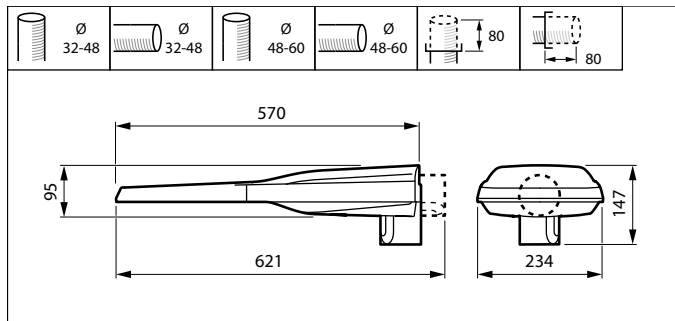

Photometric data

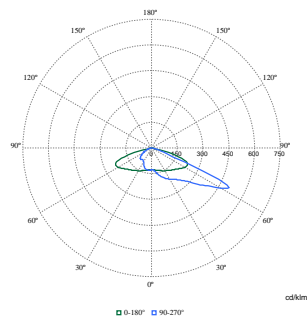

Polar Normal (separate) - BGP282I - 910925866698

