

CHLORIDE

by 



Exit/Emergency

PathMaster

LED die-cast mini step light

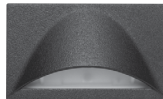

Project: _____
 Location: _____
 Cat.No: _____
 Type: _____
 Lamps: _____ Qty: _____
 Notes: _____

Ordering guide

Example: P1SBK

Series	Input Voltage	Lens	Finish ¹	Factory Options
		S		
P PathMaster PH PathMaster Horizontal Mount	1 12V AC,DC 2 120 VAC	S Satin	WH White BK Black A Aluminum BR Dark Bronze	DIM Line Voltage Dimmable ² AMB Amber LEDs BLU Blue LEDs

Footnotes

- ¹ Custom colors are available. RAL# must be provided.
² Line voltage dimmable driver available only with 120 VAC (P2, PH2) models.

codes and standards

- ETL Listed (US/Canada)
- UL wet location listed standard
- NFPA 101, NEC, IBC, BOCA, and OSHA illumination standard
- Meets ADA specifications for wall mounted lighting fixtures

construction

- The PathMaster Series is constructed from premium die cast aluminum components and is painted in a durable powder coat finish.
- Numerous standard finishes available with optional finishes available for custom projects.
- PathMaster is assembled as a one-piece device that includes the LED light engine, integral power supply, three level intensity control or line voltage dimmable driver (120 VAC models only).
- All LED and electrical components are protected by both a polycarbonate lens and high impact power supply case that will be located within the junction box.
- A neoprene gasket is provided standard for exterior applications.

installation

- The PathMaster Series is designed for direct mounting to a single gang junction box.
- The PathMaster is fastened to the single-gang junction box via two oval head 6x32x1/2" machine screws (supplied with product); junction boxes are not supplied with the product.
- When installing PathMaster in an outdoor damp or wet location, a single gang "FS" style junction box will be required by most local electrical codes.
- Not for use in marine environments.

electronics

- PathMaster is designed with solid state components and is rated for 10 years of continuous "normally on" use.
- Electrical connection is made via two flying leads.
- Standard product incorporates dip switches on rear of product allowing three levels of intensity. An optional line voltage dimmable driver is available on 120 VAC models. (see factory options)
- The line voltage dimmable driver requires a reverse-phase ELV dimming system.

power consumption

Current at dip switch setting (low, medium, high)
 12 VDC: 0.140 A, 0.330 A, 0.430 A
 120 VAC: 0.220 A, 0.465 A, 0.585 A
 120 VAC: 0.035 A, 0.065 A, 0.085 A
 120 VAC line voltage dimmable: 60 Hz, 0.072 A

- Standard Wet Location:
 Operating temperature range -31°F (-35°C) to 104°F (40°C).

lamps

- The PathMaster LED engine utilizes three high performance white LEDs combined with a solid-state integral driver circuit.
- PathMaster performs best when mounted 18" AFF. By utilizing multiple luminaires mounted on 10' centers, PathMaster will meet NFPA required 1 foot-candle average illumination standard.
- PathMaster incorporates a user selectable, three level intensity control or an optional line voltage dimmable driver (120 VAC models only).
- The PathMaster Series with white LEDs operates at 3500K nominal with a minimum CRI of 80. The amber LEDs operate at a nominal wave length of 600nm.

warranty

- Five-year full electronics warranty.



P/PH PathMaster LED die-cast step light

dimensions

PathMaster Series

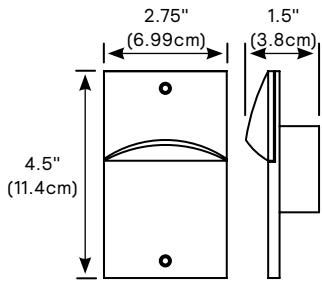

Horizontal PathMaster Series

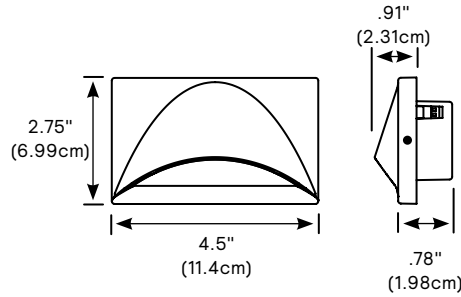

lumen output

The following data represents absolute lumen output in accordance with test method IESNA LM-79-08.

	Vertical, Lumens		
	Low	Med	High
12 VAC/VDC	57.1	123.5	156.0
120 VAC	65.5	123.8	156.0
120 VAC DIM		162.6	

performance

Meets Life Safety Code illumination standard; average of 1.0 FC, no point less than 0.1 FC, max to min ratio of 40:1. Assumes open space with no obstructions, mounting height: 18" and reflectances: 80/50/20. Analysis based on independently tested photometrics.

	Horizontal, Lumens		
	Low	Med	High
12 VAC/VDC	54.2	113.1	148.8
120 VAC	62.9	119.3	148.7
120 VAC DIM		128.7	

Wall Mounted 18" AFF High Setting

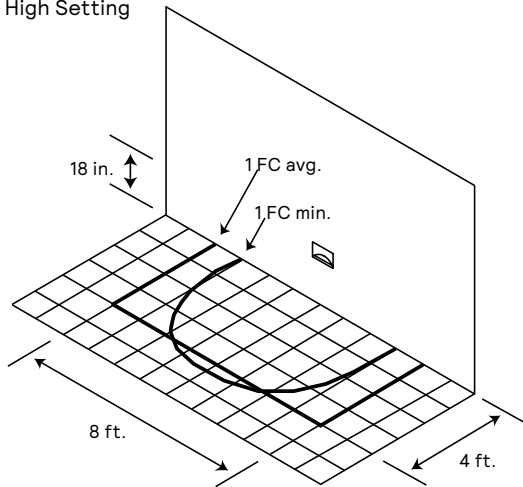

Test No.: ITL68144

Average initial footcandles = 3.11
 Maximum initial footcandles = 10.1
 Minimum initial footcandles = 0.4
 Maximum to minimum ratio = 25.25

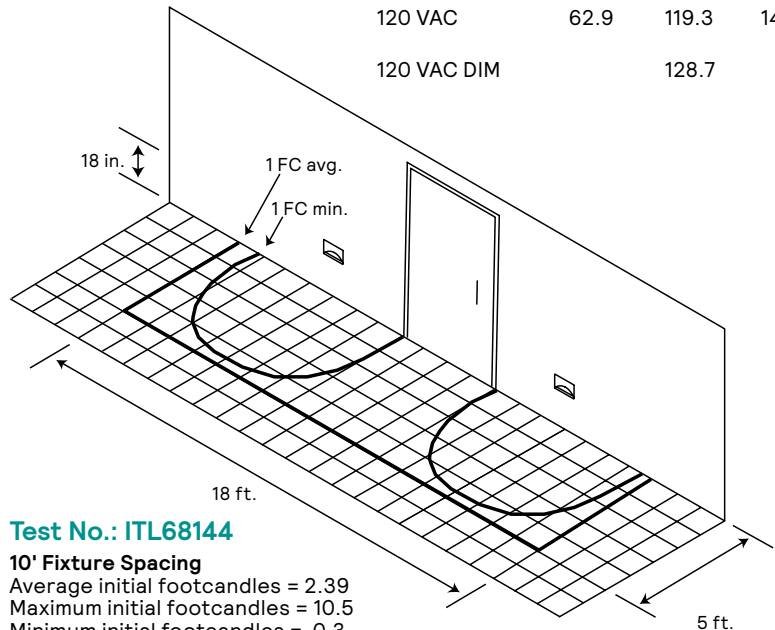

Test No.: ITL68144

10' Fixture Spacing
 Average initial footcandles = 2.39
 Maximum initial footcandles = 10.5
 Minimum initial footcandles = 0.3
 Maximum to minimum ratio = 35.00

Buy American Act of 1933 (BAA):

This product is manufactured in one of our US factories and, as of the date of this document, this product was considered a commercially available off-the-shelf (COTS) item meeting the requirements of the BAA. This BAA designation hereunder does not address (i) the applicability of, or availability of a waiver under, the Trade Agreements Act, or (ii) the "Buy America" domestic content requirements imposed on states, localities, and other non-federal entities as a condition of receiving funds administered by the Department of Transportation or other federal agencies. Prior to ordering, please visit www.signify.com/baa to view a current list of BAA-compliant products to confirm this product's current compliance.

