



SunStay Pro gen2 mini

VGP724 Hybrid

			6		5		i+	QR 21x21
				5mm 30Nm		6mm 16Nm	Service tag	QR 21x21
				3mm 1Nm			Scan me! DOWNLOAD	

			LEDs	IP66	IK09	IK07 PV panel	outdoor 	50Hz			4-10 m	220V 240V
			Ta Luminaire Operating Max 40°C min -20°C	Tc Battery Charging Max 60°C min 0°C	Tc Battery Discharging Max 60°C min -20°C							

The luminaire should be positioned so that prolonged staring into the luminaire at a distance closer than 0,384 m is not expected

Connect the battery for luminaire operation

1 	2 	3
--------------	--------------	--------------

- This luminaire must be installed by qualified personnel only
- Disconnect battery and panel before servicing
- Use gloves to install/service the luminaire
- Always follow this mounting instructions to fix the luminaire
- Never modify the luminaire nor the fixation locations for installation
- Risk of accident due to incorrect tightening torque



583 - 443000023002
2025-08-26
© Signify Holding
All rights reserved

i Dimensions

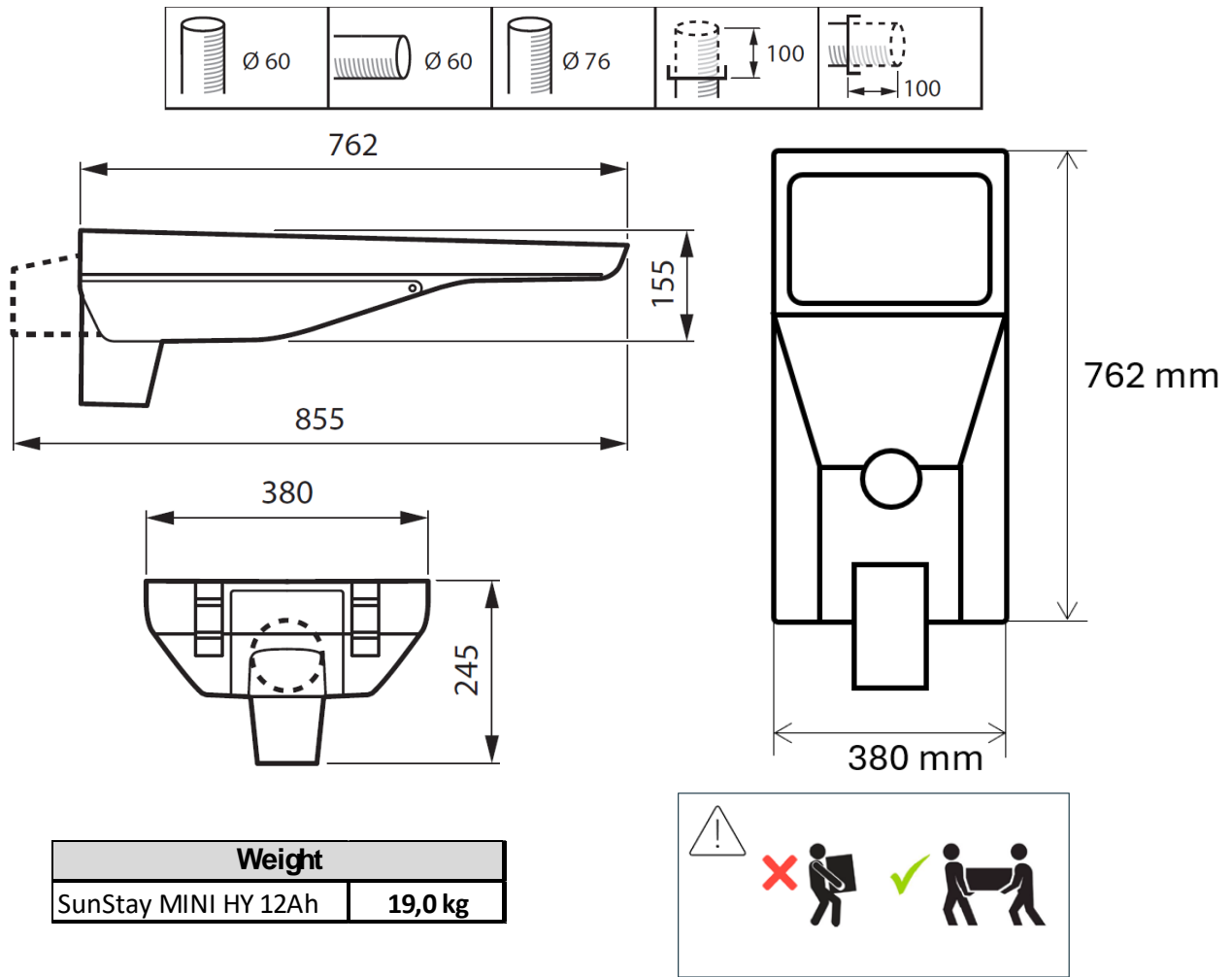

i S.Cx values

	From 0 to 15°	20°
S (m ²)	0,09	0,15
S.Cx (m ²)	0,07	0,09

i Energy efficiency class

LED CRI	70	70	80
LED CCT	4000K	3000K	3000K
Energy Eff. Class	D	D	E

Inrush Current 65A
Inrush Current Time width 0.8ms



For optimal performance of the luminaire contact your local SIGNIFY employee for solar sizing and configuration.

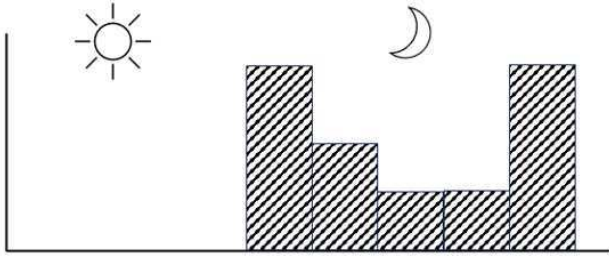

The installation of the luminaire is not recommended under these conditions:

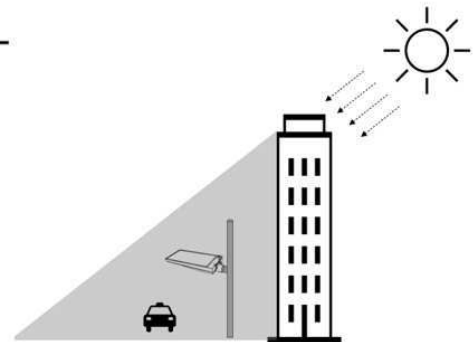
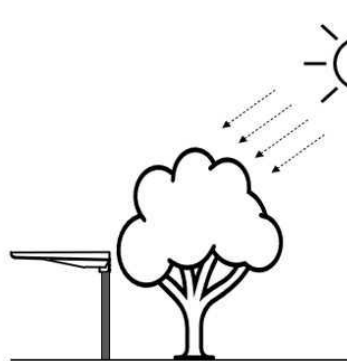
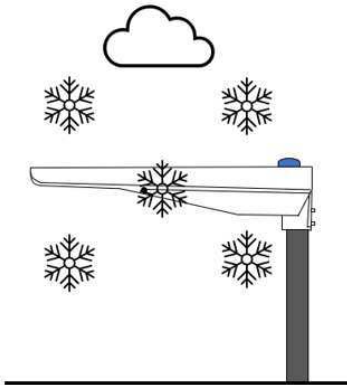

The luminaire performance and battery charging can be affected by external parameters.

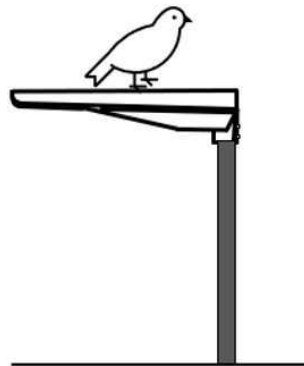
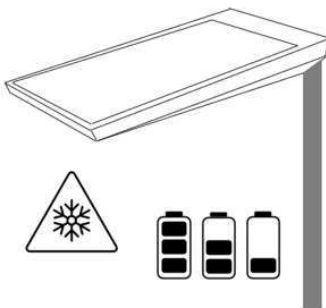

Additional photovoltaic vertical panels can be fixed to the pole. Contact your local SIGNIFY employee for further information.

911401822202

200Wp Vertical Panel Subsystem Vmpp 36V

912300058711

Kit for installation of the PV Vertical Panel

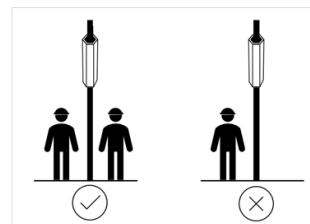
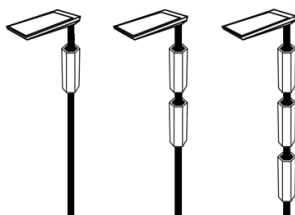

Please, refer to the specific *Vertical Panel Mounting Instructions* when ordering this option.

i Spigot fixation

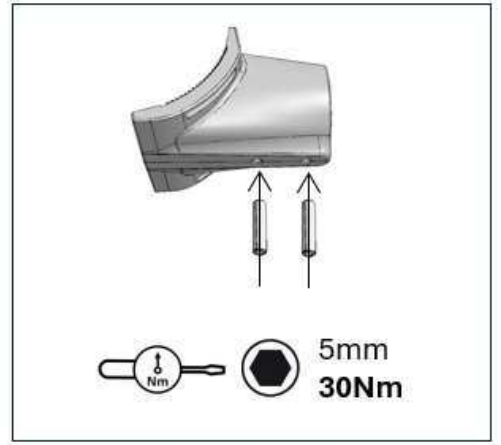
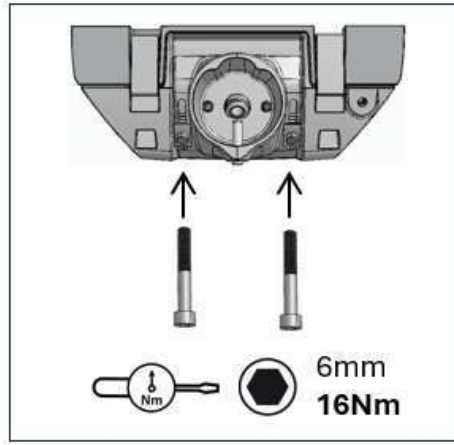
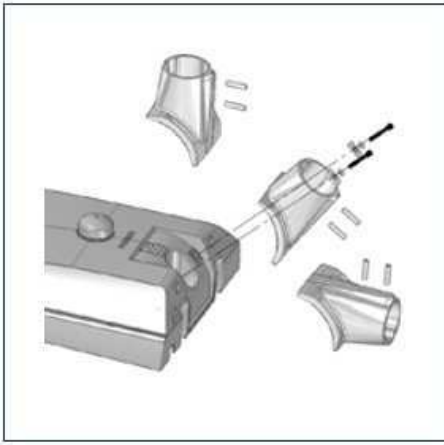

i Luminaire orientation

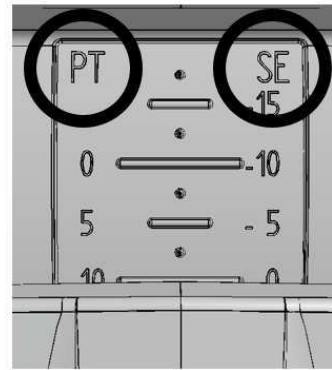
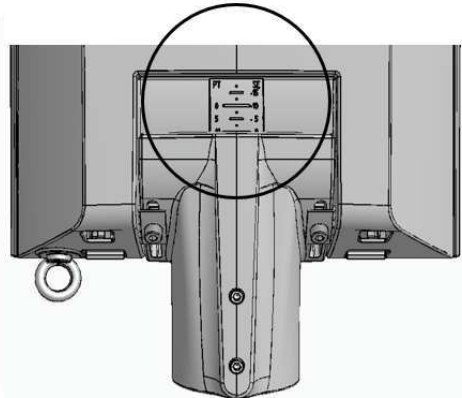

Post Top (PT):
Ø76mm or Ø60mm

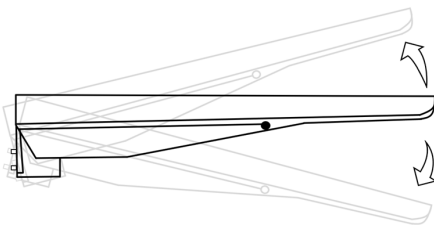

20°
17,5°
15°
12,5°
10°
7,5°
5°
2,5°
0°



Side Entry (SE):
Only Ø60mm

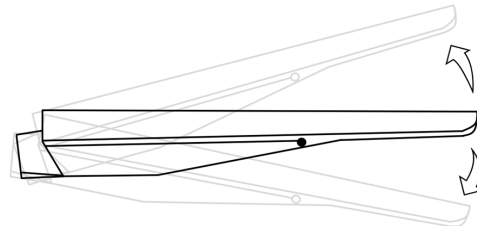

10°
7,5°
5°
2,5°
0°
-2,5°
-5°
-7,5°
-10°
-12,5°
-15°
-17,5°
-20°



Spigot into pole

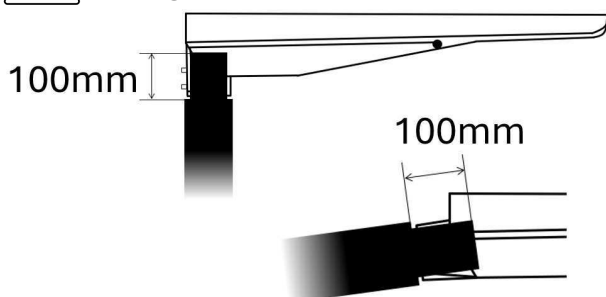

Open luminaire only if base is supported or if luminaire is installed on the pole

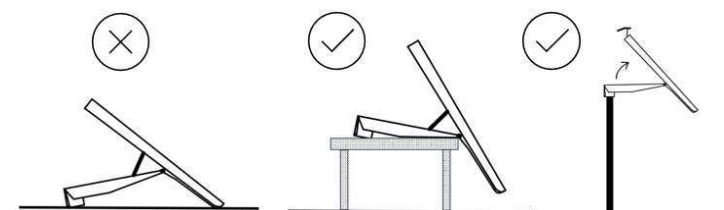



GB - Disconnect before servicing
 FR - Mettre hors tension avant intervention
 DE - Öffnen nur spannungsfrei
 NL - Stroom afsluiten voor onderhoud
 LT - Pirms apkopes atvienojiet no elektrības
 EE - Katkesta elektri toide enne valgusti hooldust/remonti
 PT - Desconecte antes de fazer a manutenção

DK - Frakobl, før service
 NO - Koble fra før service
 FI - Irrota pistoke ennen huolto
 CZ - Před servisem se odpojte
 TR - Servis yapmadan önce bağılantıyı kesin
 HR - Prije servisiranja isključite
 GR - Αποσυνδέστε πριν από τη συντήρηση
 BG - Изключете преди сервис
 RS - Отклучите пред обслуживанијем
 LV - Pirms apkopes atvienojiet to

IT - Togliere tensione prima di fare manutenzione
 SP - Desconectar antes de manipular
 SE - Bryt strömmen före lampbyte
 SK - Odpojit' pred údržbou
 SI - Pred servisiranjem izključite svetilko
 HU - Karbantartás előtt húzza ki a csatlakozót
 PL - Odłącz przed serwisowaniem
 RO - Deconectați-vă înainte de întreținere

i Mains connection

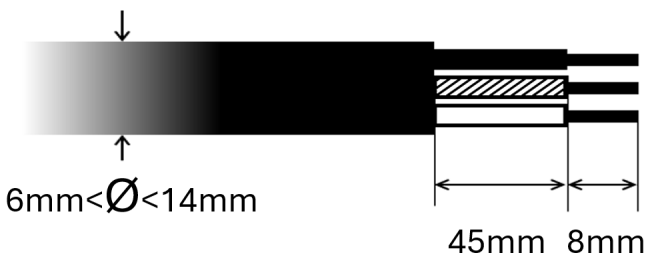
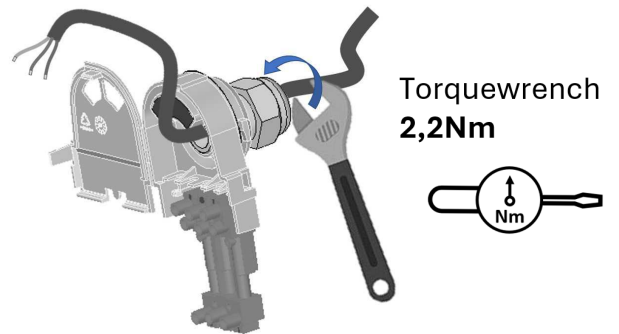
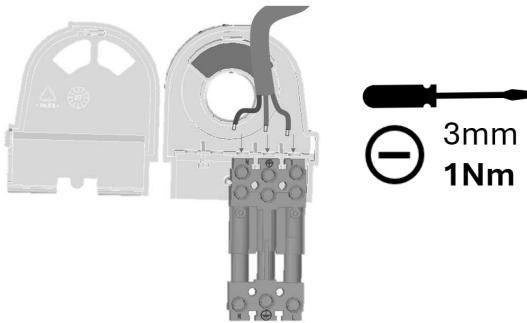
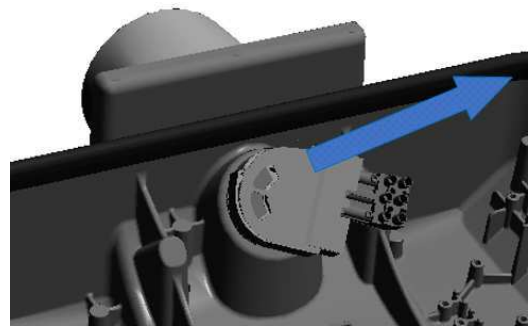
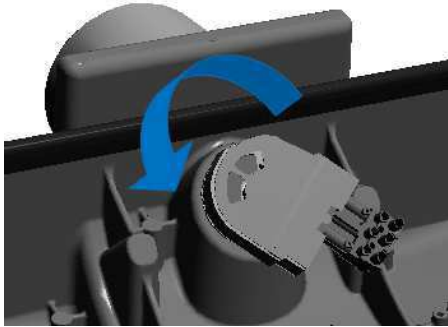

Surge Protection

SRG10 Conductive Pole
SRG10(E) Non-Conductive Pole

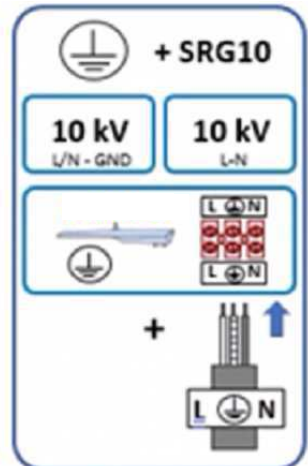
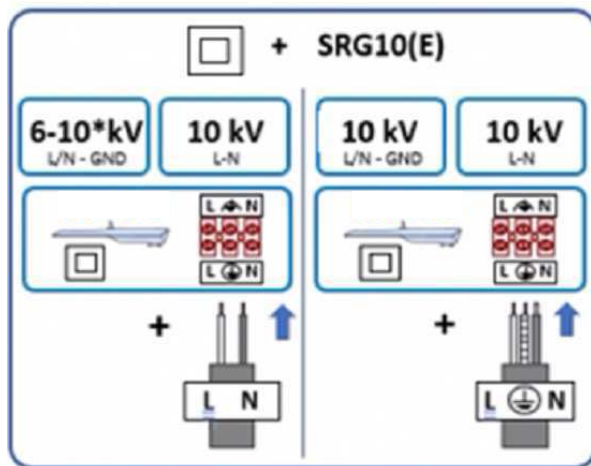
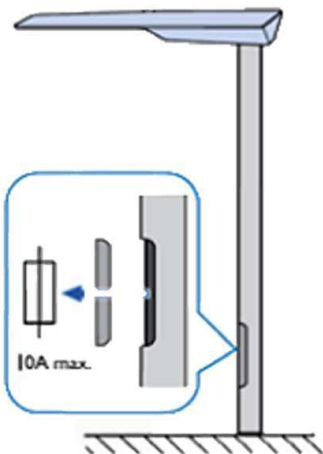
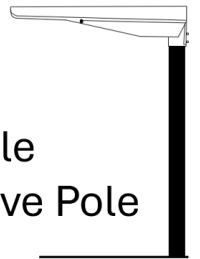

Sensors and type of luminaire

Luminaire	Version
No sensors	A
Bottom Sensor (OMS)	B
Top Sensor (OLC)	C
Top & Bottom Sensor (OLC & OMS)	D

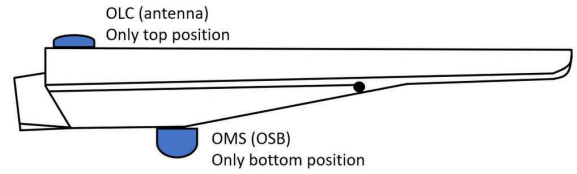

Optional: Top sensor: *Philips Outdoor Light Control (OLC)*

Description	Spare Part Code
AGP725 LLC7852/00 CT NODE ZHAGA DC EU4VF LG (Light Grey)	912300060696
AGP725 LLC7853/00 CT NODE ZHAGA DC EU4VF DG (Dark Grey)	912300060395

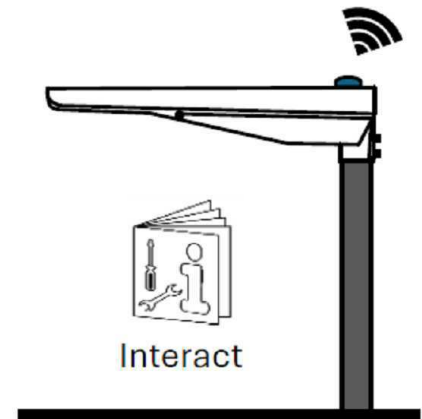
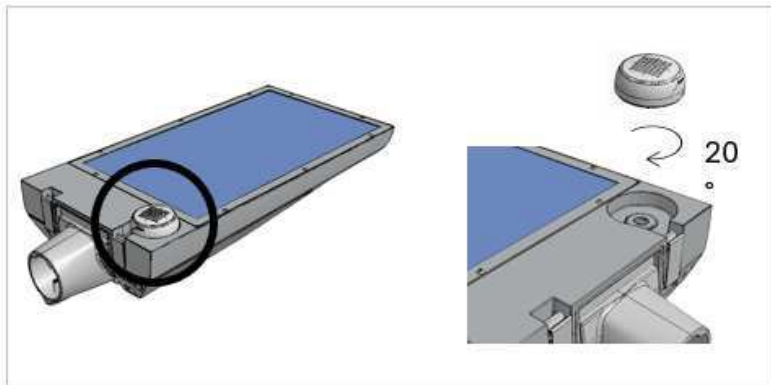

Optional: Bottom sensor: *Philips Outdoor Multi Sensor (OMS)*

Description	Spare Part Code
AGP725 LRI8135/00 OUTDOOR SENSOR BUNDLE	912300060396

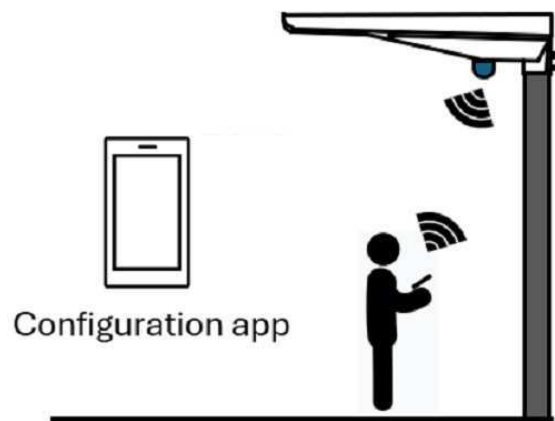
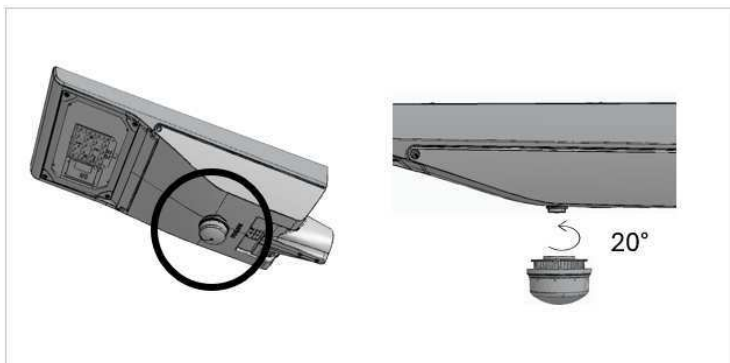

i The luminaire type A or B can be upgraded to C or D

Disconnect Battery and PV panel first before disconnecting or upgrading the product from A or B to C or D

Luminaire A or B: Charge Controller CC G5 is connected to BLE Bluetooth module

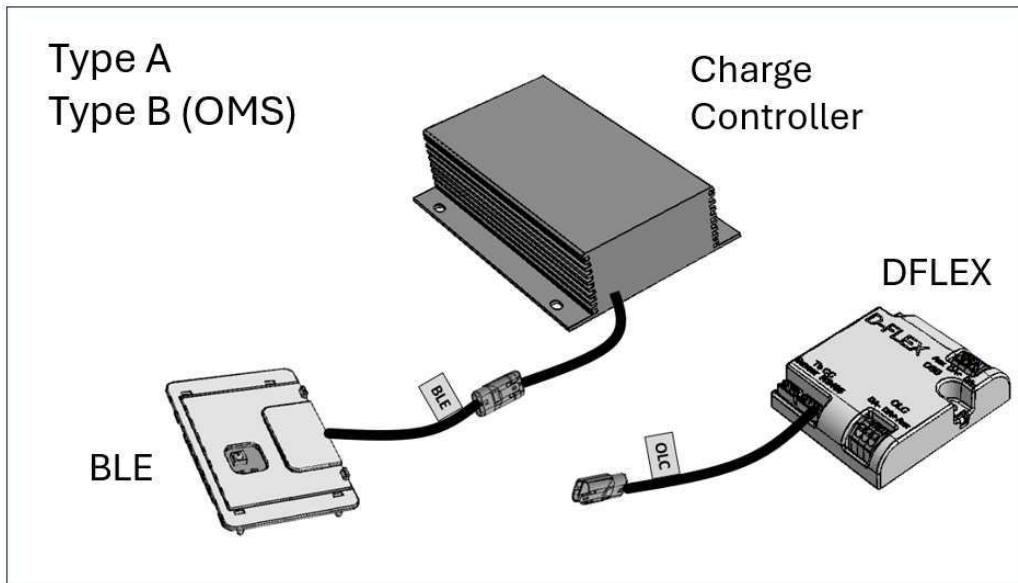

Luminaire C or D: Charge Controller CC G5 is connected to DFLEX

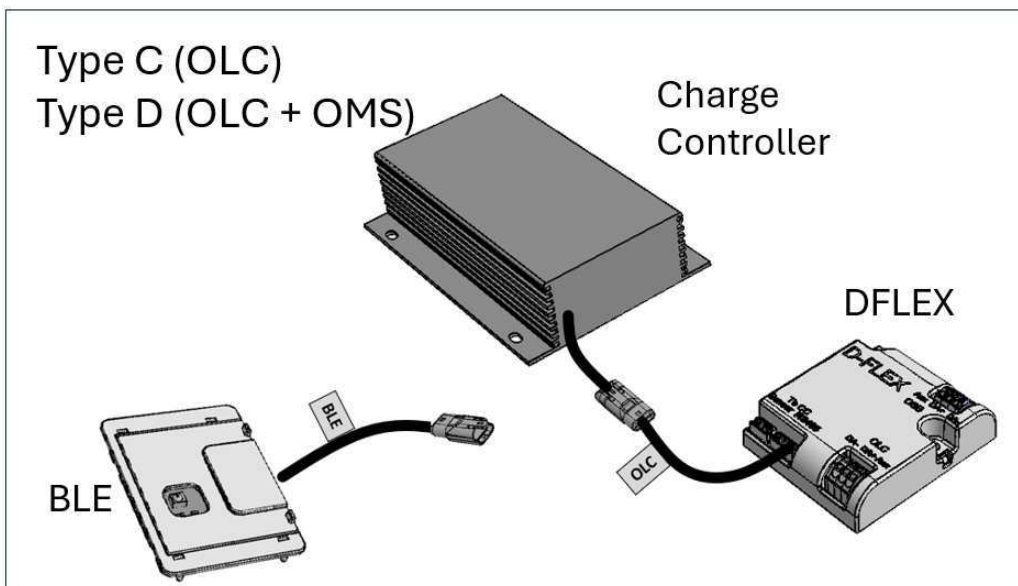

Contact your local SIGNIFY employee for further information





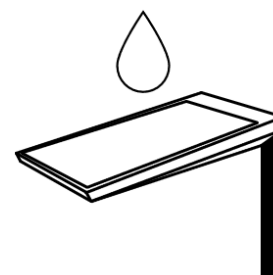



i Recommended luminaire cleaning

Cleaning interval months	Pollution category
12	High pollution
24	Low pollution
36	Clean environment

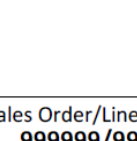

i Labelling

Watch out to the installation date. The battery is 70% level charged when leaving factory. Depending on storage time and ambient temperature, the battery can lose some charge.

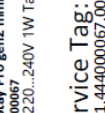
 SunStay Pro gen2 mini 12NC: 444000067	 SunStay Pro gen2 mini 12NC: 444000067	 SunStay Pro gen2 mini VGP724   System Power :1W A721.444000067.0001 12NC/SKU:444000067 EOC: EAN:	P.O. 444000067 QTY: 1 pce 444000067 P.O. 444000067 Made in Spain   Sales Order/Line 999999/99 Made in Spain 25W20 Signify, I.B.R.S.10461,5600 VB,NL	 Signify, I.B.R.S.10461,5600 VB,NL A721.444000067.0001.25W20  Signify, I.B.R.S.10461,5600 VB,NL A721.444000067.0001.25W20  Signify, I.B.R.S.10461,5600 VB,NL A721.444000067.0001.25W20
---	--	---	--	---

The labels in the luminaire contain a QR code. For any contact with SIGNIFY regarding the product, please scan the QR code and keep it for reference.

i Service Tag



1 Scan me!

2

3 Register me!



To get an overview of all spare parts, service instructions and battery charging, please refer to detailed instructions in the Service Manual available via the SIGNIFY Service tag apps (Android and iOS).



- GB** Storage, installation, use, operation and maintenance of the products needs to be performed exactly according the instructions in this manual and/or other instructions as may be provided by us to guarantee safe use of the product over its entire lifetime. Failure to adhere to these instructions will invalidate your entitlement to warranty. Bolts with indication of torque strength on the drawing need to be tightened using a calibrated torque wrench. Pre-assembled bolts need to be retightened again to the required torque specification to assure maximum strength over lifetime.
- SP** El almacenamiento, instalación, uso, funcionamiento y mantenimiento de este producto debe realizarse exactamente según las instrucciones de este manual, así como otras instrucciones que le proporcionemos con el fin de garantizar un uso seguro del producto durante toda su vida útil. Si no se cumplen estas instrucciones, la garantía quedará anulada. Los tornillos con indicación de par de apriete en el dibujo, deben apretarse con una llave dinamométrica calibrada. Los tornillos del acoplamiento premontados deben reapretarse de nuevo con la especificación de par de apriete necesaria para garantizar una solidez máxima durante toda la vida útil de la luminaria.
- PT** Para garantir uma utilização segura do produto durante a respetiva vida útil, o armazenamento, a instalação, a utilização, a operação e a manutenção dos produtos tem de ser efetuados exatamente de acordo com as instruções neste manual e/ou com outras instruções que possam ser fornecidas por nós. O incumprimento destas instruções irá invalidar o direito a garantia. Os parafusos com indicação do torque no esquema tem de ser apertados utilizando uma chave dinamométrica calibrada. Os parafusos pré-montados tem de ser novamente apertados de acordo com a especificação de torque necessário para garantir uma resistência máxima durante a vida útil.
- DE** Lagerung, Installation, Verwendung, Betrieb und Wartung der Produkte müssen genau nach den Anweisungen in dieser Anleitung und/oder anderen von uns zur Verfügung gestellten Anweisungen erfolgen, um eine sichere Verwendung des Produkts über seine gesamte Lebensdauer zu gewährleisten. Bei Nichtbeachtung dieser Hinweise erlischt Ihr Anspruch auf Gewährleistung. Schrauben mit Angabe der Drehmomente auf der Zeichnung müssen mit einem kalibrierten Drehmomentschlüssel angezogen werden. Vormontierte Schrauben müssen mit dem angegebenen Drehmoment nachgezogen werden, um eine maximale Festigkeit über die gesamte Lebensdauer zu gewährleisten.
- FR** Le stockage, l'installation, l'utilisation et la maintenance des produits doivent être effectués conformément aux instructions de ce manuel et / ou d'autres instructions que nous fournissons afin de garantir une utilisation sûre du produit pendant toute sa durée de vie. Le non-respect de ces instructions invalidera votre droit à la garantie. Les vis, dont les couples de serrage sont indiqués sur les schémas, doivent être serrés à l'aide d'une clé dynamométrique étalonnée. Les vis, préassemblés, doivent être resserrés à nouveau selon la spécification de couple de serrage requise afin d'assurer leur résistance maximale pendant toute leur durée de vie.
- IT** La conservazione, l'installazione, l'uso, il funzionamento e la manutenzione dei prodotti devono essere eseguiti esattamente in base alle istruzioni contenute nel presente manuale e / o in altra documentazione fornita da noi per garantire la sicurezza del prodotto per l'intera durata del suo utilizzo. La mancata osservanza di queste istruzioni invaliderà la garanzia. I bulloni con indicazione sull'intensità della coppia serraggio sul disegno devono essere serrati utilizzando una chiave dinamometrica calibrata. I bulloni pre-assemblati devono essere riserrati nuovamente secondo le specifiche di coppia richieste per assicurare la massima resistenza per tutta la durata.
- NL** Om een veilig gebruik van dit product gedurende zijn hele levensduur te garanderen, dient het opslaan, installeren, gebruiken, bedienen en onderhouden ervan exact te worden uitgevoerd in overeenstemming met de instructies in deze handleiding en/of andere door ons geleverde instructies. Niet opvolgen van deze instructies maakt uw garantieaanspraak ongedig. Bouten waarvan in de tekening het aanhaalkoppel is vermeld, dienen te worden vastgezet met behulp van een momentsleutel. Voor-geassembleerde bouten dienen opnieuw te worden aangehaald tot het vereiste koppel om maximale strekte gedurende de hele levensduur te waarborgen.
- DK** Opbevaring, installation, brug, betjening og vedligeholdelse af produkterne må kun udføres ifølge instruktionerne i denne vejledning og/eller eventuelle øvrige instruktioner fra Signify for at garantere sikker brug af produktet i hele dets levetid. Hvis disse instruktioner ikke følges, bortfalder produktgarantien. Bolte/skruer med angivet spændingsmoment på tegningen skal spændes med en indstillet momentnøgle. Færdigsamlede bolte/skruer skal efterspændes i henhold til det specificerede moment for at sikre maksimal fastgørelse i hele produktets levetid.
- SE** Förvaring, installation, användning, drift och underhall av produkterna måste utföras enligt instruktionerna i denna handbok och/eller andra instruktioner som kan tillhandahållas av oss för att garantera säker användning. Om instruktioner inte följs frångår man produktgarantin. Skruvar där vridmoment anges på ritningen måste dras åt med en kalibrerad skiftnyckel. Förmonterade skruvar måste dras åt igen med angivet vridmoment för att säkerställa högsta styrka under livslängden.
- NO** Oppbevaring, montering, bruk, drift og vedlikehold av produktene må utføres nøyaktig i samsvar med instruksjonene i denne handboken og/eller andre instruksjoner vi måtte gi for å garantere sikker bruk av produktet i hele dets levetid. Hvis instruksjonene ikke følges, bortfaller garantien. Bolter med angivelse av dreiemoment på tegningen må strammes med en kalibrert momentnøkkel. Ferdigmonterte bolter må strammes på nytt til pakrevd dreiemoment for å sikre maksimal styrke i hele produktets levetid.
- FI** Tuotteiden asennuksessa, käytössä ja huollossa on noudatettava tarkoin tässä käyttöoppaassa tai muissa toimittamissamme ohjemateriaaleissa annettuja ohjeita. Tämä varmistaa tuotteen turvallisen toiminnan koko sen käyttöajan ajan. Näiden ohjeiden noudattamatta jättäminen mitätöi kaikki oikeutetu takuukorvauksiin. Pultit, joille on asennusohjeessa ilmoitettu tietty kiristystiukkuus, on kiristettävä kalibroidulla momenttiavaimella. Esiasennetut pultit on kiristettävä ilmoitettuun kiristystiukkuuteen koko käyttöajan mittaisen kestävyuden varmistamiseksi.
- HU** Pêi uchovávaní, montáži, použivání a údržbi produktù je tøeba postupovat pøesní podle pokynù v této pøíruèce a dalších našich pøípadných pokynù, které zajíší bezpečné použivání produktù po celou dobu jejich životnosti. Když tyto pokyny dodržovat nebudete, přijdete o záruku. Šrouby, které mají na výkresu uveden uťahovací moment, je tøeba uťahovat zkalibrovaným momentovým klíèem. Pøedem namontované šrouby je tøeba dotáhnout požadovaným momentem, aby po dobu životnosti produktu držely na místì.
- PL** Przechowywanie, instalacja, użytkowanie, obsługa i konserwacja produktów musi odbywać się ściśle według wytycznych zawartych w niniejszej instrukcji i / lub w innych instrukcjach, które dołączamy, aby zagwarantować bezpieczne użytkowanie produktu przez cały okres eksploatacji. Nieprzestrzeganie tych instrukcji może spowodować utratę prawa do gwarancji. Śruby, przedstawione na rysunku wskazującym siłę momentu dokręcania, muszą być dokręcone za pomocą kalibrowanego klucza dynamometrycznego. Aby zapewnić maksymalną wytrzymałość w całym okresie użytkowania, wstępnie zamontowane śruby należy dokręcić zgodnie z wymaganą specyfikacją momentu dokręcenia.
- RO** Depozitarea, instalarea, utilizarea, operarea și întreținerea produselor trebuie să fie efectuate exact în conformitate cu instrucțiunile din acest manual și/sau cu alte instrucțiuni care pot fi furnizate de noi pentru a garanta utilizarea în siguranță a produsului, pe întreaga durată de viașă a acestuia. Nerespectarea acestor instrucțiuni vă va anula dreptul la garanție. Șuruburile care au cuplul de strângere indicat pe desen, trebuie să fie strânse cu ajutorul unei chei dinamometrice calibrate. Șuruburile preasamblate trebuie să fie strânse din nou la specificașia de cuplu cerută, pentru a asigura rezistenșă maximă pe întreaga durată de viașă.
- CZ** Pøi uchovávaní, montáži, použivání a údržbø produktù je tøeba postupovat pøesně podle pokynù v této pøíruèce a dalších našich pøípadných pokynù, které zajíší bezpečné použivání produktù po celou dobu jejich životnosti. Když tyto pokyny dodržovat nebudete, přijdete o záruku. Šrouby, které mají na výkresu uveden uťahovací moment, je tøeba uťahovat zkalibrovaným momentovým klíèem. Pøedem namontované šrouby je tøeba dotáhnout požadovaným momentem, aby po dobu životnosti produktu držely na místì.
- TR** Ürünlerin saklanması, kurulumu, kullanımı, çalıştırılması ve bakımı, ürünün kullanım ömrü boyunca güvenli kullanımının sağlanması amacıyla tam olarak bu kılavuzdaki ve/veya tarafımızdan sağlanan diğer talimatlara uygun biçimde gerçekleştirilmelidir. Söz konusu talimatlara uyulmaması, ürünü ilgili garanti hakkınızı geçersiz kılar. Teknik çizimdeyanında sıkma torku değeri belirtilen civatalar kalibre edilmiş bir tork anahtarı kullanılarak sıkılmalıdır. Önceden takılmış olarak gelen civataların da belirtilen tork değerine uygun biçimde yeniden sıkılması, kullanım ömrü boyunca maksimum dayanıklılığın sağlanması açısından önemlidir.
- BG** Съхранението, инсталирането, употребата, експлоатацията и поддръжката на продуктите трябва да се извършват точно в съответствие с указанията в това ръководство и / или други инструкции, които могат да бъдат предоставени от нас, за да се гарантира безопасна употреба на продукта през целия му експлоатационен живот. Неспазването на тези указания ще обезсили Вашето право на гаранция. Болтовете с индикация за силата на въртящия момент на чертежа трябва да бъдат затегнати с помощта на калибриран гаечен ключ. Предварително сглобените болтове трябва да бъдат отново затегнати до изискваната спецификация на въртящия момент, за да осигурят максимална якост по време на експлоатационния живот.



GR Η αποθήκευση, η εγκατάσταση, η χρήση, η λειτουργία και η συντήρηση των προϊόντων πρέπει να γίνεται ακριβώς σύμφωνα με τις οδηγίες του παρόντος εγχειριδίου ή / και τις άλλες οδηγίες που ενδεχομένως να παρασχεθούν, προκειμένου να είναι εγγυημένη η ασφαλής χρήση του προϊόντος για ολόκληρη τη διάρκεια ζωής του. Η μη εφαρμογή αυτών των οδηγιών θα ακυρώσει τα δικαιώματά σας στο πλαίσιο της εγγύησης. Οι βίδες με ένδειξη τιμής ροπής σύσφιξης στο σχέδιο θα πρέπει να σφίχθουν με τη χρήση ενός βαθμονομημένου ροποκλειδού. Οι προ-συναρμολογημένες βίδες πρέπει να σφίχθουν και πάλι ης την απαιτούμενη τιμή ροπής σύσφιξης, προκειμένου να διασφαλιστεί η μέγιστη ισχύς σε όλη τη διάρκεια ζωής.

RS Чтобы гарантировать безопасное использование этого изделия на протяжении всего соответствующего срока службы, его хранение, установку, использование, эксплуатацию и обслуживание необходимо осуществлять в точном соответствии с приведенными в настоящем руководстве инструкциями и (или) иным инструкциями, которые могут быть предоставлены нами. Несоблюдение этих инструкций приведет к потере прав на гарантию. Болты, для которых на чертеже указан крутящий момент, необходимо затягивать калиброванным динамометрическим ключом. Для обеспечения максимальной прочности изделия в течение всего срока службы болты, завинченные в ходе предварительной сборки, необходимо подтянуть до указанного момента.

SK Uskladnenie, inštalácia, používanie a údržba produktov je potrebné postupovať presne podľa pokynov v manuáli a/alebo iných nami poskytnutých pokynov, ktoré zaisťujú bezpečné používanie produktu počas celej doby životnosti. Nedodržaním týchto pokynov sa ruší záruka. Skrutky s naznačenou silou utiahnutia, musia byť ťažované kalibrovaným momentovým kľúčom. Vopred namontované skrutky musia byť znovu utiahnuté podľa požadovanej špecifikácie, aby komponenty držali na mieste počas celej životnosti.

HR Porhanjivanje, instaliranje, uporaba, korištenje i održavanje proizvoda treba se vršiti točno u skladu s uputama u ovom priručniku i/ili s drugim uputama osiguranim s naše strane kako bi se jamčila sigurna uporaba proizvoda kroz cijeli radni vijek. Nepoštivanje ovih uputa poništava vaše pravo na jamstvo. Vijci s indiciranim momentom zatezanja na nacrtu trebaju biti učvršćeni korištenjem zateznog alata s kalibriranim momentom zatezanja. Također i već učvršćeni vijci trebaju biti dotežani do specificiranog zateznog momenta kako bi se osigurala učvršćenost tijekom cijelog radnog vijeka.

LT Produktų saugojimas, montavimas, naudojimas, eksploatavimas ir priežiūra turi būti atlikti tiksliai pagal instrukcijas, pateiktas šiame vadove ir (arba) kitas instrukcijas, kurias mes galime pateikti, kad garantuotume saugų gaminio naudojimą per visą jo eksploatavimo laiką. Jei nesilaikysite šių instrukcijų nurodymų bei reikalavimų, jūsų teisė į garantiją bus panaikinta ir nebegalios. Varžtai, nurodantys sukimo momento stiprumą brėžinyje, turi būti užveržti naudojant kalibruotą sukimo momento veržliaraktį. Iš anksto sumontuotus varžtus reikia vėl priveržti iki reikiamo sukimo momento, kad būtų užtikrintas maksimalus tvirtumas per visą eksploatavimo laiką.

LV Izstrādājumu uzglabāšana, uzstādīšana, lietošana un apkope jāveic precīzi saskaņā ar šajā rokasgrāmatā sniegtajām instrukcijām un / vai citām instrukcijām, kuras mēs varam piedāvāt, lai garantētu produkta drošu lietošanu visā tā darbības laikā. Neievērojot šos norādījumus, jūsu tiesības uz garantiju tiek anulētas. Bultskrūves ar norādi uz griezes stiprumu zīmējumos jābūt pieskrūvētam izmantojot kalibrētu griezes atslēgu. Iepriekš samontētās skrūves ir atkal jāpievelk līdz vajadzīgajai griezes specifīkacijai, lai nodrošinātu maksimālu pieguli visā ekspluatācijas laikā.

EE Toodete ladustamine, paigaldamine, kasutamise, käitamine ja hooldus tuleb läbi viia täpselt vastavalt selle juhendi juhistele ja/või muudele meie poolt pakutavatele juhistele, et tagada toote ohutu kasutamise kogu selle toote eluaja jooksul. Nende juhiste mittejärgimine kaotab teie õiguse garantiile. Poldid, millel on joonisel toodud pöördemomendi tugevus, tuleb pingutada kalibreeritud pöördemoment mutrivõtme abil. Eelnevalt kinnitatud poldid tuleb uuesti pingutada vastavalt nõutavale pöördemomendi spetsifikatsioonile, et tagada maksimaalne kinnituse tugevus kogu eluea jooksul.

SI Skladiščenje, namestitev, uporaba, delovanje in vzdrževanje izdelkov mora biti natančno izvedeno v skladu z navodili in / ali drugimi navodili za zagotovitev vame uporabe izdelka skozi celotno življenjsko dobo. V primeru neupoštevanja teh navodil, se lahko razveljavi pravica do garancije. Vijake, ki imajo označen navor, je potrebno zategniti s kalibriranim navornim ključem. Vijake, ki so že sestavljeni, je potrebno znova priviti v skladu z zahtevanim navorom, da je zagotovljena maksimalna moč skozi življenjsko dobo.



GB The light source contained in this luminaire and the external flexible cable shall only be replaced by the manufacturer or his service agent or a similar qualified person.

SP La fuente de luz y el cable flexible exterior incluidos en esta luminaria sólo podrán ser sustituidos por el fabricante o su agente de servicio o una persona cualificada.

PT A fonte de luz e o cabo flexível externo contido nesta luminária só serão substituídos apenas pelo fabricante ou o seu agente de serviços ou uma pessoa qualificada similar.

DE Die in dieser Leuchte enthaltenen Lichtquelle und das externe flexible Kabel dürfen nur durch den Hersteller oder seinen Kundendienst oder eine ähnlich qualifizierte Person ersetzt werden.

FR La source de lumière contenue dans ce luminaire et le câble externe souple ne doivent être remplacés que par le fabricant, son agent de service ou une personne qualifiée.

IT La sorgente di luce e il cavo flessibile contenuti in questo apparecchio potranno essere sostituiti solo dal costruttore, dal suo personale addetto all'assistenza tecnica o ugualmente qualificato.

NL De lichtbron en de externe flexibele kabel in dit armatuur mogen alleen worden vervangen door de fabrikant of zijn service agent of een soortgelijk gekwalificeerd persoon.

DK Lyskilden og det eksterne fleksible kabel, der er indeholdt i dette armatur, må kun udskiftes af fabrikanten eller hans serviceværksted eller en tilsvarende kvalificeret person.

SE Ljuskällan och den externa flexibla kabeln i denna armaturen får endast bytas ut av tillverkaren eller dennes serviceombud eller liknande behörig person.

NO Lyskilden og den eksterne fleksible kabelen i denne armaturen skal bare skiftes ut av produsenten eller serviceverkstedet eller en tilsvarende kvalifisert person.

FI Valonlähde ja ulkoinen joustava kaapeli sisältyvät valaisimen saa vaihtaa vain valmistaja tai valtuutettu huoltoliike tai muu ammattitaitoinen.

HU lámpatestben található fényforrás és a külső rugalmas kábelt csak a gyártó, a gyártóval szerződött cég vagy megfelelő képesítéssel rendelkező szakember cserélheti ki.

PL Źródła światła zawarte w oprawie i zewnętrzny elastyczny przewód powinny być wymieniane wyłącznie przez producenta, przedstawiciela jego serwisu lub wykwalifikowaną osobę.

RO Sursa de lumină conținută în acest corp de iluminat și cablul flexibil extern trebuie înlocuită doar de către producător sau agent de service sau de o persoană calificată similară.

CZ Světelný zdroj obsažený v tomto svítidle a externí flexibilní kabel se nahrazují pouze výrobcem nebo jeho servisním zástupcem nebo podobně kvalifikovanou osobou.

TR Bu armatürde bulunan ışık kaynağı ve harici esnek kablo yalnızca üretici veya servis temsilcisi veya benzer bir yetkili kişi tarafından değiştirilebilir.

HR Izvor svjetla sadržan u ovom svjetiljke i vanjski fleksibilni kabel ce se zamijeniti samo proizvođač ili njegov servisera ili sličnog stručne osobe.

GR Η πηγή φωτός που περιέχονται σε αυτό το φωτιστικό και το εξωτερικό εύκαμπτο καλώδιο θα πρέπει να αντικατασταθεί μόνο από τον κατασκευαστή ή τον αντιπρόσωπο συντήρησης αυτού ή έναν παρόμοιο ειδικευμένο άτομο.

BG Източникът на светлина се съдържа в този осветително тяло и външния гъвкав кабел, се заменя само от производителя или негов сервисен агент или подобно квалифицирано лице.

RS Источник света, содержащийся в этом светильнике, и внешний гибкий кабель должны заменяться только производителем, его сервисным агентом или аналогичным квалифицированным лицом.

SK Svetelný zdroj obsiahnutý v tomto svítidle a externý flexibilný kabel by mal byť vymenený len výrobcem alebo jeho servisným zástupcom alebo podobne kvalifikovanou osobou.

LT Šiame šviestuve esantį šviesos šaltinį ir išorinis lankstus kabelis gali pakeisti tik jo gamintojas arba jo serviso atstovas arba atitinkamas kvalifikuotas asmuo.

LV Gaismas avotu, ko satur šis gaismeklis un ārējais elastīgais kabelis, var samainīt tikai ražotājs, vai tā servisa pārstāvis vai līdzīgi kvalificēta persona.

EE Selles valgustus sisalduvat valgusalikat ja väline painduvat kaablilt saab asendada ainult tootja või tema teenindusagent või samase kvalifitseeringuga isik.

SI Svetlobni vir v svetilki in zunanji prilagodljivi kabel lahko zamenja samo proizvajalec, njegov zastopnik ali strokovno usposobljena oseba.



© 2025 Signify Holding

All rights reserved. The information provided herein is subject to change, without notice. Signify does not give any representation or warranty as to the accuracy or completeness of the information included herein and shall not be liable for any action in reliance thereon. The information presented in this document is not intended as any commercial offer and does not form part of any quotation or contract, unless otherwise agreed by Signify. All trademarks are owned by Signify Holding or their respective owners.

Signify Holding
The Netherlands