

ATTENTION:

CAUTION ON (2) LIGHT MODEL ONLY
 FIXTURES WILL BE MOUNTED OPPOSITE
 EACH OTHER AND IN LINE WITH THE CENTERS
 OF ONE ANCHOR ROD AND THE POST
 AS SHOWN.

STREET SIDE

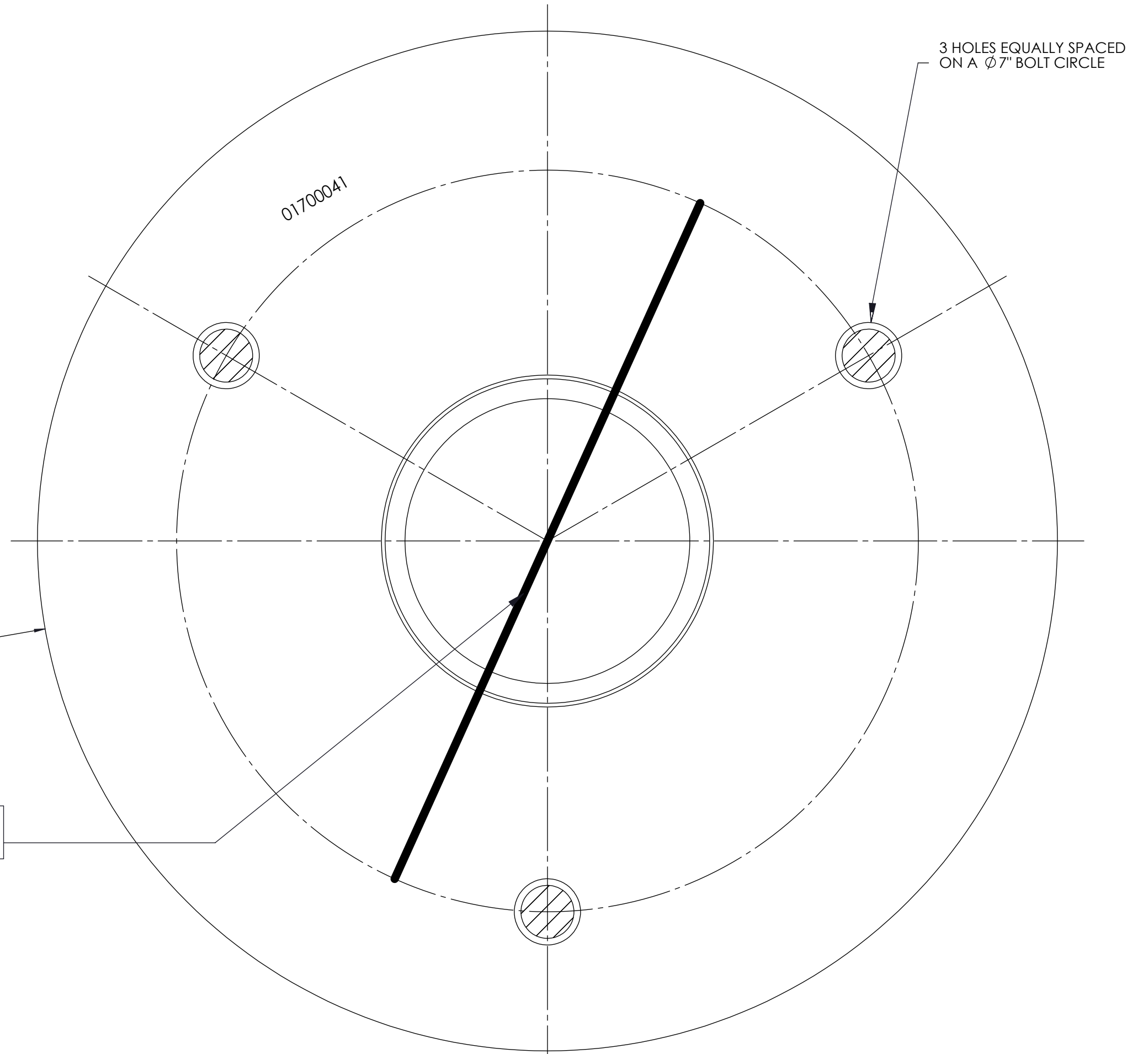
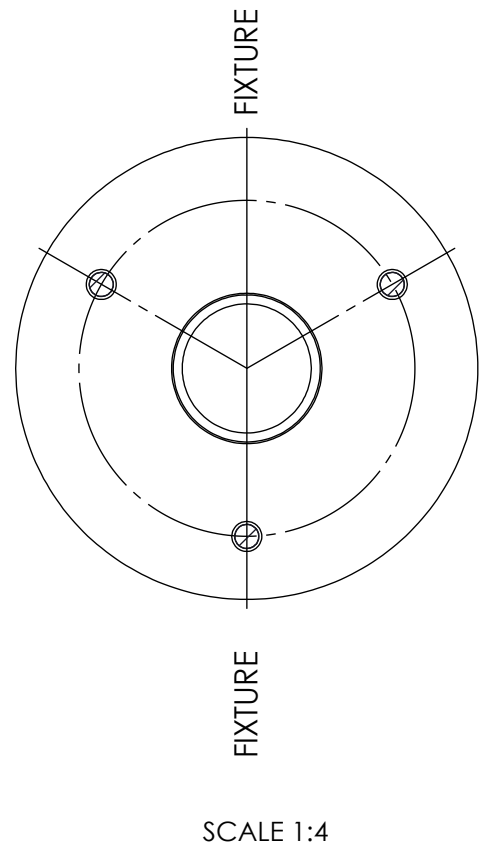

HAND HOLE

HOUSE SIDE

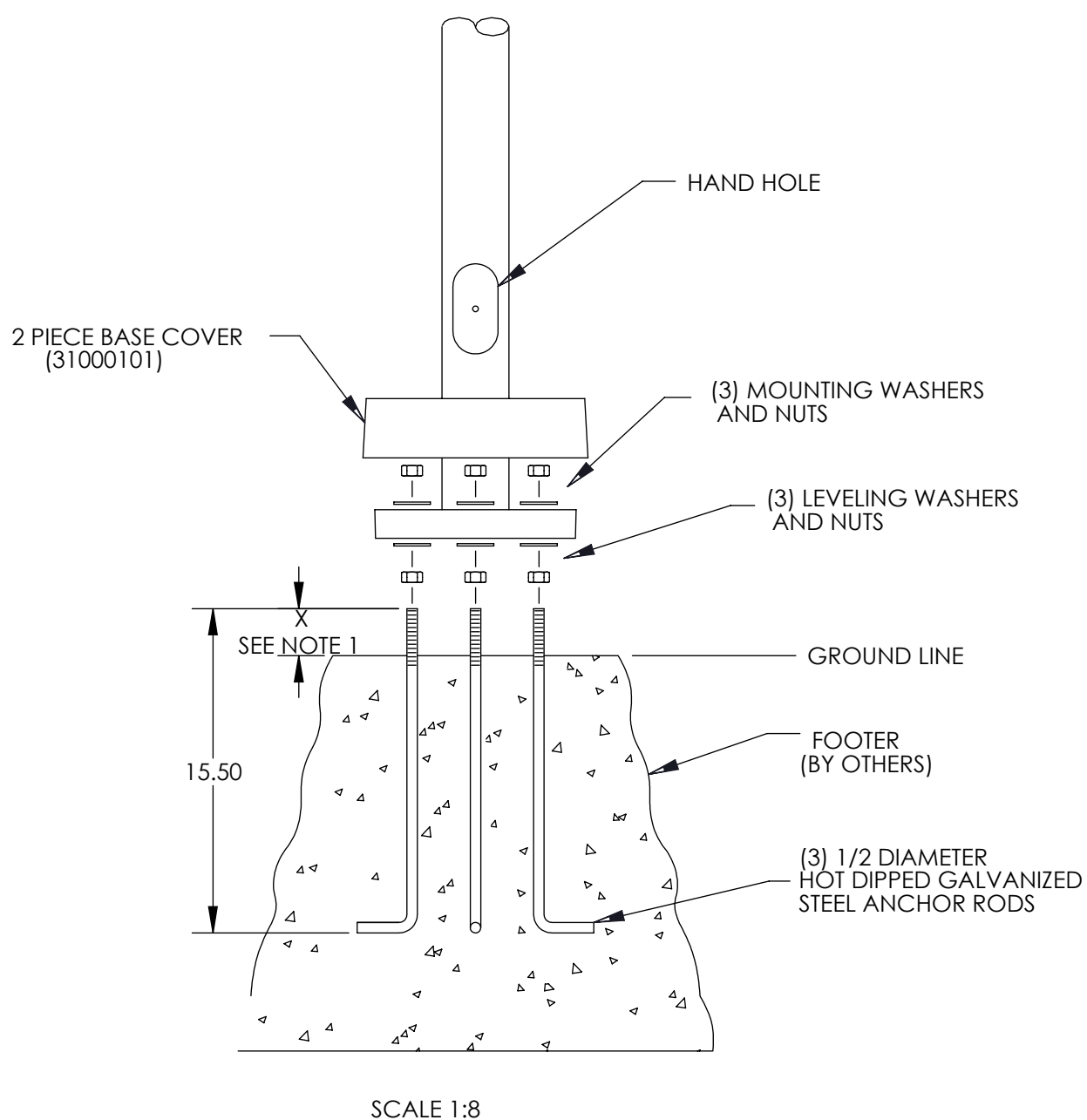

- NOTES:
1. STRONGLY RECOMMENDED TO USE LEVELING NUTS TO MOUNT THE POST BASE. IF FOUNDATION IS NOT LEVEL, INCREASE "X" DIMENSION ACCORDINGLY WHEN USING LEVELING NUTS WITH WASHERS.
 X = 2 1/2" MINIMUM WITH LEVELING NUTS
 X = 2 3/4" MINIMUM WITHOUT LEVELING NUTS
 2. IF USING GROUTING TO CONCEAL GAP BETWEEN BASE AND FOUNDATION, ALLOW FOR WATER DRAINAGE.

	CONFIDENTIAL: This drawing is confidential and proprietary to Signify Holdings and may not be reproduced in whole or in part without the express written consent of Signify Holdings. © 2018 Signify Holdings. All rights reserved.		TITLE: TEMP.AR,150
	UNLESS OTHERWISE SPECIFIED: *ALL DIMENSIONS ARE IN INCHES. *ALL THREADS ARE UNC-2B OR UNF-2B AFTER COATING. *ALL THREADS ARE TO BE VERIFIED WITH A THREAD GAGE.	DRAWN BY: C. CARR CHECKED BY: B. DORON APPR BY: E. HADDAD	DATE: 4/9/99 DATE: 8/4/09 DATE: 4/9/99
* DO NOT SCALE THIS DRAWING *		EF-04-01-11 Rev.09 SCALE 1:1 SHEET 1 OF 1	PART NO: T01700041