

EH	D	06-026	KAR	2/20/06
WHD	E	08-039	JGB	8/21/08
WHD	F	09-065	ALD	7/30/09
APPR	REV	ISO DOC	BY	DATE

PART NO. T01000345

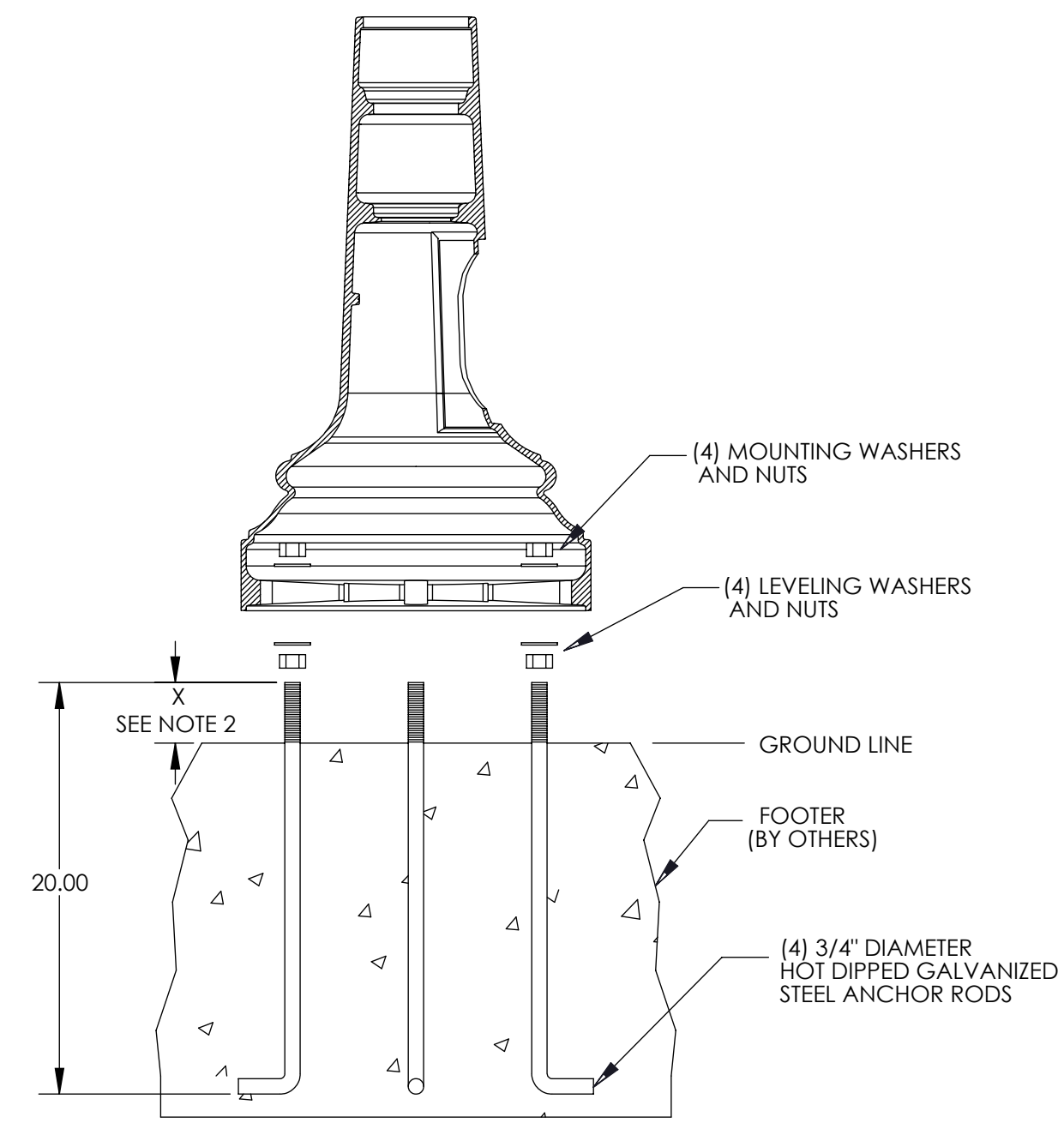
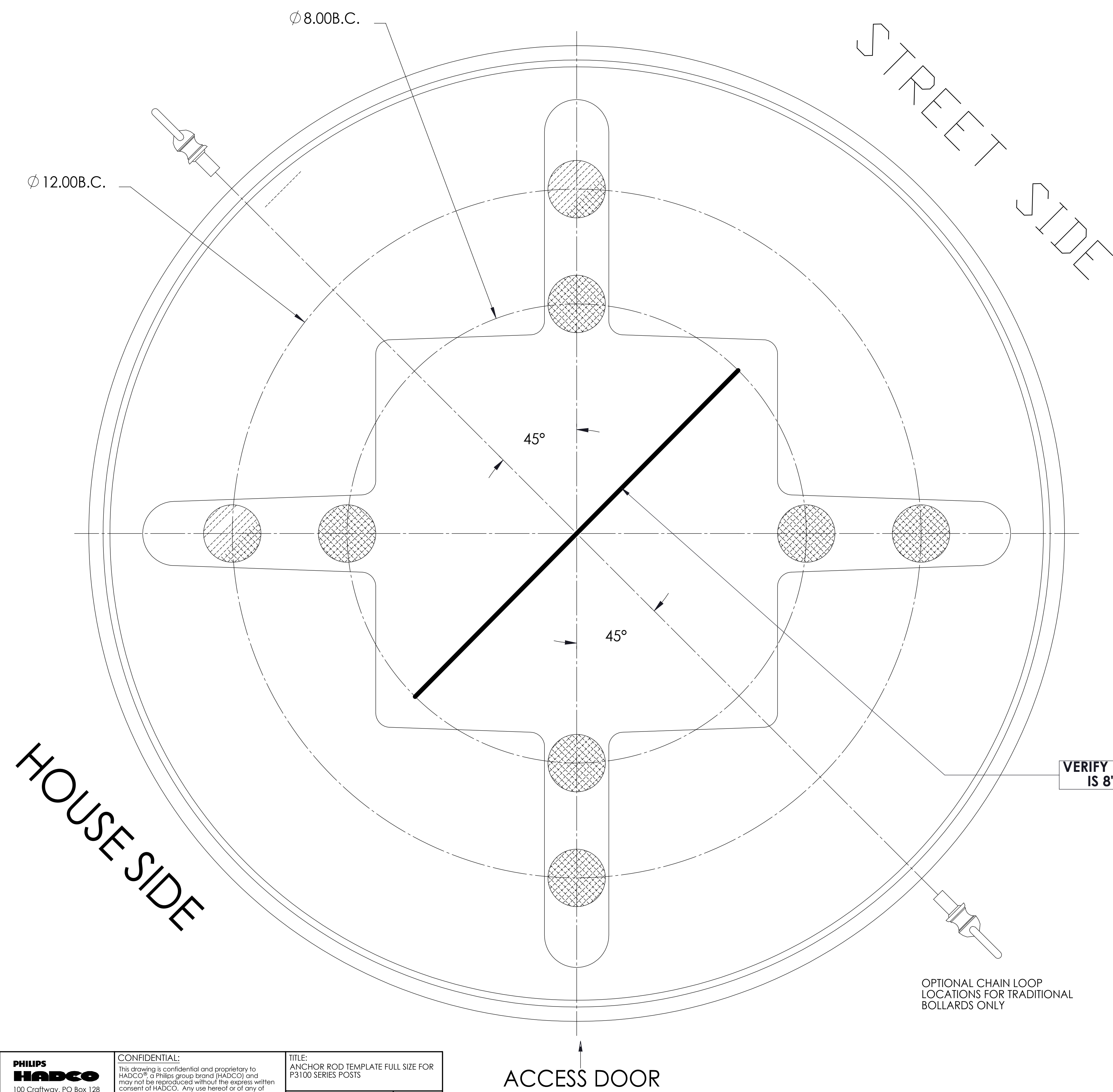

- NOTES:
- SUGGESTED BOLT CIRCLE: 12" DIAMETER
 MAXIMUM BOLT CIRCLE: 12" DIAMETER
 MINIMUM BOLT CIRCLE: 8" DIAMETER
 - HADCO STRONGLY RECOMMENDS USING LEVELING NUTS TO MOUNT THE POST BASE. IF FOUNDATION IS NOT LEVEL, INCREASE "X" DIMENSION ACCORDINGLY WHEN USING LEVELING NUTS WITH WASHERS.

 X = 3" WITH LEVELING NUTS
 X = 2 1/4" WITHOUT LEVELING NUTS
 - IF USING GROUTING TO CONCEAL GAP BETWEEN BASE AND FOUNDATION, ALLOW FOR WATER DRAINAGE.

WARNING
NOT TO SCALE
CONSULT FACTORY FOR FULL SIZE TEMPLATE.

OPTIONAL CHAIN LOOP LOCATIONS FOR TRADITIONAL BOLLARDS ONLY

VERIFY BOLD LINE IS 8" LONG

HOUSE SIDE

STREET SIDE

ACCESS DOOR

PHILIPS HADCO 100 Craftway, PO Box 128 Littlestown, PA 17340-0128 Phone: 717-359-7131 Fax: 717-359-9515 www.hadco.com	CONFIDENTIAL: This drawing is confidential and proprietary to HADCO®, a Philips group brand (HADCO) and may not be reproduced without the express written consent of HADCO. Any use hereof or of any of the information or detail herein shall be for the sole benefit of HADCO. © 2009 HADCO®, a Philips group brand	TITLE: ANCHOR ROD TEMPLATE FULL SIZE FOR P3100 SERIES POSTS
	DRAWN BY: C. CARR DATE: 11/16/00	DWG NO.: T01000345 SIZE: D
	CHECKED BY: B. DORON DATE: 7/30/09	MATERIAL: 22 X 34 WHITE BOND PAPER
	APPR BY: M. N. BANKERT DATE: 6/15/01	* DO NOT SCALE THIS DRAWING *
<small>UNLESS OTHERWISE SPECIFIED: *ALL DIMENSIONS ARE IN INCHES. *ALL THREADS ARE UNC-2B OR UNF-2B AFTER COATING. *ALL THREADS ARE TO BE VERIFIED WITH A THREAD GAGE.</small>	<small>EF-04-01-11 Rev.08 SCALE: NTS SHEET 1 OF 1</small>	

PART NO. T01000345