

Project: \_\_\_\_\_

Location: \_\_\_\_\_

Cat.No: \_\_\_\_\_

Type: \_\_\_\_\_

Lamps: \_\_\_\_\_ Qty: \_\_\_\_\_

Notes: \_\_\_\_\_

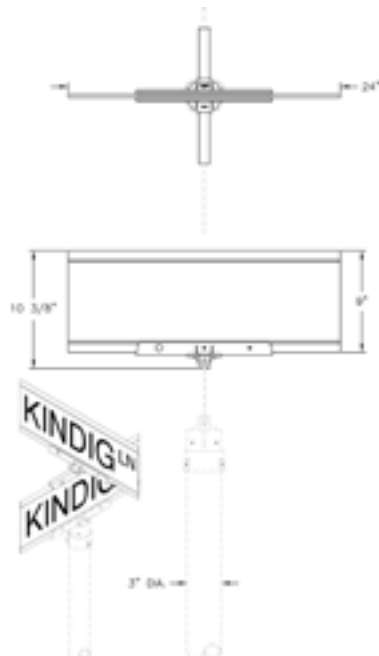

### Ordering Guide

Example: 200-EBX V ABS A B WHT 12

Product Code	200-EBX	Street Sign
<b>Lettering</b>	V	Vinyl
<b>Finish</b>	ABS ACP ARD ASI BLK BRN BRZ FGN GRA IRN RBZ SRT VBZ VCP VGN VTC WBZ WHT	Antique Brass Antique Copper Antique Red Antique Silver Black Brown Bronze Forest Green Granite Ironstone Rustic Bronze Shadow Rust Verde Bronze Verde Copper Verde Vintage Copper Weathered Bronze White
<b>Print</b>	A B N	Single Sided Double Sided None
<b>Vinyl Lettering Style</b>	B	Block *1
<b>Letter Color</b>	WHT	White
<b>Wording</b>	12	Spaces (12)

\*1 Vinyl Lettering Style Only

### Specifications

**CONSTRUCTION:**

Extruded aluminum 24" x 9" sign with engineer grade reflective green vinyl both sides, attached to cast aluminum post fitter. Cast aluminum cross arm bracket. (Sign has 23" x 7" lettering area on both sides.)

**FINISH:**

Resilient TGIC thermoset polyester powdercoat paint is electrostatically applied to every fixture. Specially formulated for Philips Outdoor Lighting, it provides UV protection, and the highest temperature rating in the industry. In addition to the standard color choices shown, a spectrum of custom colors is available.

**MOUNTING:**

To mount 200-EBX top sign assembly, Customer must order 200-EB3 bottom sign and fitter assembly.

**WARRANTY:**

Three-year limited warranty.

# 200-EBX Accessories

## Street sign

### Specifications

---

**Height:**

10 3/8"

**Width:**

24"

