

System Overview

These instructions review how to install FloatPlane wall mount fixtures. 4ft, 6ft and 8ft modules can be installed as individual standalone units, or they can be joined together to create continuous runs. The graphics below show the components required to install a typical run of FloatPlane wall mount fixtures.

IMPORTANT: Read all instructions before beginning installation.

FloatPlane Wall Endcap Kits

- L or R specific Endcap
- Common Foam gasket
- #8-32 x 1/2" screws (x2)
- Plastic rivet

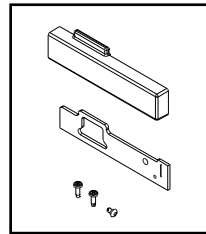

Wall Power Kit

- J-box cover
- Strain relief



Wall Mount Brackets (typ)

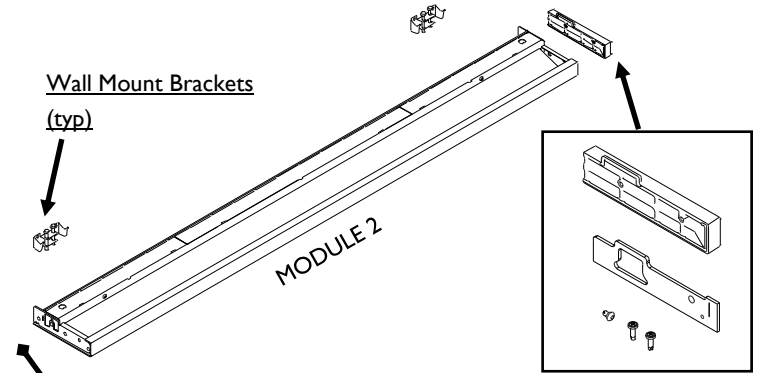

FloatPlane Joint Kit(s)

- Foam gasket
- #10-24 x 9/16" bolts (x2)
- #10-24 nuts (x2)
- Plastic rivet

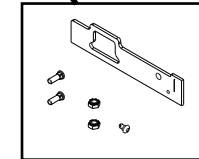

Module Lengths

FloatPlane wall mount fixtures come in 4ft, 6ft and 8ft modules. Overall module lengths are shown below. Add 9/16" for each EDGE endcap or 1" for each CURVE endcap.

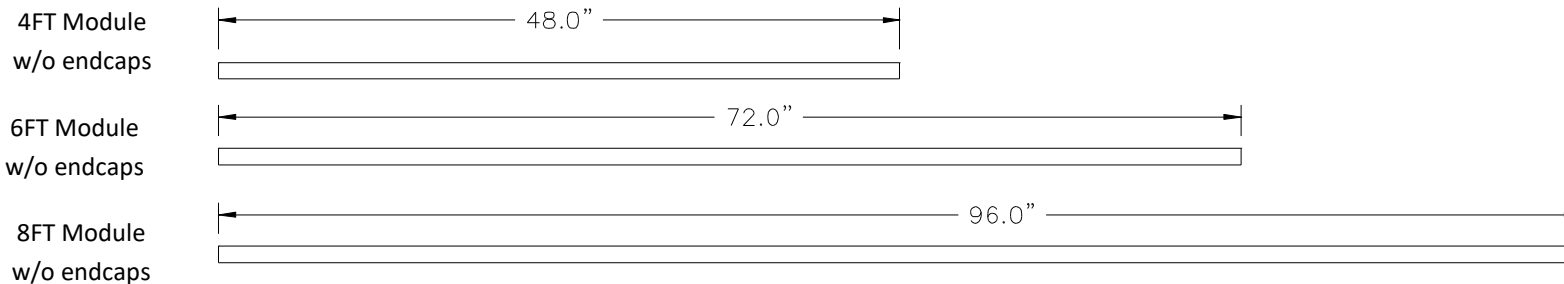

Tools Required:

- Medium Flat blade Screwdriver
- Medium Phillips Screwdriver
- 3/8" Nut driver
- 5/16" Nut Driver

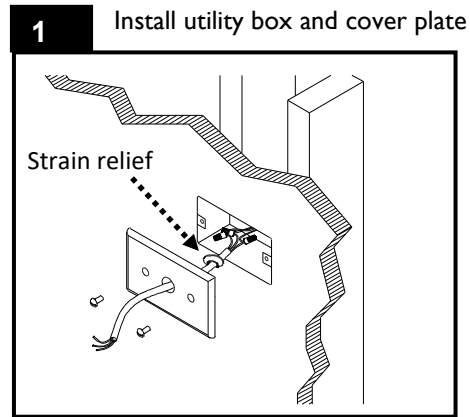

Determine power feed location and install 2"x4" utility box (supplied by others) parallel with fixture. Complete electrical connections at box with supplied power cord. Crimp supplied strain relief onto power cord insulation (recommend Heyco Tool PN0019(R12)). Attach cover using supplied painted hardware.

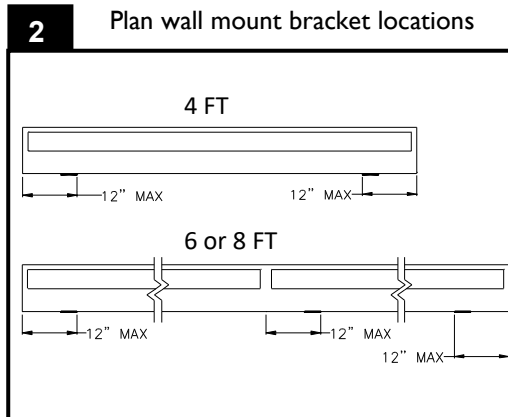

Determine wall mount bracket locations based on the allowable distance from fixture ends to brackets, and also factoring in site conditions (location of structural members).

Each 4FT fixture requires two brackets, and each 6 or 8 FT fixture require 3 brackets.

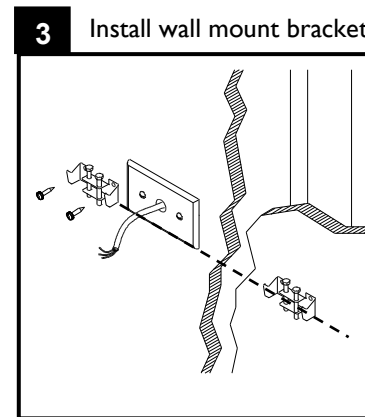

Install mount brackets to wall structure using appropriate fasteners (BY OTHERS). Note bottom of installed fixture will sit approx. 3/8" below bottom edge of bracket.

Bottom edge of wall bracket to be located flush with bottom edge of cover plate.

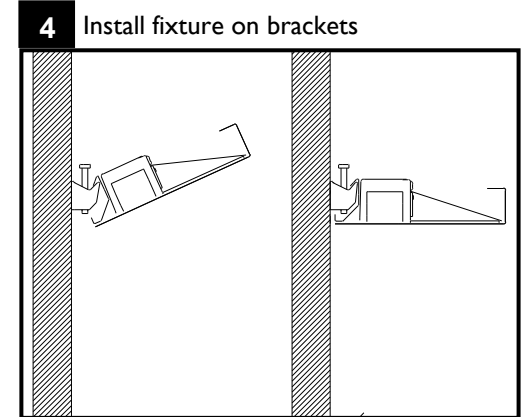

POWER LOCATIONS: Prior to engaging fixture on mounting brackets, feed installed power cord through one of the power access holes at the back of fixture.

With 2 people, raise fixture into position and engage it on hooks located on tops of brackets. Then let the fixture rotate down into position.

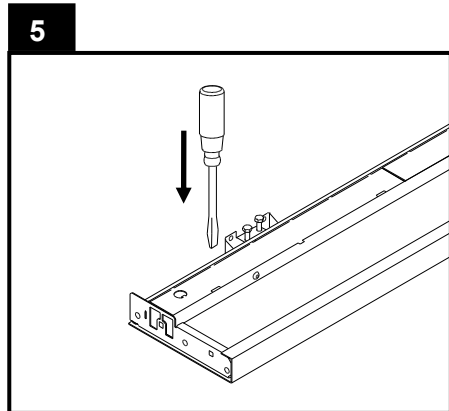

At power feed location on fixture. Insert a medium size flat blade screwdriver into slots on access panel.

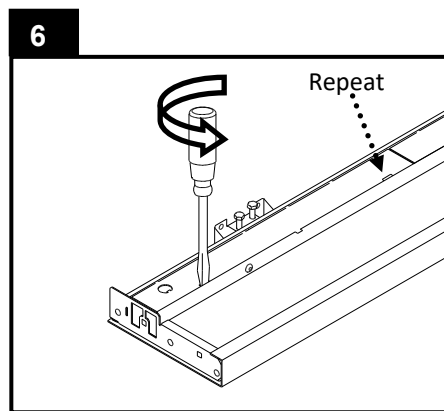

Twist the screwdriver and the tab on the access panel will POP UP. Repeat on the other tab on the access panel. Open the wire access panel.

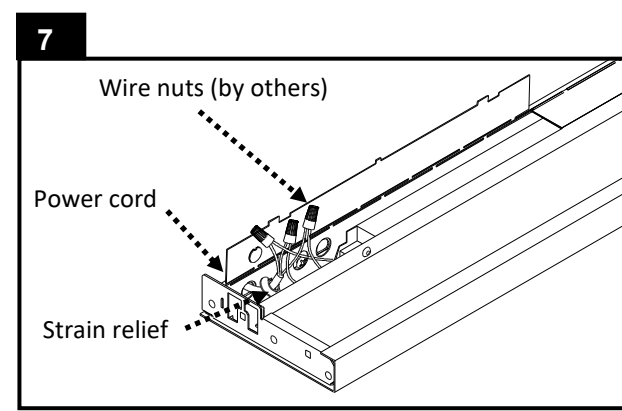

Crimp supplied strain relief onto power cord insulation (recommend Heyco Tool PN0019(R12)). Complete necessary electrical connections (by others) in compliance with local codes. Push the wires and connectors back down into the wire compartment when complete.

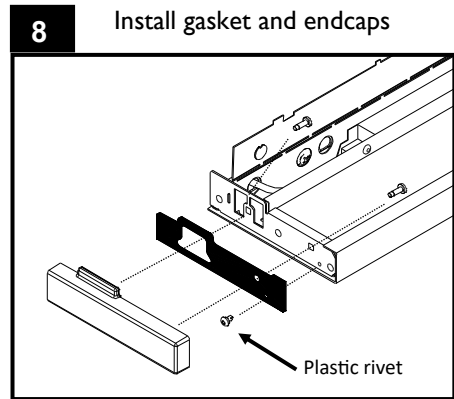

Insert the foam gasket onto the fixture end. Using the supplied plastic rivet, fasten the gasket in place so it doesn't move during endcap installation. Install LEFT or RIGHT endcap using supplied screws. Align the fixture housing to endcap for best aesthetic before final tightening.

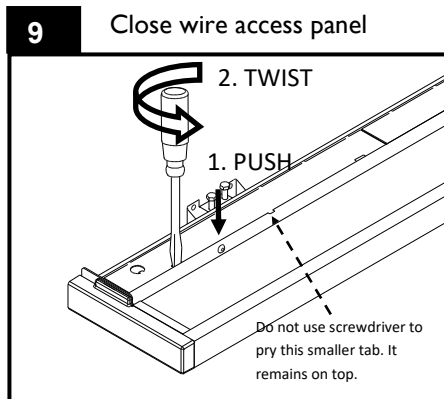

Ensure the electrical connectors are tucked inside the wire cavity. Push down on the lid while simultaneously twisting the flat blade screwdriver, the panel tab will lock into place. Repeat at the other screwdriver slot location.

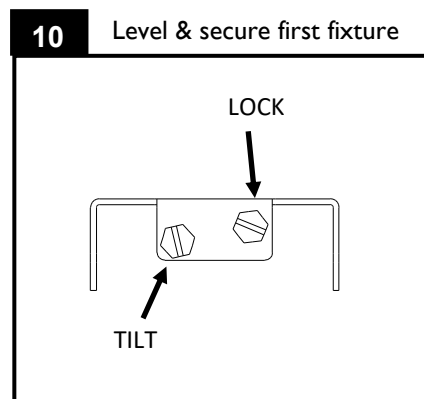

LEVEL: Using 5-16" nut driver, level fixture by adjusting the Tilt screw.

LOCK: Lock the fixture to wall bracket assemblies by tightening the Lock screw.

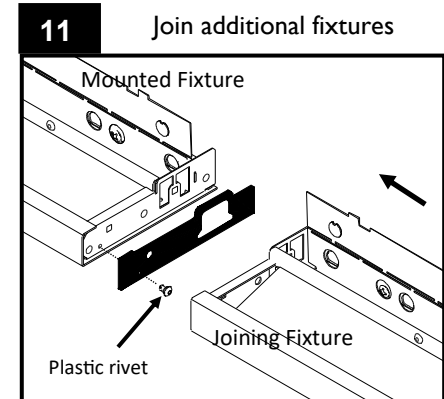

Insert the foam gasket onto the mounted fixture end. Using the supplied plastic rivet, fasten the gasket in place so it doesn't move during fixture joining.

Note the joining fixture requires its own mount brackets (2pcs if a 4FT, 3pcs if 6/8 FT)

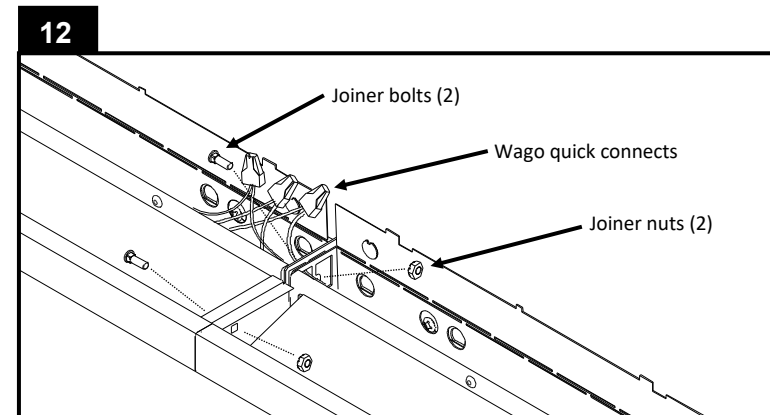

Ensure both fixtures are horizontal and mounted at the same height. Snug joining nuts using 3/8" nut driver, align the fixture housings for best aesthetic before final tightening. Complete necessary electrical connections in compliance with local codes. Close all wire access panels (step 9) when complete.

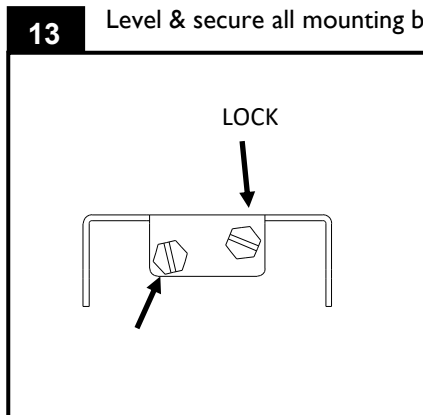

LEVEL: Using 5-16" nut driver, level fixture by adjusting the Tilt screw.

LOCK: Lock the fixture to wall bracket assemblies by tightening the Lock screw.

! ATTENTION: Install in accordance with national and local building and electrical codes.

ADDITIONAL INFORMATION

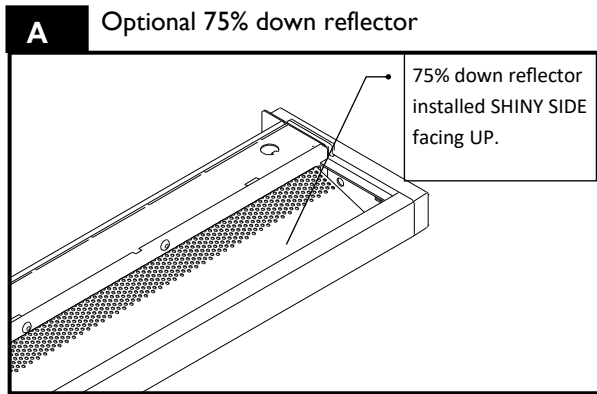

FloatPlane Fixtures available with a factory installed, perforated 75% down reflector. For best optical performance, reflector must be installed as shown, SHINY SIDE facing UP. Note down reflector is installed on top of clear acrylic upper diffuser.

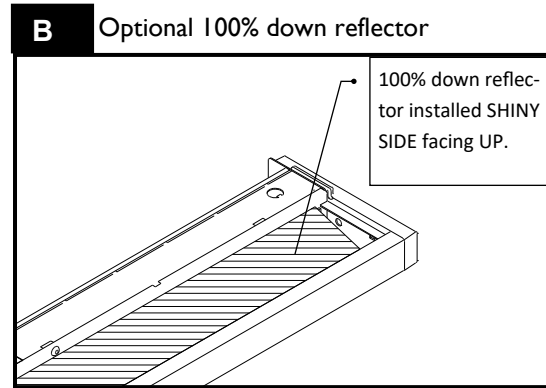

FloatPlane Fixtures available with a factory installed, solid 100% down reflector (shown as hatched lines). For best optical performance, reflector must be installed SHINY SIDE facing UP. Note down reflector is installed on top of clear acrylic upper diffuser.

C Removing & re-installing the upper diffuser

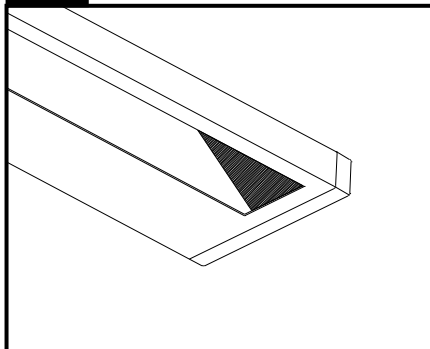

If the fixture is mis-handled during installation, a shadow may appear in the luminous window. This is caused by the upper diffuser being pushed below the LED.

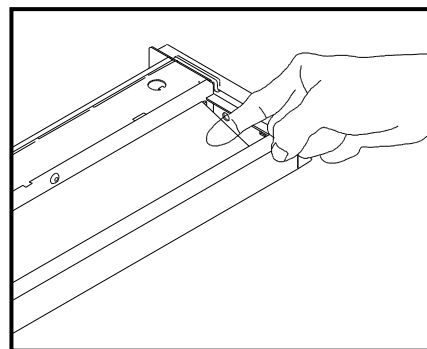

Insert finger underneath the upper diffuser and gently pry the panel free along the length.

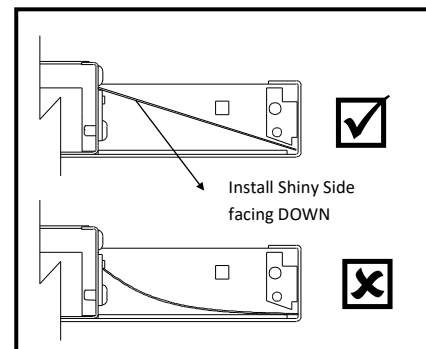

Re-install the upper diffuser (SHINY SIDE facing DOWN). If applicable, re-install optional 75 or 100% downlight reflectors on top of diffuser in correct orientation.