

# CHLORIDE

by  Signify

## Exit/Emergency

Steel-Lite series

Class I & II Division 2  
Emergency unit



Project: \_\_\_\_\_  
Location: \_\_\_\_\_  
Cat.No: \_\_\_\_\_  
Type: \_\_\_\_\_  
Lamps: \_\_\_\_\_ Qty: \_\_\_\_\_  
Notes: \_\_\_\_\_

### Example: SC50ZA2ICT

<u>Series</u>		<u>Lamp Heads</u>		<u>Lamp Head Qty</u>	<u>IC</u> <u>Model Designator</u>	<u>Options<sup>1</sup></u>
6 V, Lead Calcium SC25 – 25 W SC50 – 50 W	12 V, Lead Calcium STC25 – 25 W STC50 – 50 W STC100 – 100 W STC125 – 125 W	6 VDC Tungsten ZA – 8 W ZB – 18 W ZC – 25 W	12 VDC Tungsten ZE – 12 W ZF – 18 W ZG – 25 W	<b>Blank</b> – No Lamp Heads <b>1</b> – One Lamp Head <b>2</b> – Two Lamp Heads <b>3</b> – Three Lamp Heads	<b>IC</b> – Intelli-Charge Diagnostics	<b>A</b> – Ammeter <b>EX</b> – Special Input Transformer (specify voltage & frequency) <b>T</b> – Self-Testing Diagnostics <b>TA</b> – Audible Self-Testing Diagnostics <b>TD</b> – Time Delay (15 minutes) <b>V</b> – Voltmeter
6 V, Nickel Cadmium SN25 – 25 W SN50 – 50 W SN75 – 75 W	12 V, Nickel Cadmium STN25 – 25 W STN50 – 50 W STN75 – 75 W STN100 – 100 W STN125 – 125 W STN150 – 150 W	6 VDC Halogen ZI – 8 W ZJ – 12 W	12 VDC Halogen ZK – 8 W ZL – 12 W			

**Accessories<sup>2</sup> (Order Separately)**  
ICIR – Intelli-Charge Infra-Red Remote  
WG – Wire Guard

### Footnotes

- <sup>1</sup> Some option combinations may impact UL listing. Consult factory for specifications.  
<sup>2</sup> Consult Signify to confirm whether specific accessories are BAA-compliant.

### codes and standards

- UL 924 and 844 listed
- Temperature Rating (T-Rating) 160° (T3C)
- Class I, Zone 2 T-Rating 200° (T3)
- NFPA 101, NEC, IBC, BOCA, and OSHA illumination standard
- The Steel-Lite Series is UL listed for Class I, Division 2, Groups A, B, C & D; Class I, Zone 2, Groups IIA, IIB (+ H2) & IIC; and Class II, Division 2, Groups F & G.

### construction

- Constructed of impact-resistant, fiberglass-reinforced polyester gray housing and includes stainless steel hardware.
- View-through window allows easy monitoring of the optional voltmeter and ammeter.

### installation

- Wall mounted unit.

### electronics

- 120/277 VAC dual voltage input with surge protection is standard on all models.
- Self-powered models feature the Intelli-Charge circuit where the charging system is microprocessor driven with software embedded diagnostic routine and temperature compensation.
- Self-powered models include brownout detection, AC lockout, low voltage disconnect, AC power indicator, charge status indicator, audible user-interface controls, visual LED system fault indicator, and tactile push-to-test switch.
- Additional equipment safety features include reverse battery polarity detection and protection, and reverse utility power detection and protection.
- All self-powered models include an on-board IR receiver for use with the optional hand-held remote (ICIR).
- (optional self-testing electronics) The diagnostic/charging platform with optional self-testing mode automatically runs a one minute self-test once a month and a 30 minute test on the sixth and twelfth month in accordance with NFPA 101.
- A one minute or 90 minute test may be initiated via the push to test switch on the unit or by activating the appropriate test command on the optional IR test device.

# SC/SN/ST Steel-Lite series Class I & II, Division 2 emergency unit

25-150W

- Power Consumption  
6 VDC 25 & 50 W Lead Calcium: (120 VAC) 0.18 A, (277 VAC) 0.08 A.  
12 VDC 25, 50, 100 & 125 W Lead Calcium: (120 VAC) 0.40 A, (277 VAC) 0.18 A.  
6 & 12 VDC 25 W NiCad: (120 VAC) 0.088 A, (277 VAC) 0.042 A.  
6 VDC 50 & 75 W NiCad, 12 VDC 50 W NiCad: (120 VAC) 0.19 A, (277 VAC) 0.084 A.  
12 VDC 75 & 100 W NiCad: (120 VAC) 0.29 A, (277 VAC) 0.14 A.  
12 VDC 125 & 150 W NiCad: (120 VAC) 0.39 A, (277 VAC) 0.18 A.

## lamps

- Illumination is accomplished with up to three Class I, Div. 2 rated polycarbonate sealed beam Par 36 tungsten or halogen lamp heads mounted on the top of the unit for optimum path of egress illumination.

## battery

- Maintenance free sealed lead calcium with an operating range of 65°F (19°C) to 85°F (30°C).
- Maintenance free nickel cadmium battery with operating temperature range 65°F (19°C) to 85°F (30°C).
- Provides a minimum of 90 minutes of emergency power.

## warranty

- Five full years on electronics and unit (excluding lamps).

## options

- **A** – The ammeter option includes an analog meter electrically connected to the charging circuit for visual reference and indication of the current level being delivered to the battery.
- **EX** – The special input transformer option allows for input voltage and frequencies beyond the standard 120/277 VAC, 60 Hz input.
- **T** – The self-testing option enables a periodic self-test of the equipment where a test routine is established to perform a one minute once a month with a 30 minute test performed on the sixth and twelfth month in accordance with NFPA 101. Equipment readiness faults are indicated with a visual LED display.
- **TA** – The audible self-testing option enables a periodic self-test of the equipment where a test routine is established to perform a one-minute test once a month with a 30 minute test performed on the sixth and twelfth month in accordance with NFPA 101. Equipment readiness faults are indicated with a visual LED display and an audible alarm.
- **TD** – The time delay circuit causes the emergency lighting equipment to remain under battery power for a period of 15 minutes after the utility power has been restored.
- **V** – The voltmeter option includes an analog meter electrically connected between the battery and lamp load for visual reference and indication of the battery terminal voltage when the equipment is operating in the emergency mode.

## dimensions

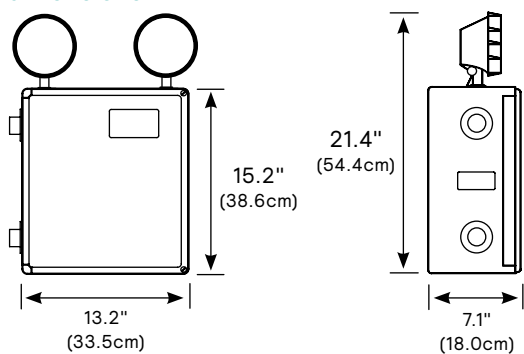

# SC/SN/ST Steel-Lite series Class I & II, Division 2 emergency unit

25-150W

## performance

Meets Life Safety Code illumination standard; average of 1.0 FC, no point less than 0.1 FC, max to min ratio of 40:1. Assumes open space with no obstructions, mounting height: 7.5' and reflectances: 80/50/20. Analysis based on independently tested photometrics.

Wall Mounted 7.5' AFF, 12 V 12 W Halogen Lamp Heads Represented  
1 FC Average

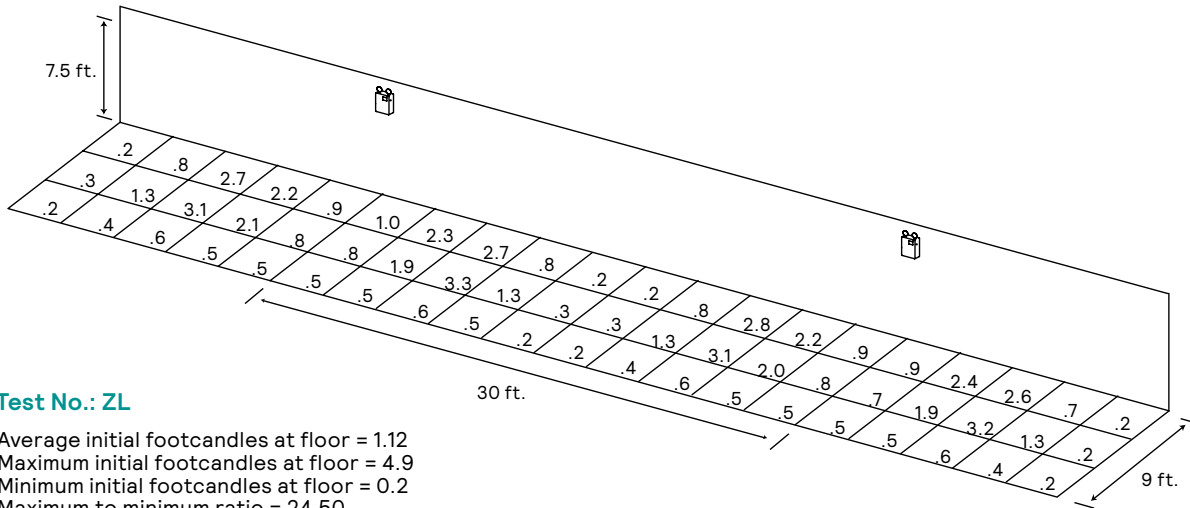

## Test No.: ZL

Average initial footcandles at floor = 1.12  
Maximum initial footcandles at floor = 4.9  
Minimum initial footcandles at floor = 0.2  
Maximum to minimum ratio = 24.50

## Buy American Act of 1933 (BAA):

This product is manufactured in one of our US factories and, as of the date of this document, this product was considered a commercially available off-the-shelf (COTS) item meeting the requirements of the BAA. This BAA designation hereunder does not address (i) the applicability of, or availability of a waiver under, the Trade Agreements Act, or (ii) the "Buy America" domestic content requirements imposed on states, localities, and other non-federal entities as a condition of receiving funds administered by the Department of Transportation or other federal agencies. Prior to ordering, please visit [www.signify.com/baa](http://www.signify.com/baa) to view a current list of BAA-compliant products to confirm this product's current compliance.



© 2021 Signify Holding. All rights reserved. The information provided herein is subject to change, without notice. Signify does not give any representation or warranty as to the accuracy or completeness of the information included herein and shall not be liable for any action in reliance thereon. The information presented in this document is not intended as any commercial offer and does not form part of any quotation or contract, unless otherwise agreed by Signify.

Signify North America Corporation  
200 Franklin Square Drive,  
Somerset, NJ 08873  
Telephone 855-486-2216

Signify Canada Ltd.  
281 Hillmount Road,  
Markham, ON, Canada L6C 2S3  
Telephone 800-668-9008

All trademarks are owned by Signify Holding or their respective owners.