

READ AND UNDERSTAND ALL TRACK, CONNECTOR, FEED-IN-KITS, AND ACCESSORY INSTRUCTION SHEETS BEFORE INSTALLING ANY TRACK ITEM.

This fixture is intended for installation in accordance with the National Electrical Code and local or Federal code specifications. To assure full compliance with codes and regulations, check with your local electrical inspector before installation. To prevent electric shock, turn off electricity at fuse box before proceeding.

Retain these instructions for maintenance reference.

**Installation Instructions for Swivel Stem Mounting Kits
for use with Lytespan and ProSpec™ Track Systems Only.**

Caution:

- Turn off power at fuse box before installing track.
- Instructions for grounding must be followed. Failure to do so may result in a hazardous condition.
- Use only #12 ga. solid copper wire in connectors to maintain proper track rating.
- Do not supply Advent Track from two separate 120V branch circuits as this could overload the neutral track conductor leading to an electrical safety hazard.
- Observe polarity, white (neutral) wire must be connected to terminal marked "NEUT". Failure to observe Polarity may result in an electrical hazard.

Swivel Stem mounting kits (0-90 deg., 48" long), for use in sloped ceilings, may be attached to the track at any point and may be spaced up to 4' apart. They are also used to feed power to the track: use the stem closest to the track feed-in point. The unthreaded end of the stem may be field cut using a hacksaw or similar cutting device. The Stem Extension Kit (48") is used to lengthen a stem (this stem cannot be field cut).

A. FASTEN NON-POWER FEED STEMS TO CEILING

1. Mark centerline for track through center of outlet box.
2. Thread Mounting Screws into Stem Mounting Plates (Fig. C). Remove green screw and washer from Non-Power Feed Stems. Fasten Stem Mounting Plates to ceiling, either to building structure or with permanent fasteners capable of supporting at least 50 lbs. each. Space Stems no more than 4' apart. (See Fig. A.)
3. Attach all Stems which do not carry Supply Leads as follows: Slide Upper Swivel Housing over Swivel Casting Assembly and attach to Neck Wireway. (See Fig. C).

Drive Longer Set Screw into Upper Swivel Housing and through hole in front of casting until you engage the hole in Neck Wireway. Place Canopy over Swivel Casting Assembly and Mounting Screws. (See Fig. C).

Secure with Cap Screws until Canopy rests tightly against ceiling. Slide Stem into Swivel Casting Assembly and drive Set Screw through hole in the side of casting. Slide Lower Casting Assembly.

Drive Set Screw into Lower Swivel Housing and through the hole in the front of casting until Stem is held tight. Assembly Track Clamps using Flat Head Screws. Screw Track Clamps onto bottom of Stem. (See Figs B and E.)

B. Fasten Power Feed Stem to Outlet Box

1. Outlet Box must be capable of supporting a maximum weight of 50 pounds. Power Feed Stem must be adjacent to track feed-in point. **Note:** Wires cannot pass beneath two stems.
2. Thread Mounting Screws into Stem Mounting Plate (Fig. Cc).
3. Pass Supply Leads (#12 AWG solid TW wires supplied by others) through Swivel Casting Assembly. Leave at least 6" of Supply Lead

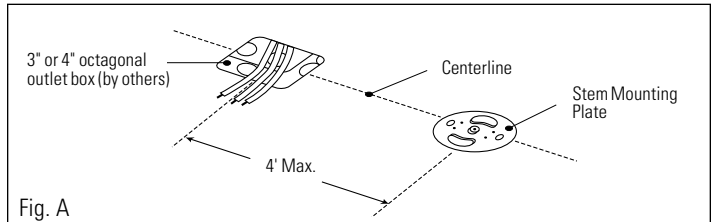

Fig. A

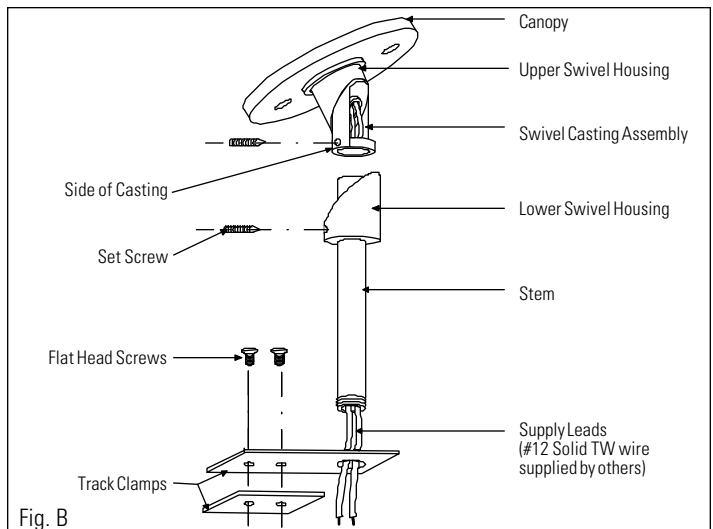

Fig. B

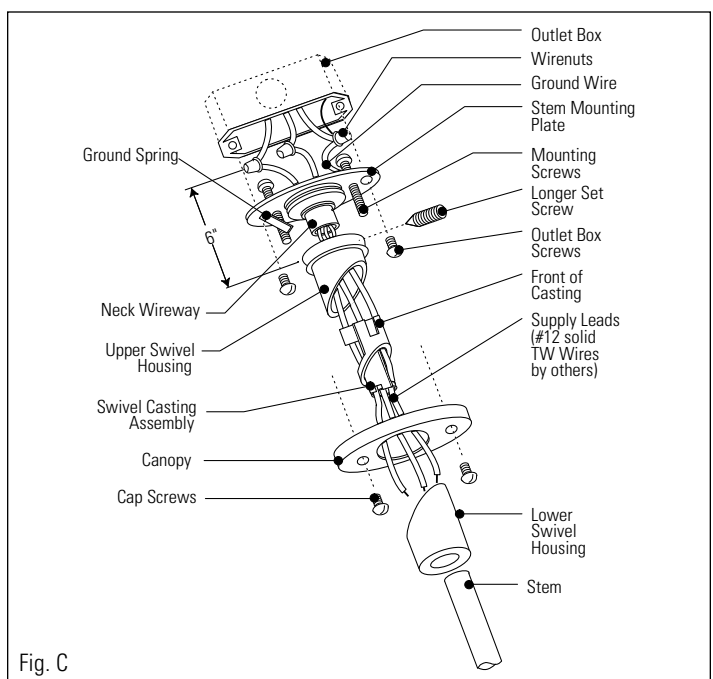

Fig. C

**Installation Instructions for Stem Mounting Kit
for use with Lytespan and ProSpec™ Track Systems Only.**

for splicing, and enough wire to run horizontally along upper section of track to power feed-in point, plus additional wire for attaching to power feed connections. Slide Upper Swivel Housing over Supply Leads and Swivel Casting Assembly. Feed Supply Leads through Neck Wireway. Attach Upper Swivel Housing and Swivel Casting Assembly to Neck Wireway, by driving Longer Set Screw into Upper Swivel Housing and through the hole in the front of the casting until you engage the hole in the Neck Wireway. (Fig. C).

4. Splice Supply Leads to branch circuit wiring in outlet box. White to white, black to black (red to red in Advent). Attach 12 AWG Branch Circuit ground wire between washer and green screw on Mounting Plate. (Fig. C.)
5. Fasten Stem Mounting Plate to Outlet Box with Outlet Box Screws. Place Canopy over assembly and Mounting Screws. Secure with Cap Screws until Canopy rest tight against ceiling.
6. Pass supply leads through unthreaded end of stem. Slide stem into Swivel casting Assembly and drive Set Screw through hole on the side of casting until tight. Slide Lower Swivel Housing over Stem and onto Swivel Casting Assembly. Drive Set Screw into Lower Swivel Housing and through hole in the front of casting until Stem is held tight.
7. Drive Flat Head Screws into Track Clamps. Screw Track Clamps onto bottom of Stem. (See Figs. C and E.)

C. Mounting Track Units onto Stems

1. Loosen Screws on Track Clamps. For feed stem, the Track Clamp must be positioned as shown in Fig.D-1. Place Track Ribs (Fig. D-3) between Track lamps and slide track into position. Make sure Bead (Fig. D-3) of Track Units are in-line with one another when using more than one Track Unit..
2. Run Supply Leads along top of track toward Live End. Loosed screw in Live End and remove from track.
3. Cut Wireway Cover to distance from Track Clamp to end of Track Unit. Slide Wireway Cover into track over Supply Leads. (Fig. D-1, D3).
4. Remove Bottom Cover from Live End.
5. Break off Barrier in Live End by bending it back and forth. (Fig. D-2)
6. Pass Supply Leads through Barrier opening in Live End. Insert Live End into Track Unit and tighten Screw. For ProSpec feed track place wire cover into track before attaching the stems to the track unit.
7. Connect Supply Leads to screw terminals as shown in Instruction Sheet IS:6020, IS:6121, for Advent, or IS:26000, IS:26046, IS:26050 for ProSpec. Ground terminal in Live End is not used when feeding power from a Stem.
8. Fasten Bottom Cover to Live End. Tighten Screws on all Track Clamps.

D. Instructions for Stem Extension Kits

1. Screw Coupling to threaded end of Stem supplied with Stem Mounting Kit (Fig. E).
2. Screw Stem supplied with Stem Extension Kit to Coupling (Fig. E).
3. Complete installation of Stem Mounted Lytespan Track following steps in B.

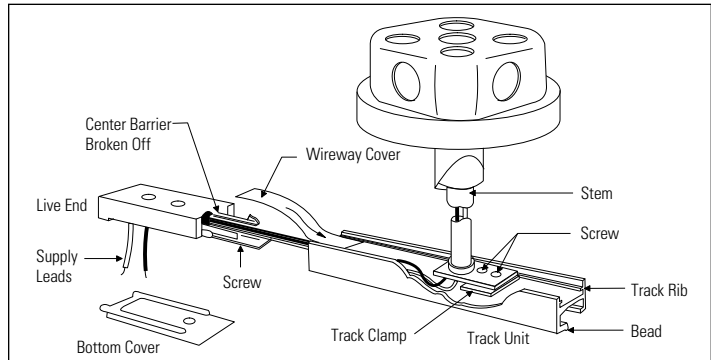
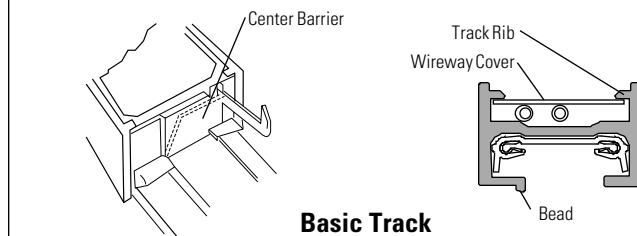
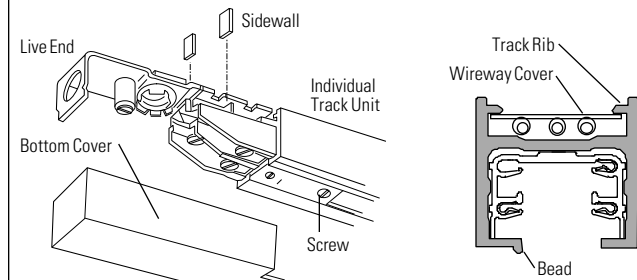

Fig.D-1



Basic Track



Advent Track

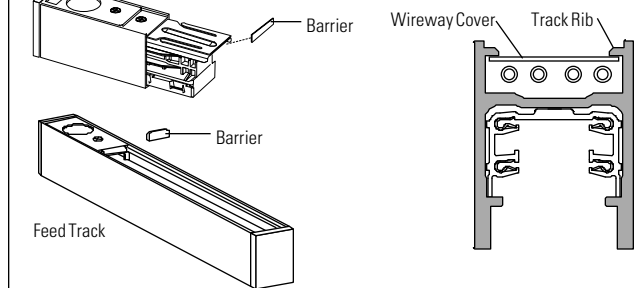

ProSpec Track

Fig. D-2

Fig. D-3

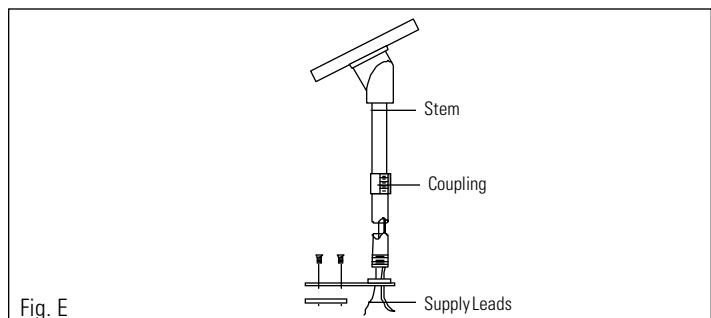

Fig. E