

CHLORIDE

by 

Exit/Emergency

B200 series

Industrial emergency unit, 12V



Project:	
Location:	
Cat.No:	
Type:	
Lamps:	Qty:
Notes:	

Chloride B200 series is a heavy duty industrial 12V emergency unit ideal for use in institutional and industrial locations where a high capacity unit with the capability of operating multiple remote fixtures is desired. B200 Series meets the Buy American requirements.

Ordering guide

Example: B2002H7FBIC

Model	No. of Heads	Lamp Head Type	Model Designator BC	Options	Accessories (ordered separately)
B200					
B200 12V 174W Unit	2 Two Heads Blank No Heads	H7FB 12V MR16 7W LED, black finish (equivalent to 35W incandescent lamp) M7FB 12V MR16 7W LED, black finish (equivalent to 35W incandescent lamp) LP15 12V LED 15W LED, PAR36, NEMA gray finish (equivalent to 75W incandescent lamp) LP20 12V LED 20W LED, PAR36, NEMA gray finish (equivalent to 100W incandescent lamp)	IC Self-Diagnostic ICT Self-Diagnostics with Self-Testing ICTA Self-Diagnostics with Audible Self-Testing	EX Special Input Transformer (specify voltage & frequency) ¹ TD Time Delay (15 minutes)	WG Wire Guard MBBG Mounting Bracket ICIR Infra-Red Remote Tester

1. Some option combinations may impact UL Listing.

codes & Standards

- ETL listed to UL 924 Standard.
- NFPA 101, NEC, BOCA, OSHA, and IBC illumination standards
- B200 with six H7FB or M7FB lamp heads (4 are remote heads) meets NRC requirements for an eight-hour run time.

application

- Institutional and industrial locations with normal ambient temperatures where a high capacity emergency unit with capability of operating multiple remote fixtures is desired
- B200 meets the Buy American requirements

construction

- 18 gauge steel wall mounted housing and door with hammer tone gray epoxy powder coat finish.

warranty

- 3 year warranty on electronics.
- LEC-361: 5 years full warranty, 10 years pro-rata

electrical

- 120/277 dual voltage input with surge protection is standard on all models.
- Self-powered models feature the Intelli-Charge circuit where the charging system us microprocessor driven with software embedded diagnostic routine and temperature compensation.
- Self-powered models include brownout protection, AC lockout, low voltage disconnect, AC power indicator, charge status indicator, audible user-interface controls, visual LED system fault indicator and tactile push-to-test switch.

- Additional equipment safety features include reverse battery polarity detection and protection, and reverse utility power detection and protection.
- All self-powered models include an on board IR receiver for use with the optional hand held remote (ICIR).
- Optional self-testing electronics provide a diagnostic/charging platform with optional self-testing mode, which automatically runs a one minute self-test once a month and a 30 minute test on the sixth and twelfth month in accordance with NFPA 101.
- A one minute or 90 minute test may be initiated via the push to test switch on the unit or by activating the appropriate test command on the optional IR test device.

B200 Industrial emergency unit

12V

batteries

- Extra long-life, heavy industrial grade, LEC-361 sealed lead calcium battery
- 6V, 36 ampere hour (AH) minimum capacity
- Cell design protects against deep discharge and requires no addition of water
- Low specific gravity 1.25 (±.10) reduces corrosion rates and lowers electrode sulphation.
- Expected life up to 20 years.
- Increases or decreases in temperature will affect battery performance and/or capacity. Optimum battery performance realized at 77°F (25°C).

power consumption

- B200 @120VAC, .532A
- B200 @277VAC, .245A

options

- TD - Time Delay circuit causes the emergency lighting equipment to remain under battery power for a period of 15 minutes after the utility power has been restored.
- EX - The special input transformer option allows for input voltage and frequencies beyond the standard 120/277 VAC 60Hz input.
- IC - All models feature the Intelli-Charge circuit where the charging system is microprocessor driven with software embedded diagnostic routine and temperature compensation.
- ICT - This self-testing option enables a periodic self-test of the equipment where a test routine is established to perform a one minute test once a month with a 30 minute test performed on the 6th and 12th month in accordance with NFPA 101 Equipment readiness are indicated with a visual LED display.

- ICTA - The audible self-testing option enables a periodic self-test of the equipment where a test routine is established to perform a one minute test once a month with a 30 minute test performed on the 6th and 12th month in accordance with NFPA 101 Equipment readiness are indicated with a visual LED display and an audible alarm.

lamp selection

- The B200 H Head features a dual-axis swivel mount and is constructed of high-impact polycarbonate, and is offered in black to complement the unit's gray housing. It utilizes a 12 volt MR16, 7 watt LED lamp.
- The B200 M head is constructed of a deep drawn powder-painted black steel lamp head utilizing a 12 volt MR16, 7 watt LED lamp for maximum performance.
- The B200 LP15 and LP20 lamp heads are constructed of a NEMA rated polycarbonate gray housing. The PAR 36 LED lamp head is available with either the 12V LP15 (15 watts) or LP20 (20 watts) LED lamp for optimum path of egress illumination.

Model	AC Input		DC Voltage	Wattage to 87.5 of Rated Voltage*			
	Voltage	Amps		1.5 hrs.	2 hrs.	4 hrs.	8 hrs.
B200	120/277	.14/.06 Amps	12	174	131	84	48

*Per NFC specifications.

12V/174W industrial emergency unit

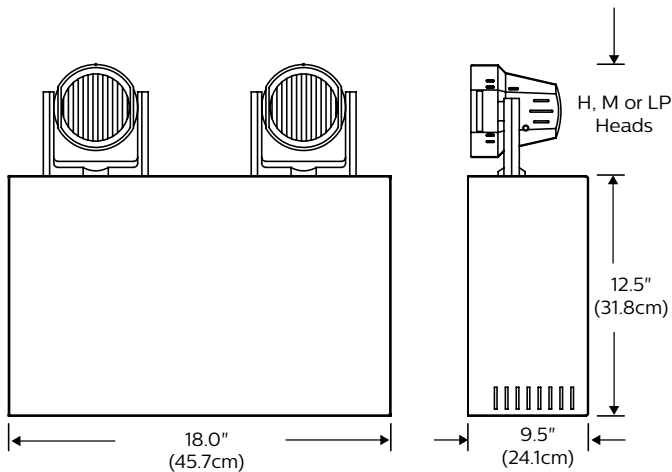

H-Head, LED

H7FB - 12V/7W/LED
3.5" H X 4.6" W



M-Head, LED

M7FB - 12V/7W/LED
5" H X 3.53" W

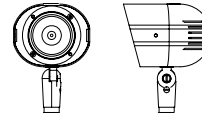

Heavy Duty Industrial, LED, PAR36

LP15 - 12V/15W/LED LP20 - 12V/20W/LED
6.25" H X 5.1" W 6.25" H X 5.1" W

