

**INSTRUCTIONS FOR LYESPAN ATTACHMENT FITTING****A. CORD PENDANT MOUNTING****(supports up to 10 lbs.)**

1. Unscrew LEVER. Remove PLUG ASSEMBLY, HOUSING INSERT from attachment HOUSING. See Fig. 1.
2. See "WIRING PROCEDURE" below.

**B. STEM MOUNTING USING 1/2" O.D. TUBING****(supports up to 25 lbs.)**

1. Unscrew LEVER, STRAIN RELIEF CAP and KNURLED RING. Remove PLUG ASSEMBLY, HOUSING INSERT from attachment HOUSING.
2. Use STEM TUBING with 1/4-18 pipe thread 3/4" long (not supplied). Screw KNURLED RING onto STEM TUBING. See Fig. 1A.
3. Insert STEM TUBING into attachment HOUSING and screw on LOCKNUT until secure. Tighten KNURLED RING to lock in place.
4. See "WIRING PROCEDURE" below.

**C. CHAIN MOUNTING****(supports up to 25 lbs.)**

1. Unscrew LEVER and STRAIN RELIEF CAP. Remove PLUG ASSEMBLY, HOUSING INSERT from attachment HOUSING.
2. Replace STRAIN RELIEF CAP with 1/4-18 CHAIN LOOP (not supplied). See Fig. 1B.
3. See "WIRING PROCEDURE" below.

**D. WIRING PROCEDURE**

1. Remove 2" of outer insulation from FIXTURE CORD (when required) and strip conductor ends 3/4". See Fig. 1.
2. Insert FIXTURE CORD through attachment housing. Fasten BLACK WIRE to LONGER (BRASS) CONTACT and WHITE WIRE to SHORTER (SILVERED) contact. For 3 conductor cord, splice GROUND LEADS with wire connector. (If the GROUND LEAD from the attachment HOUSING is not used, leave wire connector on.) See Fig. 1.

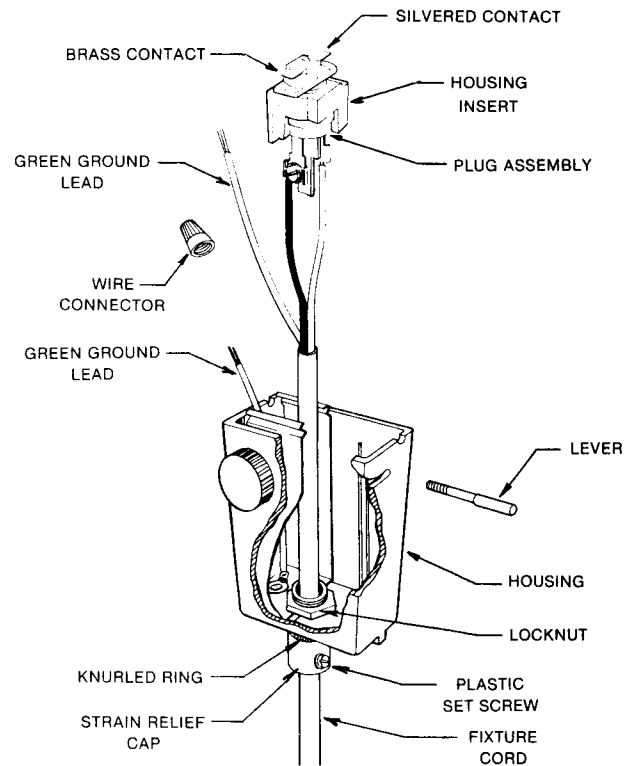

FIG. 1

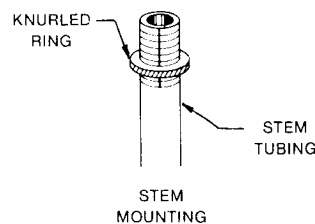

FIG. 1A

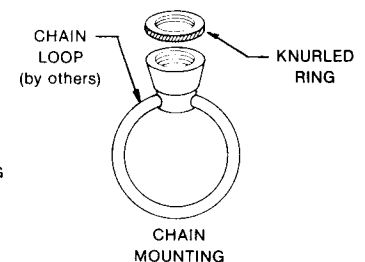

FIG. 1B

**CAUTION: OBSERVE POLARITY WHEN FASTENING WIRES. BEND WIRES AROUND SCREW IN CLOCKWISE DIRECTION.**

3. Pull FIXTURE CORD back through attachment HOUSING and push HOUSING INSERT and PLUG ASSEMBLY into HOUSING (silvered contact in PLUG ASSEMBLY facing grooved side of attachment HOUSING). Push ground leads into area between SPRING section. Fig. 2.
4. Allow fixture cord to extend into attachment HOUSING by 1/8" and tighten PLASTIC SET SCREW. Fig. 2.

**CAUTION: TIGHTEN ENOUGH TO SUPPORT ASSEMBLY.**

5. Screw LEVER into PLUG ASSEMBLY.

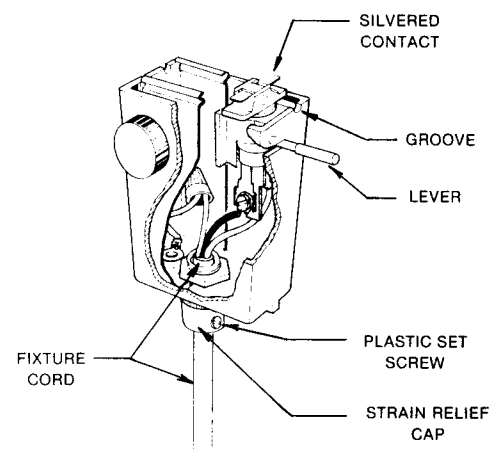

FIG. 2

## INSTRUCTIONS FOR ATTACHING LYTESPAN ATTACHMENT FITTING

1. Align BEAD on LYTESPAN TRACK and GROOVE in attachment FITTING before inserting into LYTESPAN TRACK. See Fig.1 (If BEAD is NOT aligned, a potential hazard may result.)
2. Unscrew the TURN KNOB partially and position LEVER as shown in Fig. 1.
3. To attach attachment FITTING: squeeze BUTTON and TURN KNOB, insert into LYTESPAN TRACK, and release. Tighten TURN KNOB. This holds attachment FITTING to LYTESPAN TRACK mechanically. Turn LEVER to make electrical connection. See Fig. 2.
4. To shift fixture location on the LYTESPAN TRACK loosen TURN KNOB slightly, release LEVER and slide to new position.
5. To remove fixture reverse the procedure in (3), push TURN KNOB in and allow attachment FITTING to disengage.
6. Fixture can be left on LYTESPAN TRACK when not in use by turning LEVER to disconnect electrically.

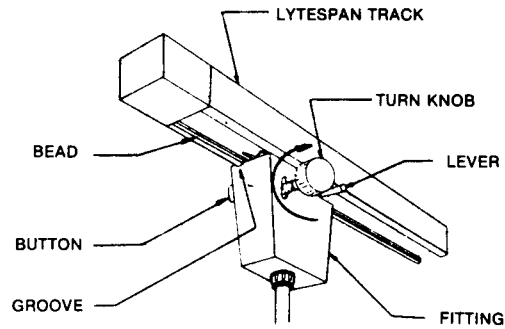

FIG. 1

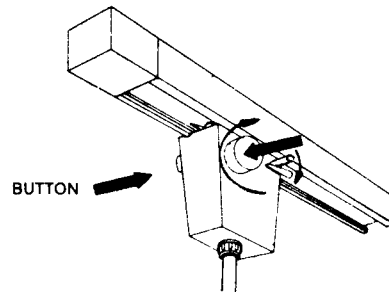

FIG. 2

## INSTRUCTIONS FOR CONVERTING LYTESPAN ATTACHMENT FITTING TO OPERATE ON (2 CIRCUIT) LYTESPAN TRACK.

**NOTE:** To insure proper operation of Lytespots on Two Circuit Lytespan Track, the BLACK SPACER (supplied) must be used at all times on the plug assembly.

The BLACK SPACER is not used when operating Lytespots on Single Circuit Track.

### LOWER CIRCUIT, FIG. 3:

Illustrates contacts in low position with spacer in place for lower circuit.

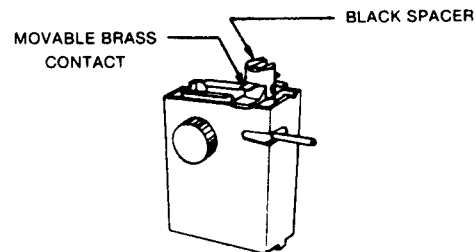

FIG. 3

### UPPER CIRCUIT, FIG. 4 and 5:

To convert attachment fitting for upper circuit, raise BRASS CONTACT to high position (as indicated by dotted line) by pulling CONTACT as high as stop permits and slipping on BLACK SPACER as shown in Fig. 4 and 5.

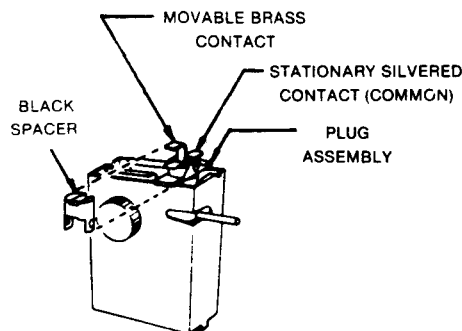

FIG. 4

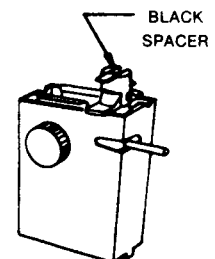

FIG. 5