



Lumece **MiniView LED** roadway luminaire is the perfect solution when projects require a luminaire that meets specifications without sacrificing performance, all while maximizing operations and maintenance savings. This roadway luminaire features a single IP66-rated LED module, designed to provide crisp, brilliant white light that surpasses existing HID luminaire performance. Optimized for applications such as local roads and residential streets, its overall size, weight, and tool-free feature ensure ease of installation. MiniView makes upgrading to reliable, long-lasting, low-maintenance LED lighting a simple cost-effective decision for cities, municipalities, and utilities.

Project: \_\_\_\_\_

Location: \_\_\_\_\_

Cat.No: \_\_\_\_\_

Type: \_\_\_\_\_

Lamps: \_\_\_\_\_ Qty: \_\_\_\_\_

Notes: \_\_\_\_\_

### Ordering guide

example: SVS-54W16LED4K-G2-LE2-UNV-DMG-PH8-RCD-GY3

Series	LED Module	Board Generation	Optical System	Ballast	Driver Options	Luminaire Options	Finish
<b>SVS</b> -	-	-	-	<b>UNV</b> -	-	-	<b>GY3</b>
<b>SVS</b> MiniView LED roadway luminaire	<b>3000K</b> <b>25W16LED3K</b> <b>35W16LED3K</b> <b>54W16LED3K</b>  <b>4000K</b> <b>25W16LED4K</b> <b>35W16LED4K</b> <b>54W16LED4K</b>	<b>G2</b>	<b>LE2</b> Type II (ASYM) <b>LE3</b> Type III (ASYM)	<b>UNV</b> 120-277VAC	<b>DMG<sup>1</sup></b> Dimmable driver 0-10V	<b>None</b> (leave blank) <b>API</b> Factory installed NEMA label, ANSI C136.15 compliant <b>HS</b> House side shield <b>PH8<sup>2</sup></b> Photoelectric cell <b>PHXL<sup>2</sup></b> Photoelectric cell, extended life <b>PH9<sup>2</sup></b> Shorting cap <b>RCD<sup>1,3</sup></b> Receptacle for twist-lock photocell or shorting cap, 5-pin (standard) <b>RCD7<sup>3</sup></b> Receptacle for twist-lock photocell or shorting cap, 7-pin (optional)	<b>GY3</b> Grey finish

1. Please note these integrated features come standard with MiniView luminaire.  
 2. Luminaire option RCD or RCD7 is required with these options.  
 3. Use of photoelectric cell or shorting cap is required to ensure proper illumination.

# SVS MiniView LED (small)

## Roadway

### LED Wattage and Lumen Values

Ordering Guide	Total LEDs	LED Current (mA)	Average System Watts <sup>1</sup> (W)	Type LE2			Type LE3		
				Delivered lumens <sup>2</sup>	Efficacy LPW	BUG Rating	Delivered lumens <sup>2</sup>	Efficacy LPW	BUG Rating
<b>3000K</b>									
SVS-25W16LED3K-G2	16	470	25	2,561	101.5	B1-U0-G1	2,553	101.2	B1-U0-G1
SVS-35W16LED3K-G2	16	700	36	3,477	95.6	B1-U0-G1	3,483	95.8	B1-U0-G1
SVS-54W16LED3K-G2	16	1050	55	4,776	87.3	B1-U0-G1	4,736	86.6	B1-U0-G1
<b>3000K-HS</b>									
SVS-25W16LED3K-G2-HS	16	470	25	1,977	78.3	B0-U0-G0	1,956	77.5	B0-U0-G0
SVS-35W16LED3K-G2-HS	16	700	36	2,684	73.8	B1-U0-G1	2,669	73.4	B1-U0-G1
SVS-54W16LED3K-G2-HS	16	1050	55	3,687	67.4	B1-U0-G1	3,628	66.3	B1-U0-G1
<b>4000K</b>									
SVS-25W16LED4K-G2	16	470	25	2,945	116.7	B1-U0-G1	2,936	116.4	B1-U0-G1
SVS-35W16LED4K-G2	16	700	36	3,998	110.0	B1-U0-G1	4,005	110.2	B1-U0-G1
SVS-54W16LED4K-G2	16	1050	55	5,492	100.4	B1-U0-G1	5,446	99.6	B1-U0-G1
<b>4000K-HS</b>									
SVS-25W16LED4K-G2-HS	16	470	25	2,273	90.1	B1-U0-G0	2,250	89.2	B1-U0-G1
SVS-35W16LED4K-G2-HS	16	700	36	3,086	84.9	B1-U0-G1	3,069	84.4	B1-U0-G1
SVS-54W16LED4K-G2-HS	16	1050	55	4,240	77.5	B1-U0-G1	4,173	76.3	B1-U0-G1

1. System input wattage may vary based on input voltage by up to +/- 10% and based on manufacturer forward voltage by up to +/- 8%.

2. Lumen values based on photometric tests performed in compliance with IESNA LM-79.

Note: Some data may be scaled based on tests of similar. But not identical luminaires.

### Predicted Lumen Depreciation Data

Predicted performance derived from LED manufacturer's data and engineering design estimates, based on IESNA LM-80 methodology.

Actual experience may vary due to field application conditions. L<sub>70</sub> is the predicted time when LED performance depreciates to 70% of initial lumen output. Calculated per IESNA TM21-11. Published L<sub>70</sub> hours limited to 6 times actual LED test hours

Ambient Temperature °C	Driver mA	Calculated L <sub>70</sub> Hours	L <sub>70</sub> per TM-21	Lumen Maintenance % at 60,000 hrs
Up to 40°C	up to 1050 mA	>100,000 hours	>60,000 hours	>96%

### Dimensions

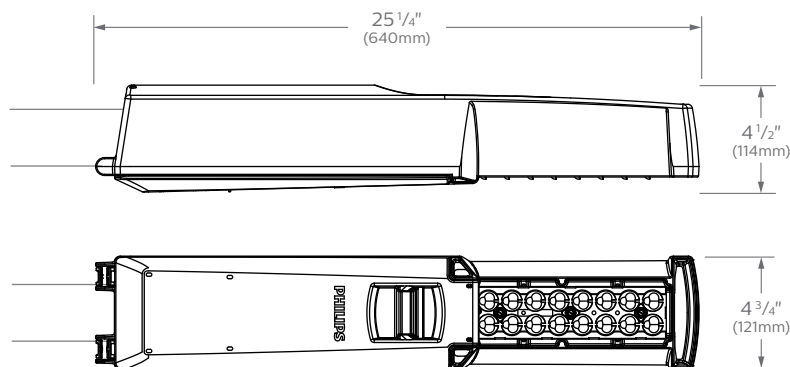

**EPA:** 0.85 sq. ft.

**Weight:** 25/35W: 7.5 lbs. (3.4 kg)  
54W: 8.1 lbs. (3.7 kg)

# SVS MiniView LED (small)

## Roadway

### Specifications

#### Housing

Made of low copper die cast A360 Aluminum alloy 0.100" (2.5mm) minimum thickness. Fits on a 1.66" (42mm) O.D. (1.25" NPS) or 2 3/8" (60mm) O.D. (2" NPS) by 5 1/4" (133mm) minimum long tenon. Comes with a zinc plated clamp fixed by 2 zinc plated hexagonal bolts 3/8-16 UNC for ease of installation. Provides an easy step adjustment of +/- 5° tilt in 2.5° increments. Includes integral bubble level standard (always included). A quick release, tool less entry, hinged, removable polymeric door opens downward to provide access to electronic components and to a terminal block. Door is secured to prevent accidental dropping or disengagement. A clearance of 8" (203mm) at the rear is required in order to open the door. Complete with a bird guard protecting against birds and similar intruders and an ANSI label to identify wattage and source (both included in box).

#### Light Engine

Composed of 4 main components: LED Module / Optical System / Heat Sink / Driver.

#### IP Rating

Electrical components are RoHS compliant, IP66 sealed light engine.

#### LED Board and Array

LEDs tested by ISO 17025-2005 accredited lab in accordance with IESNA LM-80 guidelines in compliance with EPA ENERGY STAR, extrapolations in accordance with IESNA TM-21. Metal core board ensures greater heat transfer and longer lifespan.

#### LED Module

Composed of 16 high-performance white LEDs. Color temperature as per ANSI bin 4000 Kelvin nominal (3985K +/- 275K or 3710K to 4260K) or Warm white, 3000 Kelvin nominal (3045K +/- 175K or 2870K to 3220K), CRI 70 Min. 75 Typical.

#### Optical System

Composed of high-performance optical grade polymer refractor lenses to achieve desired distribution optimized to get maximum spacing, target lumens and a superior lighting uniformity. System is rated IP66. Performance shall be tested per LM-63, LM-79 and TM-15 (IESNA) certifying its photometric performance. 0% uplight and U0 per IESNA TM-15.

**LE2 TYPE II** Asymmetrical Distribution

**LE3 TYPE III** Asymmetrical Distribution

#### Heat Sink

Built-in the housing, the innovative high efficacy heat sink chimney design ensures superior cooling by natural convection air flow pattern always close to LEDs and driver optimizing their efficiency and life. Product does not use any cooling device with moving parts (only passive cooling). Entire luminaire is rated for operation in ambient temperature of -40°C / -40°F up to +40°C / +104°F.

#### Driver

**For 25W and 35W:** High power factor of >95%. Electronic driver, operating range 50/60 Hz. Auto-adjusting universal voltage input from 120 to 277 VAC rated for both application line to line or line to neutral, Class II, THD of 12% max.

**For 54W:** High power factor of 95%. Electronic driver, operating range 50/60 Hz. Auto-adjusting universal voltage input from 120 to 277 VAC rated for both application line to line or line to neutral, Class II, THD of 20% max.

The current supplying the LEDs will be reduced by the driver if the driver experiences internal overheating as a protection to the LEDs and the electrical components. Output is protected from short circuits, voltage overload and current overload. Automatic recovery after correction. Standard built-in driver surge protection of 2.5kV (min).

#### Vibration Resistance

The SVS meets the ANSI C136.31, American National Standard for Roadway Luminaire Vibration specifications for Bridge/overpass applications. (Tested for 3G over 100 000 cycles by an independent lab).

#### Integrated Features

**RCD:** (standard): Receptacle with 5 pins enabling dimming and additional functionality (to be determined), can be used with a twist lock node or photoelectric cell or a shorting cap.

**DMG:** Dimmable driver 0-10V.

**SP1:** Surge protection device tested in accordance with ANSI/IEEE C62.45 per ANSI/IEEE C62.41.2 Scenario I Category C High Exposure 10kV/10kA waveforms for Line-Ground, Line-Neutral and Neutral-Ground, and in accordance with DOE MSSLC Model Specification for LED roadway luminaires Appendix D Electrical Immunity High test level 10kV/10kA.

*Please note that these integrated features always come with MiniView luminaire.*

#### Luminaire Options

**RCD7:** (optional): Receptacle with 7 pins enabling dimming and additional functionality (to be determined), can be used with a twist lock node or photoelectric cell or a shorting cap.

**API:** Factory Installed NEMA label, ANSI C136.15 compliant

**HS:** House side shield

**PH8\*:** Photoelectric cell

**PHXL\*:** Photoelectric cell, extended life

**PH9\*:** Shorting cap

*\* Luminaire option RCD or RCD7 is required with this accessory.*

#### Luminaire Useful Life

Refer to IES files for energy consumption and delivered lumens for each option. Based on ISTMT thermal testing in accordance with UL1598 and UL8750, System Reliability Tool, Advance data and LM-80/TM-21 data, expected to reach 100,000+ hours with >L70 lumen maintenance @ 40°C. Luminaire Useful Life accounts for LED lumen maintenance AND all of these additional factors including: LED life, driver life, PCB substrate, solder joints, on/off cycles, burning hours, and corrosion.

#### Wiring

The connection of the luminaire is done using a terminal block connector 600V, 85A for use with #2-14 AWG. wires from the primary circuit, located inside the housing.

#### Hardware

All exposed screws shall be zinc with Ceramic primer-seal base coat to reduce seizing of the parts. All seals and sealing devices are made and/or lined with EPDM and/or silicone and/or rubber.

# SVS MiniView LED (small)

## Roadway

### Specifications (continued)

#### Finish

Color to be medium grey (GY3) and in accordance with the AAMA 2603 standard. Application of a polyester powder coat paint (4 mils/100 microns) with  $\pm$  1 mils/24 microns of tolerance. The Thermosetting resins provides a discoloration resistant finish in accordance with the ASTM-D2244 standard, as well as luster retention in keeping with the ASTM-D523 standard and humidity proof in accordance with the ASTM-D2247 standard.

The surface treatment achieves a minimum of 2000 hours for salt spray resistant finish in accordance with testing performed and per ASTM-B117 standard.

#### LED Products Manufacturing Standard

The electronic components sensitive to electrostatic discharge (ESD) such as light emitting diodes (LEDs) are assembled in compliance with IEC61340-5-1 and ANSI/ESD S20.20 standards so as to eliminate ESD events that could decrease the useful life of the product.

#### Certifications and Compliance

cULus Listed for Canada and USA. Luminaire complies with DOE MSSLC Model Specification for LED Roadway Luminaires. MiniView is on the DesignLights Consortium (DLC) Qualified Products List (QPL).

#### Limited Warranty

10-year limited warranty.  
See [signify.com/warranties](http://signify.com/warranties) for details and restrictions.

#### Brackets/Arms

For brackets / arms available with this luminaire, see Lumec 3D for details.

