

**READ AND UNDERSTAND THESE INSTRUCTIONS BEFORE INSTALLING FIXTURE**

This fixture is intended for installation in accordance with the National Electrical Code and local regulations. To assure full compliance with local codes and regulations, check with your local electrical inspector before installation. To prevent electrical shock, turn off electricity at fuse box before proceeding.

**Retain these instructions for maintenance reference.**

**INSTRUCTION SHEET NO.**

**IS:6289**

**1094 Page 1 of 2**

**INSTRUCTIONS FOR ATTACHING SOF-TECH® LOW VOLTAGE TO LYTESPAN® TRACK  
FOR USE WITH LYTESPAN TRACK SYSTEMS ONLY**

**INSTRUCTIONS FOR ATTACHING SOF-TECH® LOW VOLTAGE TO SINGLE CIRCUIT TRACK SYSTEM**

1. Insert into LYTESPAN TRACK (see Fig. 1). LOCKING LEVER must be in same side of track as BEAD.
2. Rotate FITTING 90° clockwise (see Fig. 2).
3. Rotate FITTING until LOCKING LEVER snaps and locks in place (see Fig. 3).
4. To remove: depress LOCKING LEVER, then rotate FITTING 90° counterclockwise.

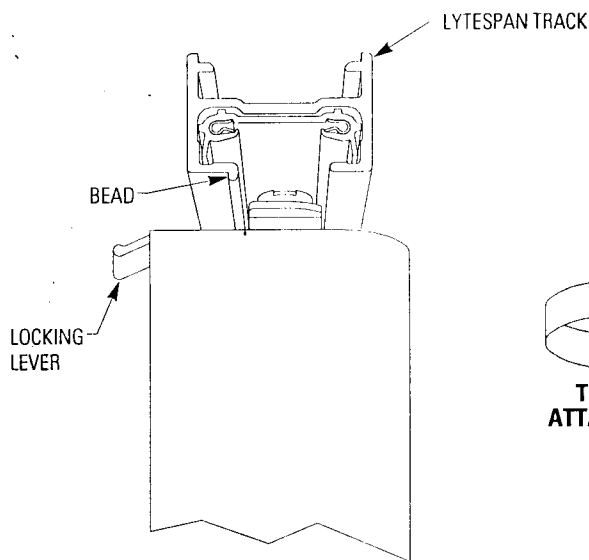

**FIG. 1**

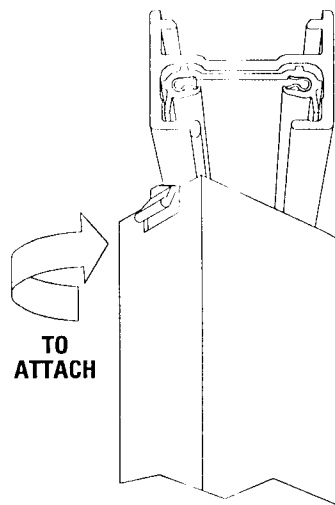

**FIG. 2**

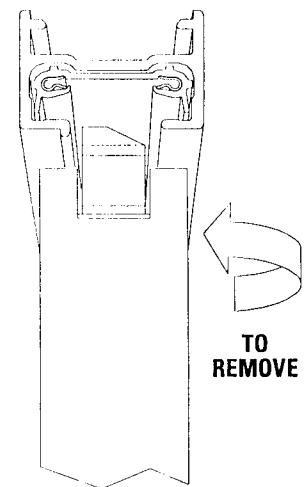

**FIG. 3**

**INSTRUCTIONS FOR CONVERTING SOF-TECH® LOW VOLTAGE  
ATTACHMENT FITTING TO OPERATE ON 2 CIRCUIT TRACK**

(See Fig. 4) BRASS CONTACT can be raised or lowered. Broken line indicates position for 1 circuit track system or lower circuit of 2 circuit track system.

To convert attachment FITTING for upper circuit of 2 circuit track, raised BRASS CONTACT to high position by lifting CONTACT as high as stop permits and CONTACT clicks into place.

SEE BACK FOR LAMPING

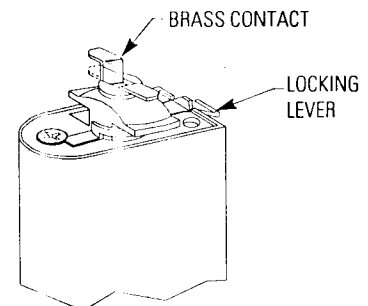

**FIG. 4**

## INSTRUCTIONS FOR LAMPING AND ADJUSTING SOF-TECH® LOW VOLTAGE

1. Check to see that power is OFF when lamping or relamping.
2. Lift the front of the insulating SPADE COVER then take the SPADE TERMINALS and place them under LAMP SCREWS (Fig. 5a); tighten the SCREW until the SPADE TERMINAL is secured.
3. Insert the COVER with LAMP into RING until (3) SPRINGS engage fully with the RING (Fig. 6).
4. To aim fixture, rotate as shown (Fig. 7).

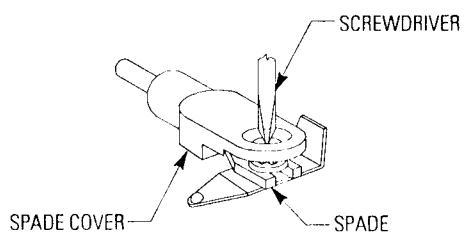

FIG. 5a

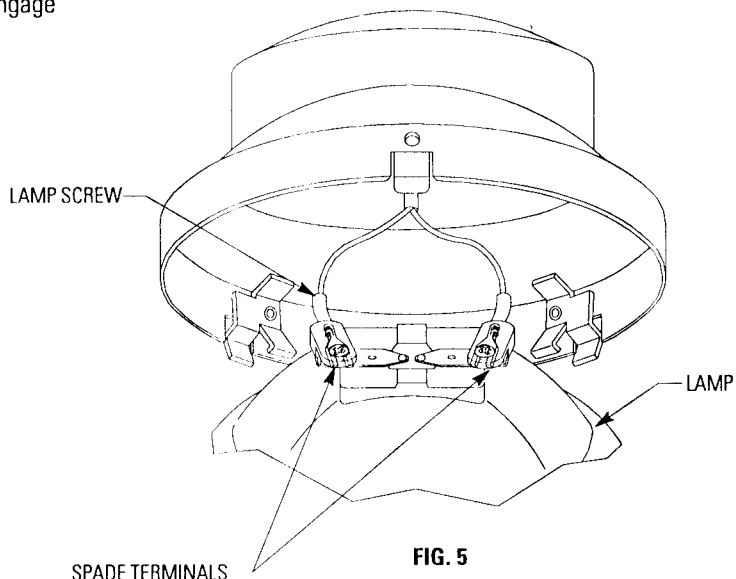

FIG. 5

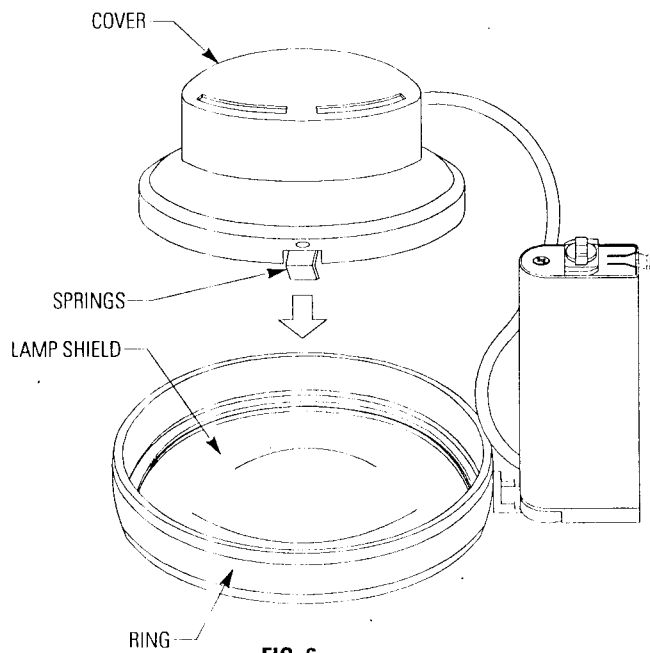

FIG. 6

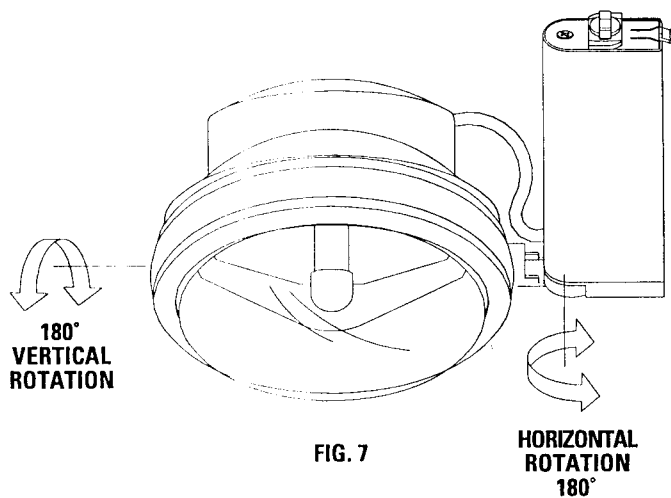

FIG. 7