

ALKCO

Recessed

EvoSeal 2x2

2EVSG up to 8,000 Lumens



Static model



Air return model

The Alkco EvoSeal is designed to meet the needs of modern specialty and healthcare lighting. The opal diffuser softens even high lumen outputs, and the bottom lenses protect the fixture from environmental ingress or abuse. Efficient 90 CRI AccuRender LEDs with optional Tunable White and cyan-enhanced BioUp technologies keep human-centric lighting in mind.

Project: _____
 Location: _____
 Cat.No: _____
 Type: _____
 Lamps: _____ Qty: _____
 Notes: _____

Ordering guide

example: 2ESG55L930-2-250CP-R-UNV-DIM-BAC

Width	Family	Ceiling Type	Lumens (nominal delivered)	Color	Length	Bottom Lens	Center Diffuser	Voltage	Driver	Options
2	ES	G		-	2	-	-	-	-	
2 2'	ES EvoSeal	G Grid	Standard efficacy 30L 3000 35L 3500 40L 4000 45L 4500 50L 5000 55L 5500 60L 6000 65L 6500 70L 7000 80L 8000	930 90 CRI, 3000K 935 90 CRI, 3500K 940 90 CRI, 4000K 950 90 CRI, 5000K	2 2'	125CA 0.125" Clear Acrylic 125CP 0.125" Clear Polycarbonate 187CP 0.187" Clear Polycarbonate 250CP 0.250" Clear Polycarbonate	D Diffuse (opal) DS Diffuse smooth (opal) R Diffuse round ribbed (opal) RS Diffuse round smooth (opal)	UNV Universal Voltage, 120-277 volt 347 347V	DIM ¹ SDIM Dimming Step dimming to 40% input power LDE Lutron LDE5, 1% dimming DALI DALI	F1 3/8" flex, 3 wire 18 gauge 6' F2 3/8" flex, 4 wire 18 gauge 6' F1/D ⁷ 3/8" twin flex, 3 wire 18 gauge 6' for dimmable luminaires. F2/SW ⁷ 3/8" single flex, 5 wire 18 gauge 6' for dimmable luminaires. F2/GW ⁷ 3/8" single flex, 6 wire 18 gauge 6' for dimmable and emergency luminaires Fusing, fast blow. GLR Fuse (for 347V only) SWF UL924 listed sensor bypass relay, factory installed between driver & sensor. Only ordered with an Interact integral sensing option ER100 ^{5,6} UL924 listed sensor bypass relay, factory installed between driver & sensor for 347/480 Power Sense (Interact Pro compatible) ER100/HVPS ^{5,6} UL924 listed sensor bypass relay, factory installed between driver & sensor for 347/480 Power Interrupt (Interact Pro Compatible) ER100/HVPI ^{5,6} UL924 listed Bodine GTD factory installed on driver input. Not available with 347V GTD/E ⁵ UL924 listed Bodine GTD installed between driver & sensor. Not available with 347V GTD/SNSR ^{5,6} Quick driver disconnect DSC Meets the requirements of the Buy American Act of 1933 (BAA) BAC ⁰ Remote Mount Interact Pro scalable sensor with integral daylight & occupancy sensing, advanced grouping with dwell time SWZCS/RM ^{2,3,8} Remote Mount Integral sensor, daylighting and occupancy, advanced grouping with dwell time SWZDT/RM ^{2,8} Interact Pro RF sensor, enables wireless connected lighting control RADIO/RM ^{2,8} Remote Mount Interact Office advanced wireless sensor bundle, integral SC1500 w/IoT capabilities for enterprise scale projects IAOSB/RM ^{2,3,8} Bodine 10W selftesting battery pack BSL10LST Bodine 6W selftesting battery pack BSL6LST

- Integral controls options dimmable to 5% via wireless all switch. Non-controls are 0-10v dimmable to 1%.
- Specify only with -DIM driver option
- Must order IRT9015 Interact commissioning remote with each system order.
- CRM includes side cover with top access plate and additional end cover. 7/8" gap between fixtures.
- Must be installed in conjunction with a UL1008 device.
- Must be ordered with an integral controls option.
- Flex not available with sensors.
- Remote mount sensor ships with the fixture for field installation, intended for mounting remotely in the ceiling next to the fixture
- Sensor is UL damp location listed only
- Failure to properly select the "BAC" suffix could result in you receiving product that is not BAA compliant product with no recourse for an RMA or refund. This BAC designation hereunder does not address (i) the applicability of, or availability of a waiver under, the Trade Agreements Act, or (ii) the "Buy America" domestic content requirements imposed on states, localities, and other non-federal entities as a condition of receiving funds administered by the Department of Transportation or other federal agencies.
- Consult Signify to confirm whether specific accessories are BAA-compliant.

Accessories¹¹ (order separately)

- FMA22 - 2'x2' "F" mounting frame for NEMA "F" mounting

SWZCS accessories¹¹ (order separately)

- IRT9015 - handheld remote for grouping and configuration (at least one remote required for any SWZCS installation).

General Notes

- All options factory installed.
- All accessories are field installed.
- Many luminaire components, such as reflectors, refractors, lenses, sockets, lamp holders, and LEDs are made from various types of plastics which can be adversely affected by airborne contaminants. If sulfur based chemicals, petroleum based products, cleaning solutions, or other contaminants are expected in the intended area of use, consult factory for compatibility.

2EVSG EvoSeal recessed 2x2

up to 8,000 lumens

Ordering guide – DALI Controls (Tunable White and BioUp Cyan Enhanced) example: 2ESG35LBIO-2-125CA-D-UNV-DIM-RADIO/RM

Width	Family	Ceiling Type	Lumens (nominal delivered)	Color	Length	Bottom Lens	Center Diffuser	Voltage	Driver	Options
2	ES	G		-	2 -	-	-	UNV -	-	
2 2'	ES EvoSeal	G Grid	30L 3000 35L 3500 40L 4000 45L 4500 Note: BIO not available on 45L lumen output	9TW 90CRI, 2700K thru 6500K tunable white BIO BioUp Cyan Enhanced Tunable White Notes: BIO not available on 45L lumen output. Tunable White and BioUp must always have a sensor SWZCS/RM or Radio/RM	2 2'	125CA 0.125" Clear Acrylic 125CP 0.125" Clear Polycarbonate 187CP 0.187" Clear Polycarbonate 250CP 0.250" Clear Polycarbonate	D Diffuse (opal) DS Diffuse smooth (opal) R Diffuse round ribbed (opal) RS Diffuse round smooth (opal)	UNV Universal Voltage, 120-277 volt	DIM² Dimming	GLR BSL10LST Fusing, fast blow Bodine 10W selftesting battery pack BSL6LST Bodine 6W selftesting battery pack SWZCS/RM^{2,3,8} Remote Mount Interact Pro scalable sensor with integral daylight & occupancy sensing, advanced grouping with dwell time RADIO/RM^{2,8} Remote Mount Interact Pro RF sensor, enables wireless connected lighting control BAC¹⁰ Meets the requirements of theBuy American Act of 1933 (BAA)

2EVSG EvoSeal recessed 2x2

up to 8,000 lumens

Application

- A highly efficient, visually comfortable, architecturally styled recessed LED luminaire designed with a minimalistic strategy to achieve sustainable objectives.
- Low profile configuration, requiring minimal plenum space.
- Soft opal diffuser with large luminous area minimizes apparent brightness and provides high visual comfort perfect for a wide variety of general lighting applications like offices, schools, retail, or healthcare.
- Multiple lumen packages over a wide range to provide significant application flexibility over light levels and/or luminaire spacing.
- Directs a controlled amount of light to the higher angles in the room to balance the brightness of the surfaces and eliminate "cave effect" while creating the impression of a larger, brighter space without glare.
- Excellent color rendering with 90 CRI AccuRender LEDs
- Optional Tunable White and cyan-enhanced BioUp human-centric lighting options
- Designed for use with standard Grid (NEMA "G") or Narrow Grid (NEMA "NFG") ceiling T-bars.
- Drywall or plaster requirements with DFW24 drywall kit (sold separately)

Construction/Finish

- Simplified center basket design under 3" in depth.
 - Steel housing construction.
 - Choice of multiple center diffuser lenses.
 - Choice of clear acrylic or polycarbonate bottom lens to protect against ingress or abuse.
- Luminaire finish is matte white polyester for a high quality, durable finish.
- T-bar grid clips are integral to body.

Electrical

- Integral sensor options for occupancy sensing and/or daylight harvesting are available for additional energy savings with no reduction of life or increase in installation labor.
- Luminaire Efficacies up to 138 LPW
- LED driver is accessible from above.
- Emergency driver is accessible from above. To estimate lumen output in emergency mode, multiply emergency pack wattage by efficacy, then by 1.10. Typical lumen output exceeds 1300lm for EMLED.
- The GTD/E option is used to bypass wall switches and allow luminaire operation on auxiliary power. Generator transfer requires installation in conjunction with a UL1008 listed device.
- The GTD/SNSR option is used to bypass integrated sensor control in the event of utility power loss. Generator transfer requires installation in conjunction with a UL1008 listed device.
- Step dim 100/40% and additional dimming options available.
- 5 year manufacturer's limited warranty. Visit signify.com/warranties for complete warranty information.
- TM-21 predicted L70 lumen maintenance up to 90,000 hours.

Compliance

- cETLus listed to UL and CSA standards, suitable for damp locations.
- IP65 rated for dust and liquid ingress protection from below
- NSF Non-Food Splash Zone rated
- ISO5-8 cleanroom rated
- IK10 rated for polycarbonate lenses

Energy data

Luminaire	Lumens	Input Power	Efficacy
2ESG30L940-4-125CA-D	3128	23	138
2ESG35L940-4-125CA-D	3430	26	132
2ESG40L940-4-125CA-D	4095	30	136
2ESG45L940-4-125CA-D	4436	35	128
2ESG50L940-4-125CA-D	4912	38	128
2ESG55L940-4-125CA-D	5677	42	134
2ESG60L940-4-125CA-D	5833	46	128
2ESG65L940-4-125CA-D	6615	50	132
2ESG70L940-4-125CA-D	7257	55	132
2ESG80L940-4-125CA-D	7919	69	115

Bottom Lens Multipliers		CCT Multipliers	
Lens	Multiplier	Diffuser	Multiplier
125CA	1.000	930	0.950
125CP	0.980	935	0.960
187CP	0.940	940	1.000
250CP	0.930	950	1.000

Dimensions

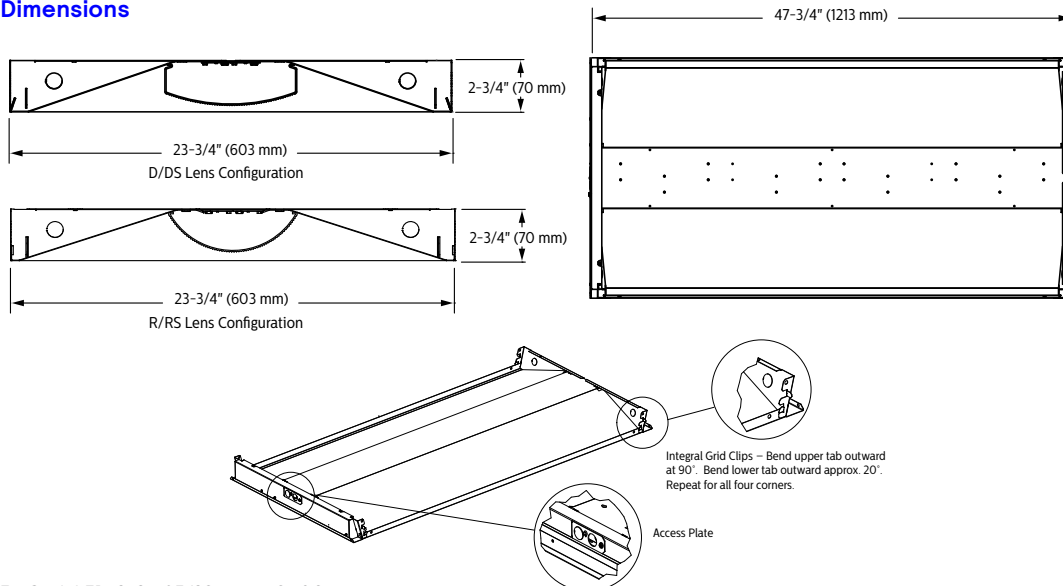

2EVSG EvoSeal recessed 2x2

up to 8,000 lumens

Wireless Controls Options

SpaceWise DT (SWZDT)

- Standalone daylight and occupancy sensing with advanced grouping, wireless mesh networking and dwell time.
- Commissioning via compatible Android phone and Philips Field App
- Dimming via compatible Zigbee wireless wall switch only (see link below for details)
- Register for the commissioning app at <http://registration.componentcloud.philips.com/appregistration/>
- Integral sensing options may not be combined
- For more information including recommended switches, refer to the following: –
SWZDT – www.usa.lighting.philips.com/systems/lighting-systems/spacewise

Emergency Options (ER100)

- Power Sensing (Factory default) – Recommended UL924 option requires unswitched power sense line, absence of voltage on the normal circuit triggers luminaire to 100% output
- Power Interruption Detection (Field option) – Detects AC power interruption >30ms triggers 90 minute emergency mode with luminaire at 100% output

Interact Pro scalable sensor for Foundation, Advanced & Enterprise tiers (SWZCS and an evolution of SpaceWise)

- SWZCS is a connected sensor with integral occupancy and daylight sensing and supports wireless mesh connectivity.
- The sensor works in the Foundation mode (similar to SpaceWise) when configured without a gateway or in an Interact Pro Advanced or Enterprise mode if a compatible gateway is used.
- Interact Pro includes an App, a portal and a broad portfolio of wireless luminaires, lamps and retrofit kits all working on the same system.
- Startup is implemented via Interact Pro App (Android or iPhone) & BlueTooth connectivity. The App provides flexibility to choose between a gateway or non gateway mode for setup.
- Setup with the gateway requires wired internet access to the gateway. It is possible to add a gateway at a later point.
- Prepare project configuration steps remotely and use IRT9015 remote onsite to identify and group devices together.
 - Compatible with:
 - SWS200 wireless scene switch
 - Battery powered IP42 presence sensor OCC sensor IA CM WH 10/1
 - Battery powered IP42 presence & daylight sensor OCC-DL sensor IA CM IP42 WH
 - LCN3110: Battery powered IP65 presence sensor, OCC sensor IA CM IP65WH
 - LCN3120: Battery powered IP65 presence & daylight sensor, OCC-DL sensor IA CM IP65 WH
- For more information on Interact Pro visit: www.interact-lighting.com/interactproscalablesystem

Radio only sensor (RADIO)

- Integral RADIO only sensor simply enables wireless mesh connectivity to the luminaire without any occupancy or daylight sensing.
- Ideal for applications where sensing functionality is managed by other Interact devices and the luminaire only needs to have wireless connectivity.

Interact Pro scalable sensor bundles for Enterprise tier

- IAOSB option in addition to occupancy and daylight sensing supports advanced IoT capabilities such as people estimation analysis, desk level temperature & humidity sensing, noise classification, and BLE beacon.
- Compatible with SWS200 wireless scene switch and Interact Ready wireless battery powered sensors.
- Use Interact software and insights to increase building efficiency, achieve building wide integration and optimize space through occupancy analytics.
- Requires compatible Gateway and internet connectivity for commissioning.
- For more information, visit: www.interact-lighting.com/office or www.usa.lighting.philips.com/systems/system-areas/offices

Wired Controls Options

Interact Office Wired (PoE), Static White & Tunable White

- PoE based IoT connected lighting solution for large enterprises that span across multiple floors, buildings and require multiple gateways.
- Use Interact Office software and insights to increase building efficiency, achieve building wide integration and optimize space through occupancy analytics.
- Human centric lighting through tunable white technology – Dynamic behaviors via scheduled lighting recipes mimicking daylight patterns or supporting biorhythms.
- IAOSB option in addition to occupancy and daylight sensing supports advanced IoT capabilities such as people estimation analysis, desk level temperature & humidity sensing, noise classification, and BLE beacon.
- PoE lighting controller is accessible from below.

- Integral sensor option for occupancy sensing (PIR) and/or daylight harvesting available for additional energy savings.
- Optional integral emergency controller and battery pack provides 600lm nominal output. Test switch and indicator light mounted on side of chassis on one end.
- Emergency battery has a 3 month pre-installed shelf life, and must be stored and installed in environments of 20C to 30C (-4F to 86F) ambient, and 45-85% relative humidity.
- For more information on Interact Office Wired, visit: www.interact-lighting.com/office or www.usa.lighting.philips.com/systems/system-areas/offices

Tunable White with DALI

- Signify tunable white solutions are designed to help maximize the influence of lighting on your daily life.
- Dynamic behaviors via scheduled lighting recipes mimicking daylight patterns or supporting biorhythms.
- Scene setting via lighting pre-sets based on various combinations of lighting color temperature and intensity.

www.usa.lighting.philips.com/products/product-highlights/tunable-white-technology

2EVSG EvoSeal recessed 2x2

up to 8,000 lumens

	Interact		
	Standalone	Option 1	Option 2
Dimming, grouping, and zoning	✓	✓	✓
Bluetooth and ZigBee enabled	✓	✓	✓
Motion sensing and daylight harvesting	✓	✓	✓
Integration with 0-10V and phase dimming fixtures	✓	✓	✓
Code compliance	✓	✓	✓
Granular dimming and dwell time	✓	✓	✓
New Correlated color temperature (CCT) tuning by switch	✓	✓	✓
New Support for sensor-based Tunable White luminaires	✓	✓	✓
Energy reporting and monitoring		✓	✓
Scheduling		✓	✓
Demand response		✓	✓
BMS integration (BACnet)			✓
Floor plan visualization			✓
IoT sensors for wellness			✓
IoT Apps for productivity			✓

Currently supported maximum system size

To be able to design the lighting system correctly for the customer, it is important to know the prime characteristics of the system, its possibilities and limitations.

System level	
Total number of gateways	Unlimited
Total number of devices	200 per network
• luminaires with integrated sensors	150
• smart TLEDs	150
• zones + groups	64
Total number of ZGP devices (sensors and switches)	50
• sensors	30
• switches	50
Group level	
Recommended number of lights	40 (maximum 150)
Number of ZGP devices	5
Number of scenes	16

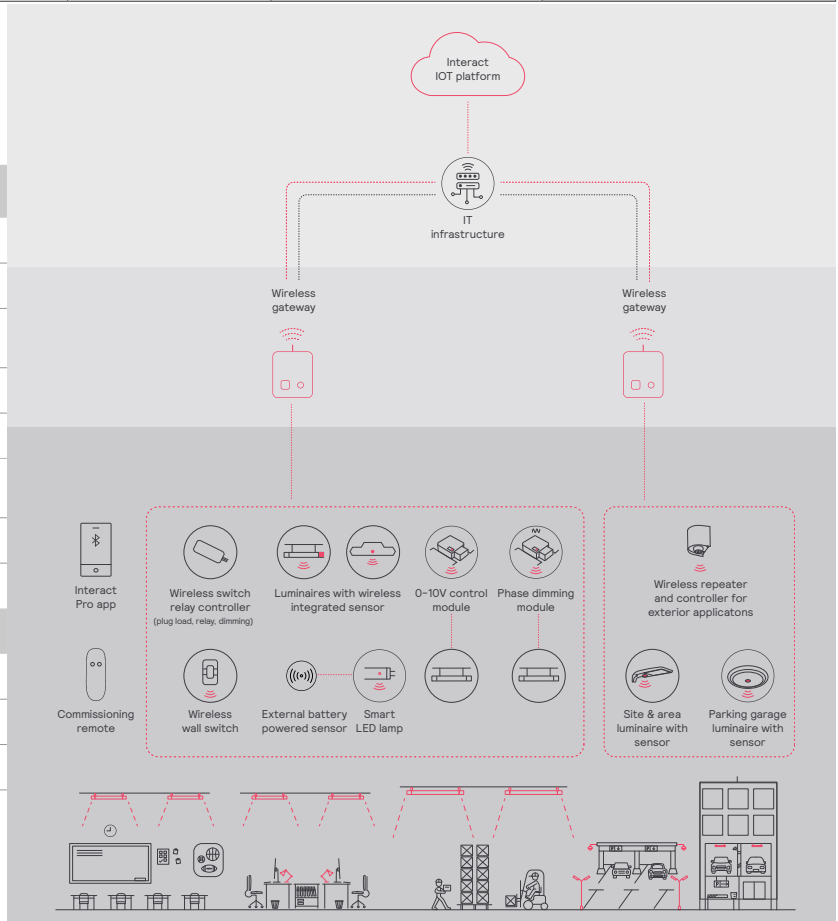

2EVG EvoSeal recessed 2x2

up to 8,000 lumens



© 2022 Signify Holding. All rights reserved. The information provided herein is subject to change, without notice. Signify does not give any representation or warranty as to the accuracy or completeness of the information included herein and shall not be liable for any action in reliance thereon. The information presented in this document is not intended as any commercial offer and does not form part of any quotation or contract, unless otherwise agreed by Signify.

Signify North America Corporation
400 Crossing Blvd, Suite 600
Bridgewater, NJ 08807
Telephone 855-486-2216

Signify Canada Ltd.
281 Hillmount Road,
Markham, ON, Canada L6C 2S3
Telephone 800-668-9008

All trademarks are owned by Signify Holding or their respective owners.