

CHLORIDE

by @ignify

Exit/Emergency

F100 series

Industrial emergency unit, 6V



Project: _____

Location: _____

Cat.No: _____

Type: _____

Lamps: _____ Qty: _____

Notes: _____

Chloride F100 Series is a heavy duty industrial 6V emergency unit ideal for use in industrial locations where a high capacity unit is required and remote fixture capability is desired. F100 Series meets the Buy American requirements.

Ordering guide

Example: F1002H7FBIC

Model	No. of Heads	Lamp Head Type	Model Designator	Options	Accessories (ordered separately)
F100					
F100 6V 87W Unit	2 Two Heads Blank No Heads	H7FB 12V MR16 7W LED, black finish (equivalent to 35W incandescent) M7FB 12V MR16 7W black finish (equivalent to 35W incandescent)	IC Self-Diagnostic ICT Self-Diagnostics with Self-Testing ICTA Self-Diagnostics with Audible Self-Testing	TD Time Delay ² EX Special Input Transformer (specify voltage & frequency) ¹	PVS Polycarbonate Vandal Shield WG9 Wire Guard MBF Mounting Plate for Side Stud ICIR Infra-Red Remote Tester

1. Some option combinations may impact UL Listing.
2. Time delay is 15 minutes.

codes & standards

- ETL listed to UL 924 Standards.
- NFPA 101, NEC, BOCA, OSHA, and IBC illumination standards.
- F100 with two H7FB or M7FB lamp heads meets NRC requirements for an eight-hour run time.
- 3 year warranty on electronics.
- Battery: 5 years full warranty, 10 years pro-rata

application

- Industrial locations where a high capacity unit is required and where remote fixture capability is desired.
- Remote test option enables unit operation testing up to 20 feet away with an ordinary flashlight or laser pointer.
- F100 meets the Buy American requirements.

construction

- Steel 20 gauge wall mounted housing and 18 gauge hinged cover with hammer tone gray epoxy powder coat finish.
- Heavy duty top mounted handle for easy transport up ladders
- Mounting plate (MBF option) is recommended for mounting

electrical

- 120/277 dual voltage input with surge protection is standard on all models.
- Self-powered models feature the Intelli-Charge circuit where the charging system us microprocessor driven with software embedded diagnostic routine and temperature compensation.
- Self-powered models include brownout protection, AC lockout, low voltage disconnect, AC power indicator, charge status indicator, audible user-interface controls, visual LED system fault indicator and tactile push-to-test switch.

- Additional equipment safety features include reverse battery polarity detection and protection, and reverse utility power detection and protection.
- All self-powered models include an on board IR receiver for use with the optional hand held remote (ICIR).
- Optional self-testing electronics provide a diagnostic/charging platform with optional self-testing mode, which automatically runs a one minute self-test once a month and a 30 minute test on the sixth and twelfth month in accordance with NFPA 101.
- A one minute or 90 minute test may be initiated via the push to test switch on the unit or by activating the appropriate test command on the optional IR test device.

batteries

- Extra long-life, heavy industrial grade, sealed lead calcium battery
- 6 V, 36 ampere hour (AH) minimum capacity

F100 Industrial emergency unit

6V

- Cell design protects against deep discharge and requires no addition of water
- Low specific gravity 1.25 (±.10) reduces corrosion rates and lowers electrode sulphation.
- Expected life up to 20 years.
- Optimum operating range of 65°F (19°C) to 90°F (32°C)**
- Increases or decreases in temperature will affect battery performance and/or capacity. Optimum battery performance realized at 77°F (25°C).

power consumption

- F100 @120VAC, .142A,
- F100 @277VAC, .064A

options

- TD - Time Delay circuit causes the emergency lighting equipment to remain under battery power for a period of 15 minutes after the utility power has been restored.
- EX - The special input transformer option allows for input voltage and frequencies beyond the standard 120/277 VAC 60Hz input.
- IC - All models feature the Intelli-Charge circuit where the charging system is micro-processor driven with software embedded diagnostic routine and temperature compensation.

- ICT - This self-testing option enables a periodic self-test of the equipment where a test routine is established to perform a one minute test once a month with a 30 minute test performed on the 6th and 12th month in accordance with NFPA 101 Equipment readiness are indicated with a visual LED display.
- ICTA - The audible self-testing option enables a periodic self-test of the equipment where a test routine is established to perform a one minute test once a month with a 30 minute test performed on the 6th and 12th month in accordance with NFPA 101 Equipment readiness are indicated with a visual LED display and an audible alarm.

lamp selection

- The H Head features a dual-axis swivel mount and is constructed of high-impact polycarbonate, and is offered in black to complement the unit's gray housing. It utilizes a 12 volt MR16, 7 watt LED lamp.
- The M head is constructed of a deep drawn powder-painted black steel lamp head utilizing a 12 volt MR16, 7 watt LED lamp for maximum performance.

Model	Suggested Lamp Head	AC Input		DC Voltage	Wattage to 87.5 of Rated Voltage++			
		Voltage	Wattage+		1.5 hrs.	2 hrs.	4 hrs.	8 hrs.
F100	H7FB	120/277	45	6	87	65	42	24
F100	M7FB	120/277	45	6	87	65	42	24

+Based on high rate charge after power loss.

++Per NFC specifications.

6V/87W industrial emergency unit

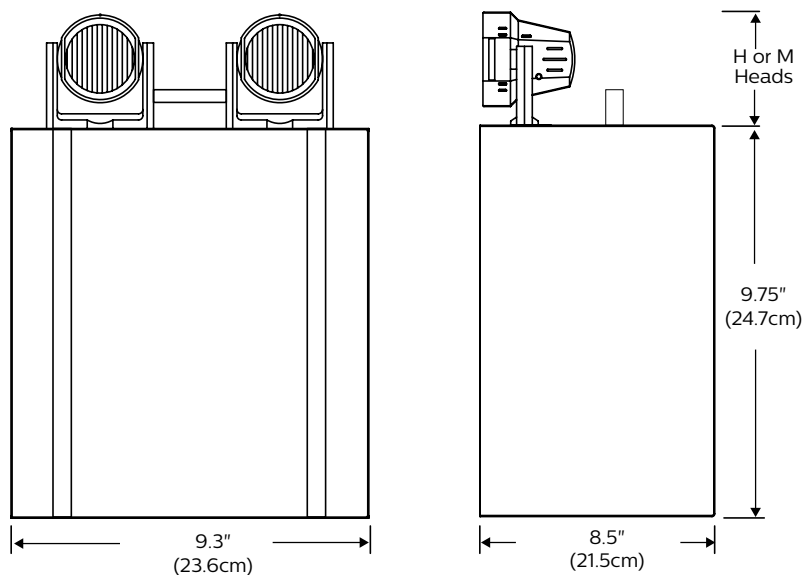

H-Head, LED

H7FB - 12V/7W/LED
3.5" H X 4.6" W



M-Head, LED, Steel

M7FB - 6V/7W
5" H X 3.53" W

